

(CITY'S NAME OF PROJECT)

START DATE: (MONTH 20XX)

COMPLETION DATE: (MONTH 20XX)



OWNER:
CITY AND BOROUGH OF SITKA
100 LINCOLN ST.
747-1804

FUNDED BY (EXAMPLES):

CONTRACTOR:
(CONTACT
COMPANY NAME
###-###-####)

(LAND AND WATER CONSERVATION FUND)
(ALASKA CLEAN WATER FUND)
(RASMUSON FOUNDATION)
(MEN'S/ WOMEN'S SOFTBALL ASSOC.)
(CITY AND BOROUGH OF SITKA)

DESIGNER:
(COMPANY NAME)

NOTES:

ALL ITEMS IN PARENTHESIS' ARE EXAMPLE ITEMS AND WILL CHANGE PER PROJECT.

SIGN DIMENSIONS: 4' X 8' X 1/8"
ALUMINUM PANEL

LETTERS:

TITLE= 2 1/2"

INFORMATION= 1 1/4"

EMBLEM= 2' DIA.



SCALE:
NTS
APPROVED:
RAR
REVISED:
1/18/08

CONSTRUCTION SIGN DETAIL

SECTION#
15.02

DETAIL #
15-1

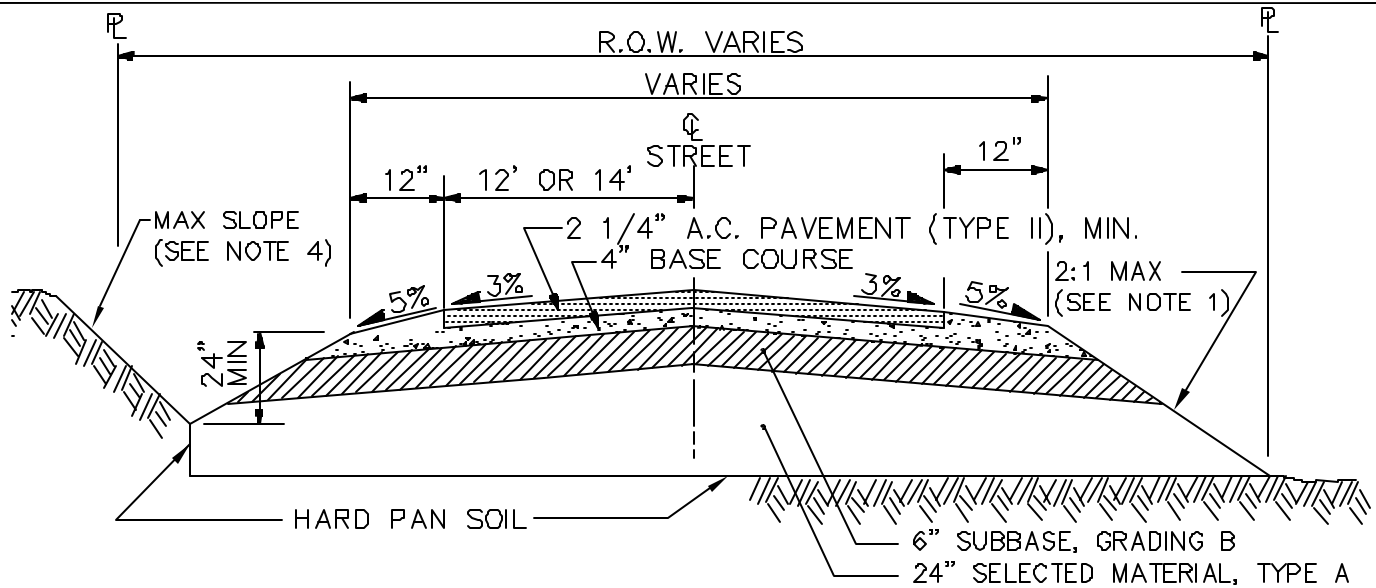

TYPICAL SECTION - 24'/28' STRIP PAVING

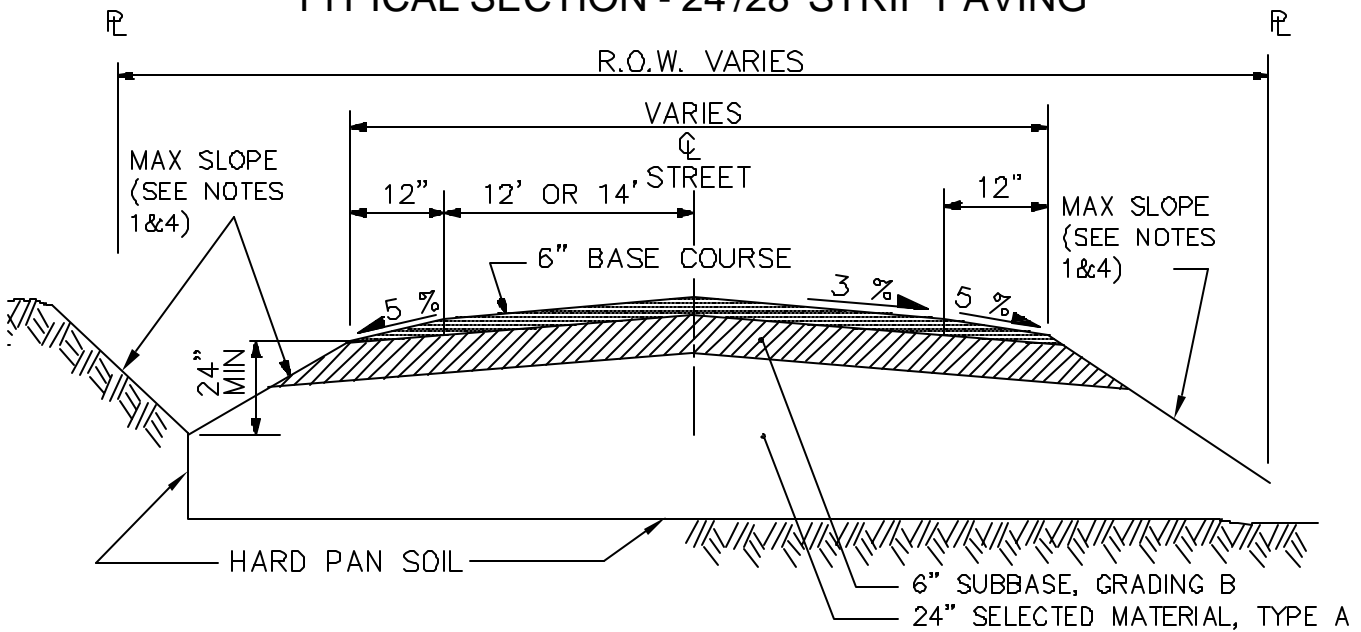

TYPICAL SECTION - 24'/28' GRAVEL STREET

NOTES:

1. MATERIAL TO BE PLACED OR REMOVED AND GRADED IN A NEAT MANNER FROM EXCAVATION LIMITS TO EXISTING ELEVATION AT PROPERTY LINE AS DIRECTED BY THE ENGINEER.
2. EXCAVATE ROAD PRISM MIN. OF 36" OR DEEPER AS REQUIRED TO REACH HARD PAN SOIL
3. UNLESS OTHERWISE APPROVED, THE Q OF STREET WILL BE THE Q OF R.O.W.
4. CUT SLOPES: IN SOIL USE 2:1 MAX., IN ROCK USE 0.5:1 MAX.
5. MINIMUM PAVEMENT THICKNESS MAY BE INCREASED AT ENGINEER'S DESCRETION DEPENDENT UPON VARIABLES SUCH AS TRAFFIC FREQUENCY, WHEEL AND AXLE LOADING, SUBGRADE INTEGRITY, ETC..



SCALE:
NTS
APPROVED:
RAR
REVISED:
11/29/02

**TYPICAL SECTIONS FOR
24'/28' STRIP PAVING
AND GRAVEL STREETS**

SECTION#
20.01
THRU# 20.14
DETAIL #
20-1

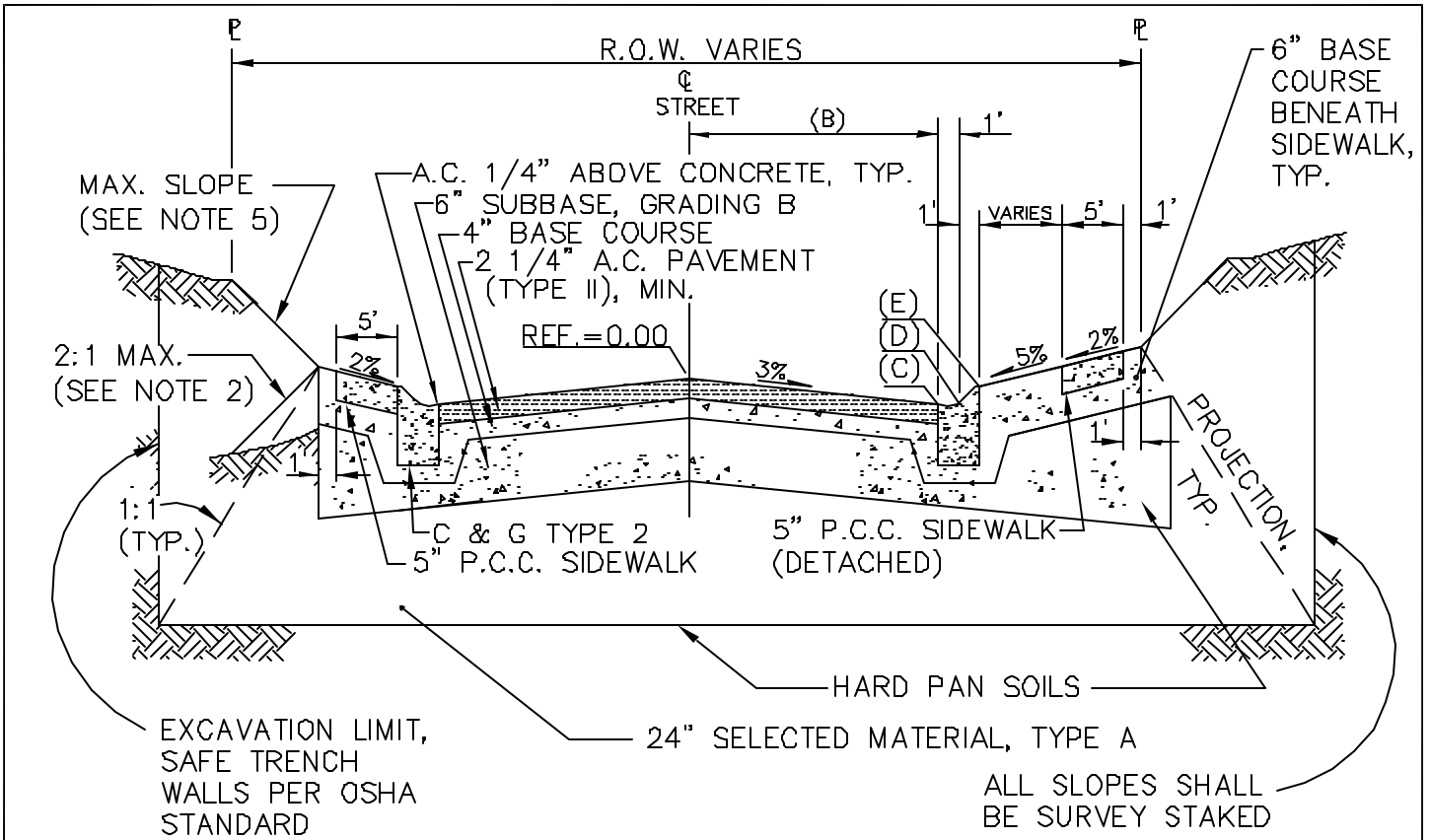

PAVEMENT WIDTH	(B) PAVEMENT	(C) LIP C&G	(D) F.L. C&G	(E) BACK C&G
24'	12'	-0.36	-0.44	-0.19
26'	13'	-0.39	-0.47	-0.22
29'	14.5'	-0.44	-0.52	-0.27
32'	16'	-0.48	-0.56	-0.31
36'	18'	-0.54	-0.62	-0.37

- NOTES:
1. ALL DIMENSIONS AND ELEVATIONS AS SHOWN ON THIS DRAWING ARE TYPICAL BUT MAY VARY IN SPECIFIC INSTANCES AS SHOWN ON PLAN-PROFILE DRAWINGS OR AS DETERMINED BY THE ENGINEER.
 2. MATERIAL TO BE PLACED OR REMOVED AND GRADED IN A NEAT MANNER FROM EXCAVATION LIMITS TO EXISTING ELEVATION AT PROPERTY LINE AS DIRECTED BY THE ENGINEER.
 3. EXCAVATE ROAD PRISM MIN. OF 36", OR DEEPER AS REQ'D TO REACH HARD PAN SOIL.
 4. UNLESS OTHERWISE APPROVED THE ϕ OF STREET WILL BE THE ϕ OF R.O.W.
 5. CUT SLOPES: IN SOIL USE 2:1 MAX., IN ROCK USE 0.5:1 MAX.
 6. MINIMUM PAVEMENT THICKNESS MAY BE INCREASED AT ENGINEER'S DISCRETION DEPENDENT UPON VARIABLES SUCH AS TRAFFIC FREQUENCY, WHEEL AND AXLE LOADING, SUBGRADE INTEGRITY, ETC..



SCALE:
NTS
APPROVED:
RAR
REVISED:
11/29/02

24', 26', 29', 32' AND 36' STREETS

SECTION#
20.01
THRU# 20.14

DETAIL #
20-2

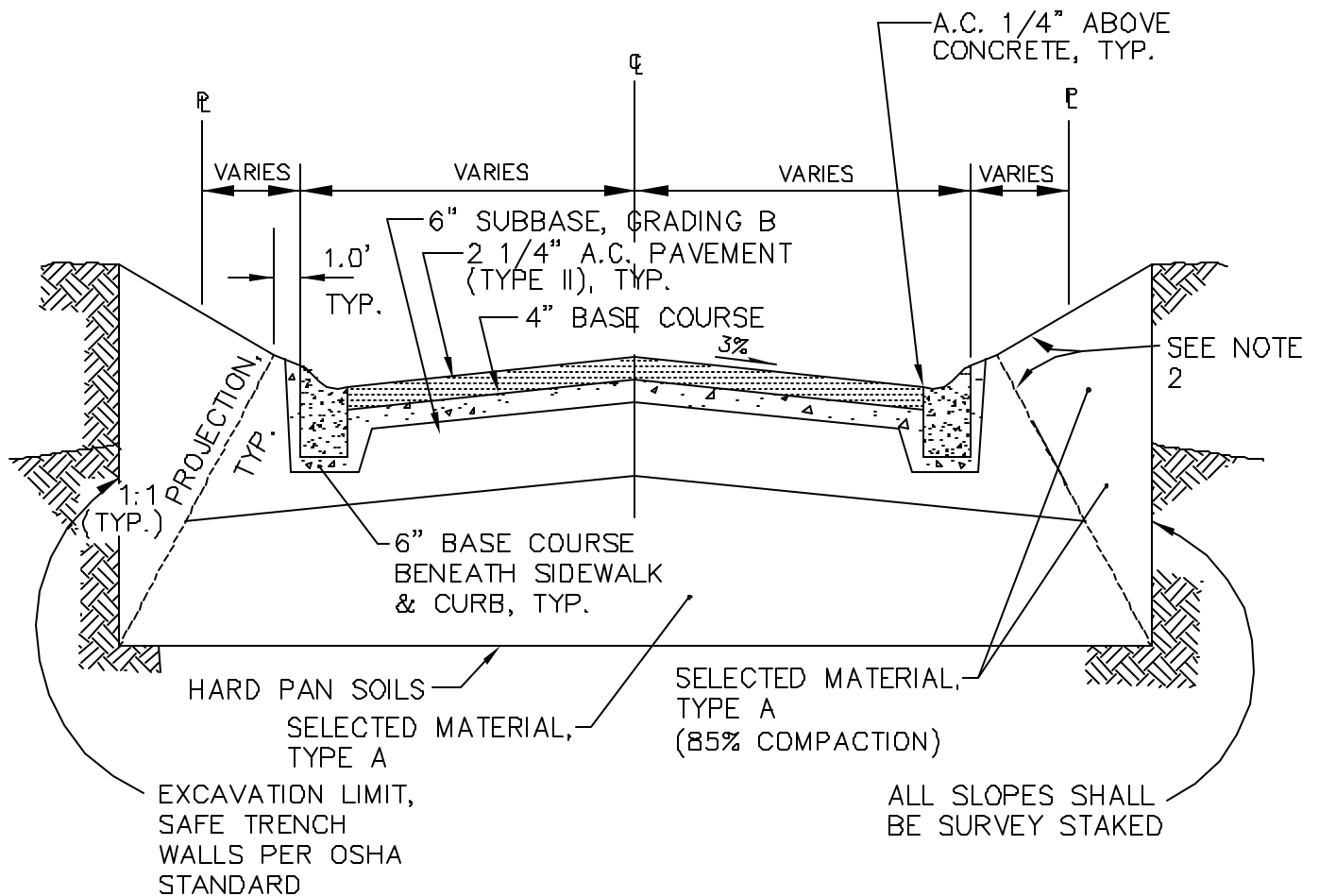

NOTES:

1. ALL DIMENSIONS & ELEVATIONS AS SHOWN ON THIS DRAWING ARE TYPICAL BUT MAY VARY IN SPECIFIC INSTANCES AS SHOWN ON THE PLAN-PROFILE DRAWINGS OR AS DETERMINED BY THE ENGINEER.
2. MATERIAL TO PLACED OR REMOVED & GRADED IN A NEAT MANNER FROM EXCAVATION LIMITS TO EXISTING ELEVATION AT PROPERTY LINE AS DIRECTED BY THE ENGINEER (MAX. 2:1 CUT & FILL SLOPES IN SOIL, MAX. 0.5:1 CUT SLOPE IN ROCK)
3. DEPTH OF EXCAVATION TO BE DETERMINED BY THE ENGINEER.
4. SEE APPLICABLE STANDARD DETAIL FOR SPECIFIC STREET DIMENSIONS.
5. MINIMUM PAVEMENT THICKNESS MAY BE INCREASED AT ENGINEER'S DESCRETION DEPENDENT UPON VARIABLES SUCH AS TRAFFIC FREQUENCY, WHEEL AND AXLE LOADING, SUBGRADE INTEGRITY, ETC..



SCALE:
NTS
APPROVED:
RAR
REVISED:
11/29/02

TYPICAL SECTION DEEP EXCAVATION

SECTION#
20.01
THRU# 20.14

DETAIL #
20-3

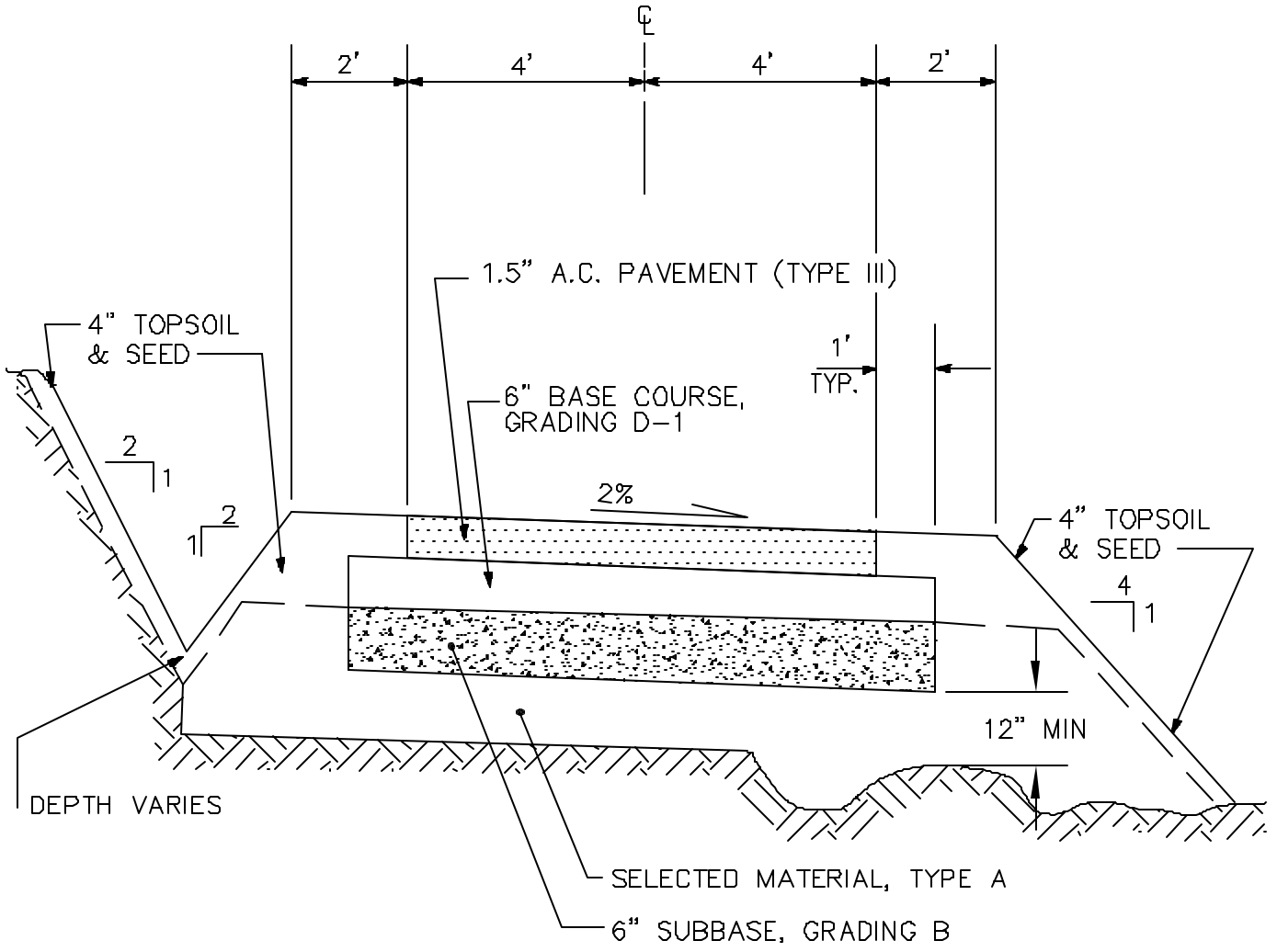

NOTES:

1. DEPTH OF CLASSIFIED FILL OR BACKFILL TO BE DETERMINED BY THE ENGINEER.
2. DEPTH OF DITCH SHALL BE AS NECESSARY FOR POSITIVE DRAINAGE AS DIRECTED BY THE ENGINEER.
3. CROSS CULVERTS SHALL BE PLACED AS DIRECTED BY THE ENGINEER.



SCALE:
NTS
APPROVED:
RAR
REVISED:
11/29/02

TYPICAL BIKE TRAIL

SECTION#
20.01
THRU# 20.14
DETAIL #
20-4

GRADING LIMITS

U.S. STANDARD SIEVE	CUMULATIVE % PASSING BY WEIGHT
1"	100
3/4"	70-100
3/8"	50-80
#4	35-65
#8	20-50
#40	8-30
#200	*0-6

* IN ADDITION TO THE GRADING LIMITS LISTED ABOVE, THE FRACTION OF MATERIAL PASSING THE #200 SIEVE SHALL NOT BE GREATER THAN 75% OF THAT FRACTION PASSING THE #50 SIEVE.

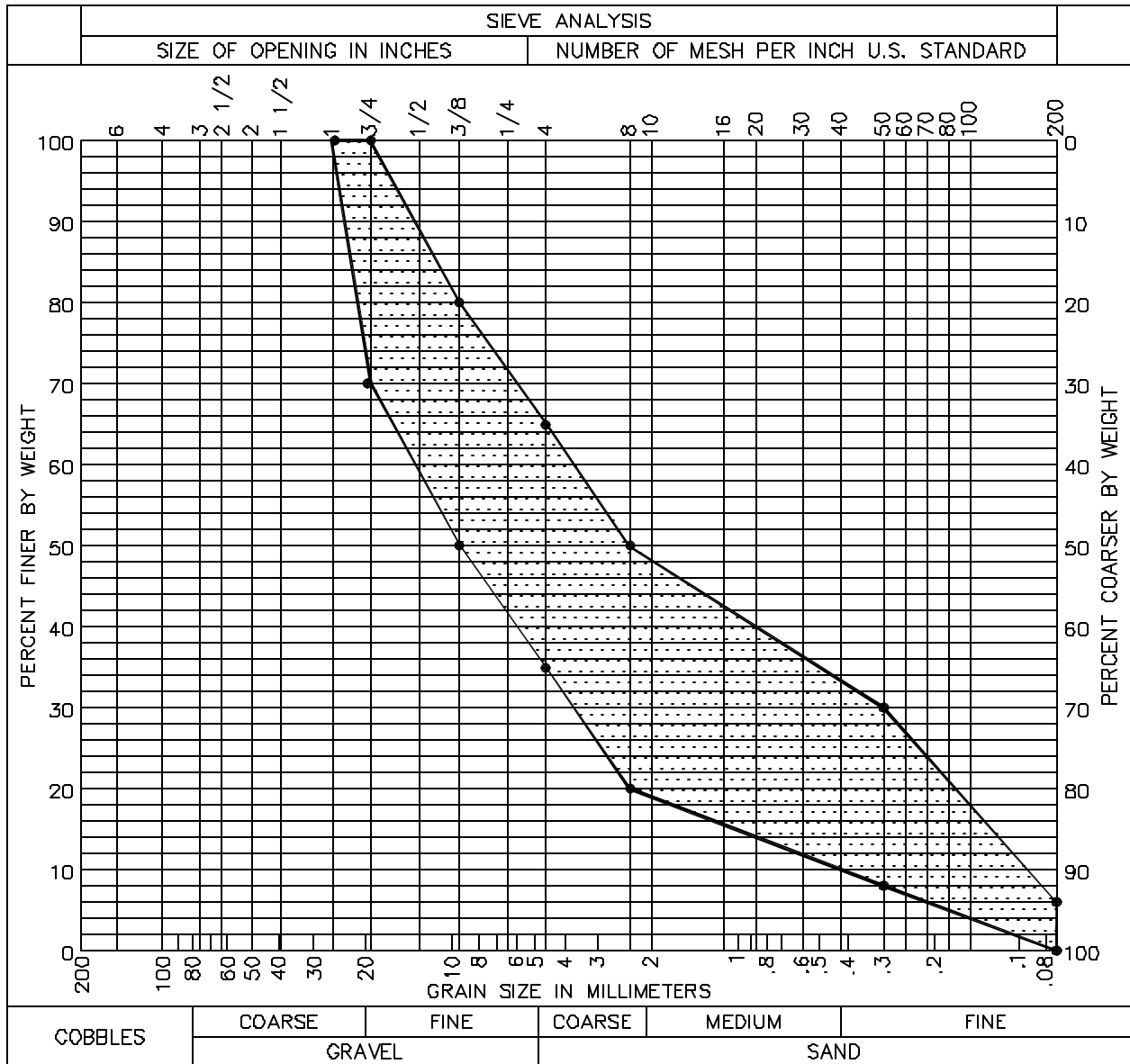

SCALE:
NTS
APPROVED:
RAR
REVISED:
11/29/02

BEDDING MATERIAL AND BASE COURSE, GRADING D-1

SECTION #
20.06

DETAIL #
20-5

GRADING LIMITS

U.S. STANDARD SIEVE	CUMULATIVE % PASSING BY WEIGHT
2"	100
3/4"	60-100
#4	30-65
#10	20-50
#40	10-30
#200	*2-6

* IN ADDITION TO THE GRADING LIMITS LISTED ABOVE, THE FRACTION OF MATERIAL PASSING THE #200 SIEVE SHALL NOT BE GREATER THAN 15% OF THAT FRACTION PASSING THE #4 SIEVE.

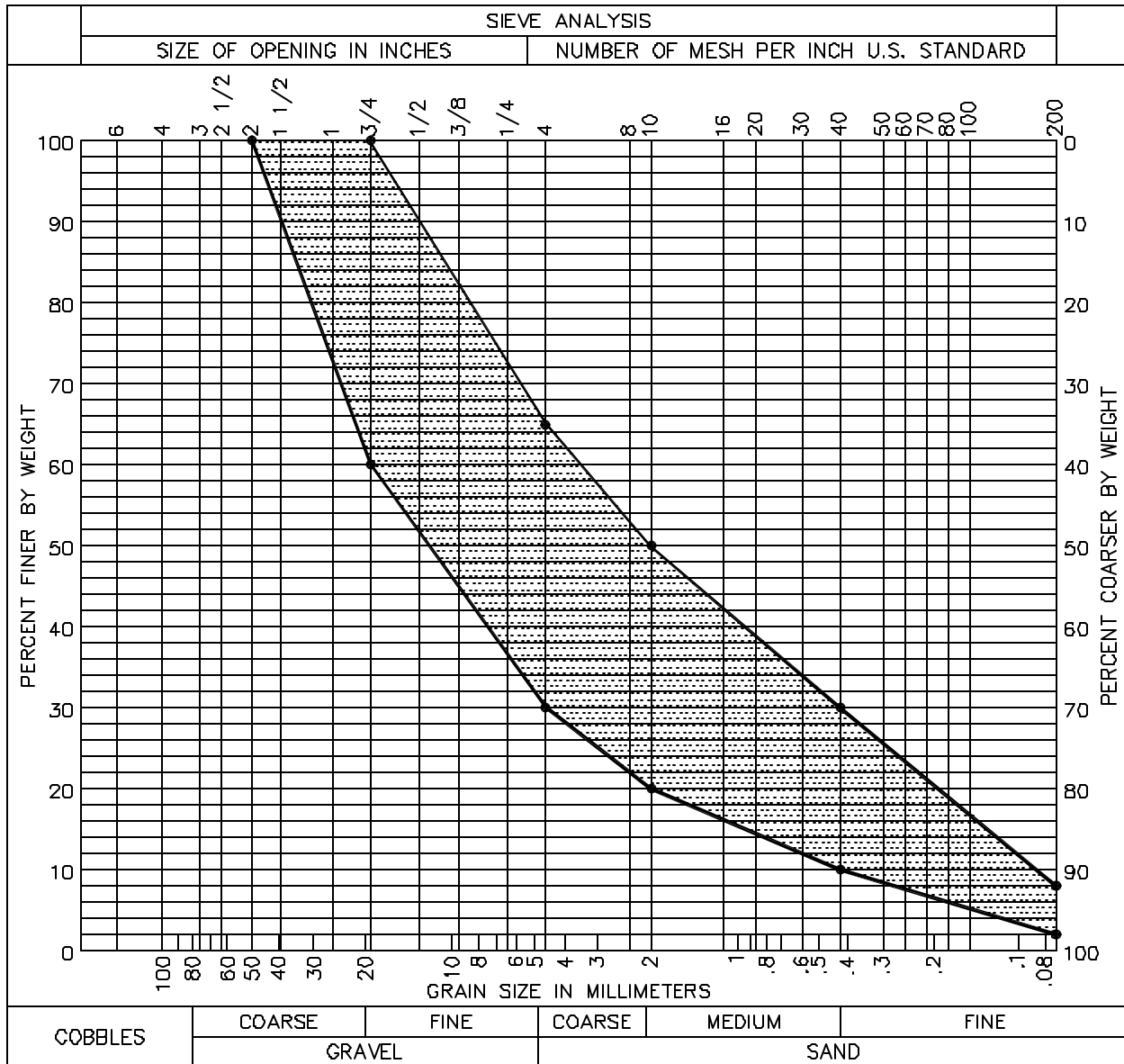

SCALE:
NTS
APPROVED:
RAR
REVISED:
11/29/02

SUBBASE, GRADING B CLASSIFIED FILL & BACKFILL

SECTION #
20.06
DETAIL #
20-6

NEAT LINE PAY LIMITS
(WHEN USED)

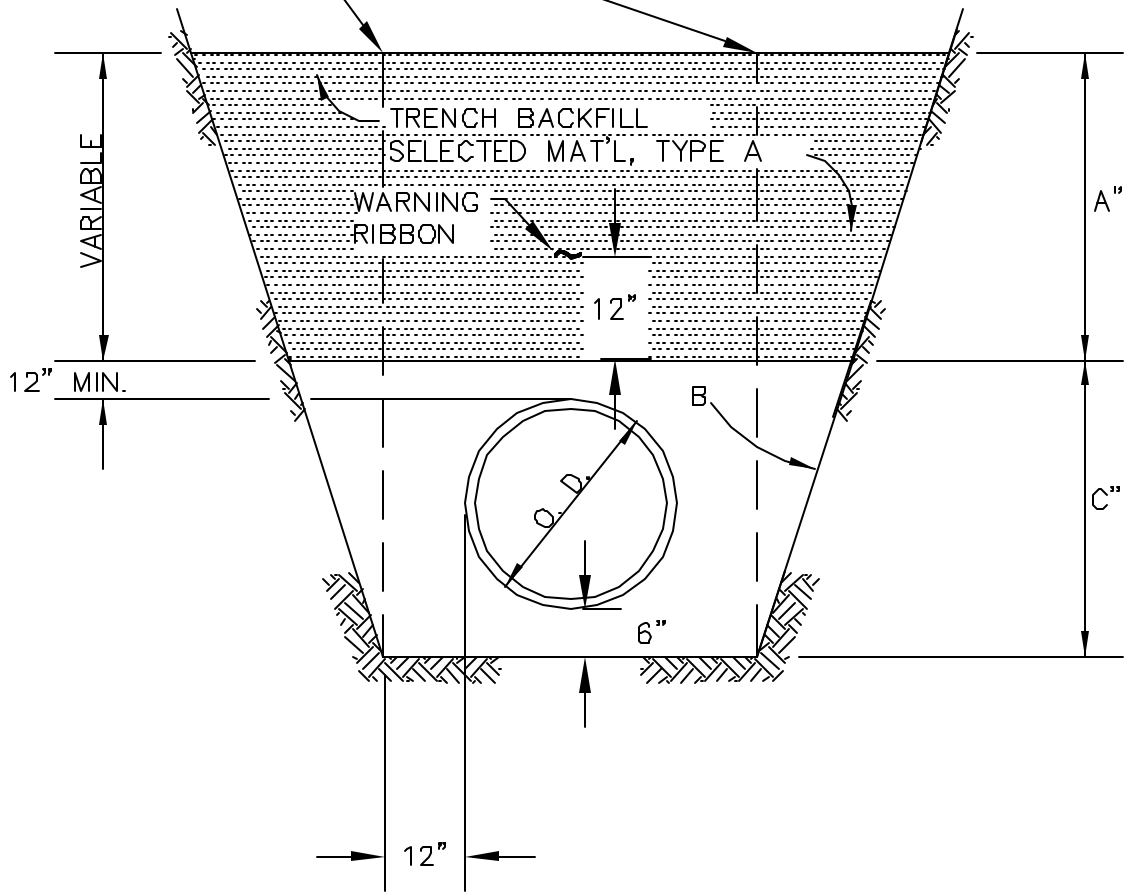

NOTES:

- (A) TRENCH BACKFILL MATERIAL PLACED AND COMPACTED TO DEPTHS AS DETERMINED BY THE ENGINEER.
- (B) TRENCH WALL SLOPES WILL VARY WITH SOIL STRENGTH AND CHARACTER. SLOPES TO CONFORM TO OSHA STANDARDS.
- (C) BEDDING: D-1 FOR WATER AND SEWER MAINS AND SERVICES;
C-1 FOR STORM DRAIN PIPING.



SCALE:
NTS
APPROVED:
RAR
REVISED:
11/29/02

TRENCH BACKFILL

SECTION #
20.07

DETAIL #
20-7

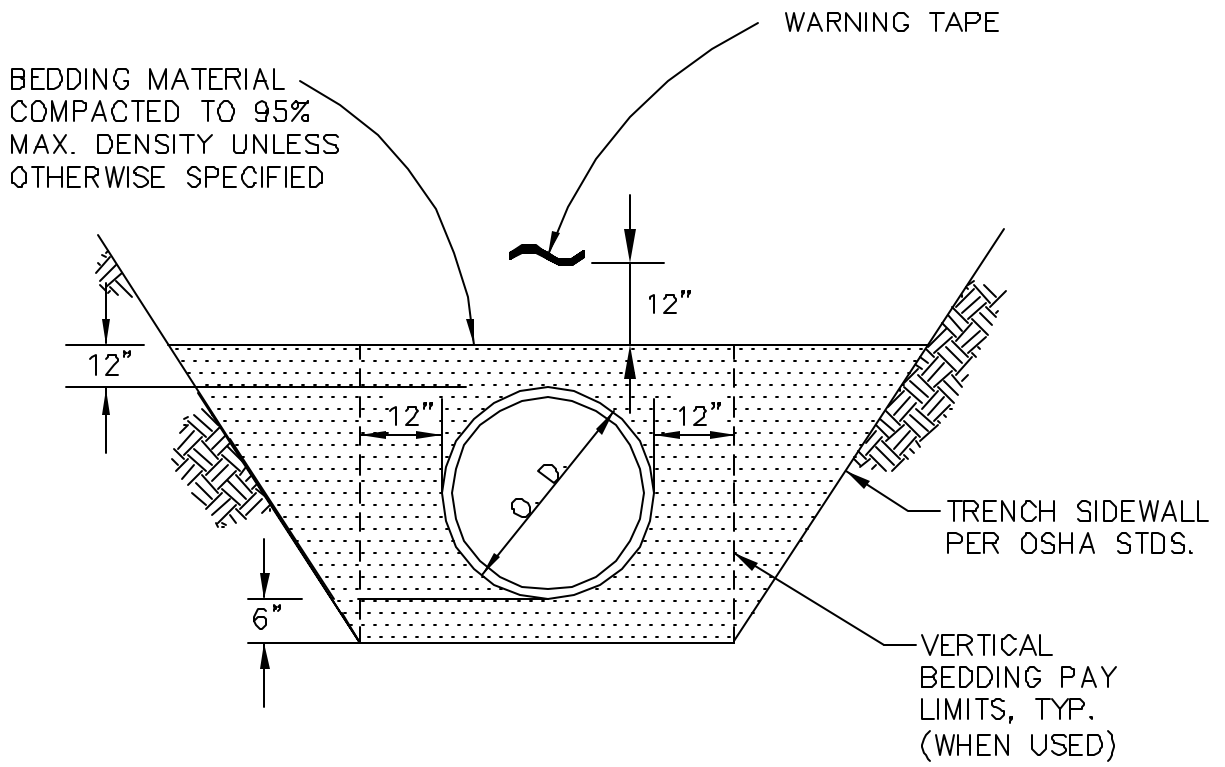

NOTES:

1. TRENCH WALL SLOPE WILL VARY WITH SOIL STRENGTH AND CHARACTER
2. O.D. = OUTSIDE DIAMETER OF PIPE.
3. BEDDING: D-1 FOR WATER AND SEWER MAINS AND SERVICES;
C-1 FOR STORM DRAIN PIPING.



SCALE:
NTS
APPROVED:
RAR
REVISED:
11/29/02

BEDDING

SECTION #
20.07

DETAIL #
20-8

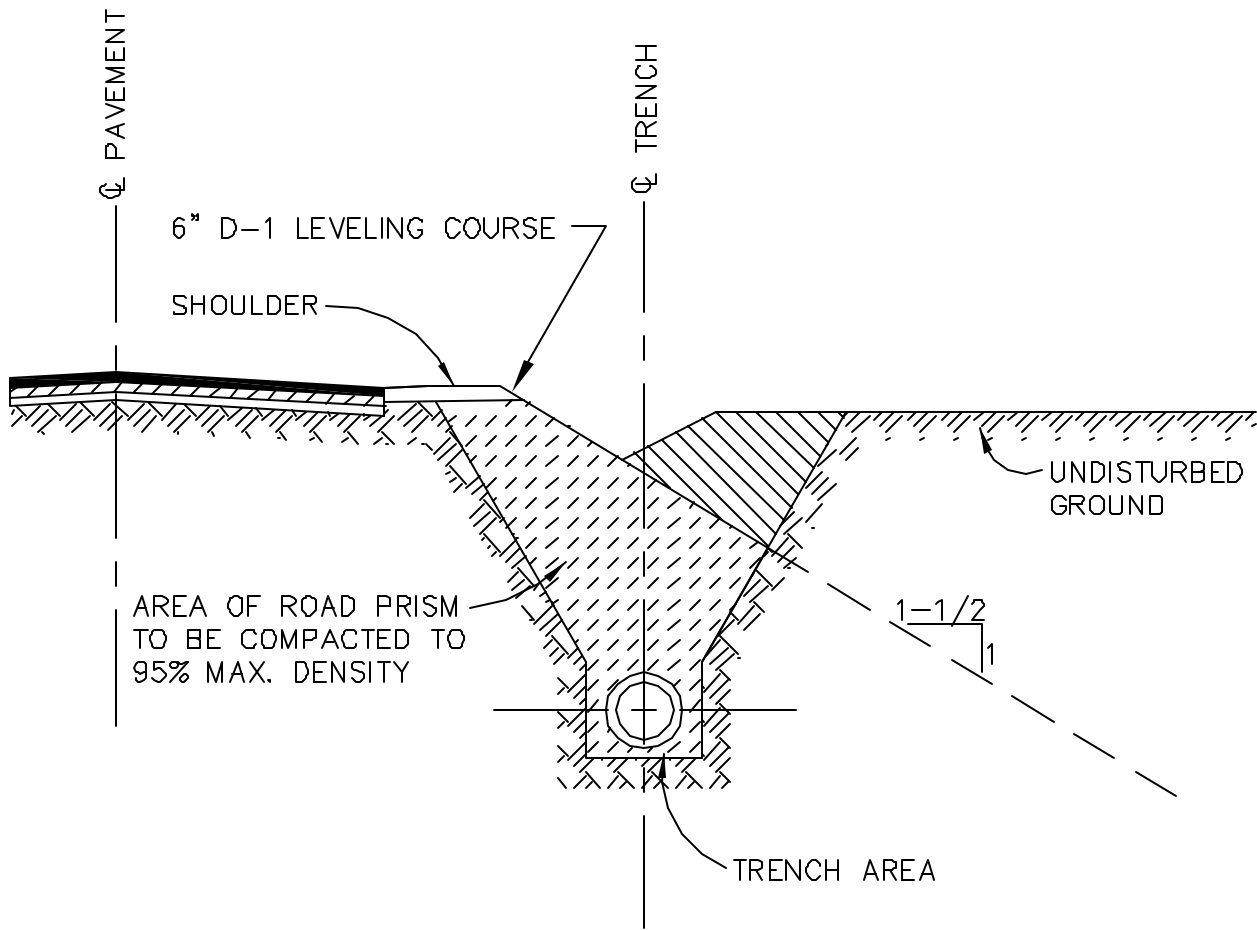

NOTES:

1. ALL MATERIAL THAT IS TO BE BACKFILLED WITHIN THE ABOVE-DESCRIBED AREA TO BE COMPACTED TO 95% MAX DENSITY
2. THIS BACKFILL WILL BE FREE OF ANY EXTENSIVE CLAYS & ORGANIC MATERIALS.
3. THE COMPACTION OF THIS BACKFILL WILL BE ACCOMPLISHED BY MECHANICAL MEANS WITHOUT THE AID OF WATER.
4. THE DITCH LINE WILL BE RESHAPED IN SUCH A MANNER AS TO ALLOW PROPER DRAINAGE & THE SHOULDER OF THE ROAD WILL BE REPLACED AT A UNIFORM SLOPE NOT TO EXCEED 1-1/2 TO 1.



SCALE:
NTS
APPROVED:
RAR
REVISED:
11/29/02

COMPACTION OF BACKFILL WITHIN RIGHT-OF-WAY

SECTION #
20.07

DETAIL #
20-9

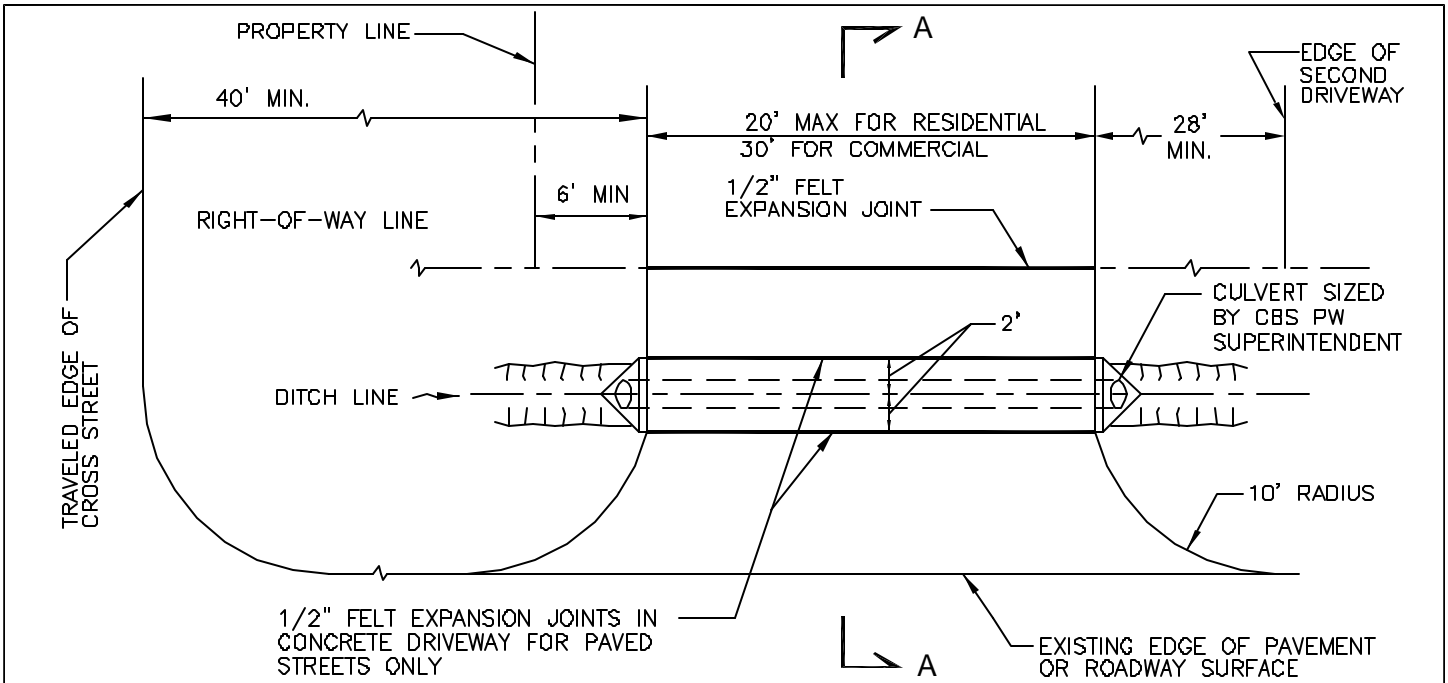

PLAN VIEW

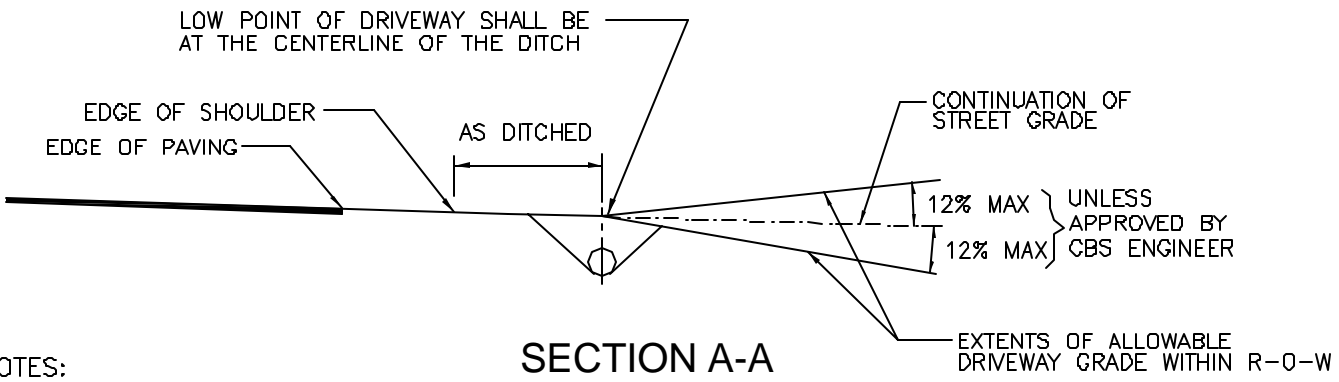

SECTION A-A

NOTES:

1. CULVERT MUST SLOPE TO DRAIN.
2. COMBINED DRIVEWAYS ARE ALLOWED WHEN APPROVED BY THE CBS PLANNING COMMISSION FOR SUBDIVISIONS OR CONDITIONAL USE. COMBINED ZERO LOT LINE PROPERTIES' DRIVEWAYS SHALL NOT EXCEED 32' IN WIDTH.
3. PAVING LIMIT FOR GRAVEL ROADS SHALL BE 2' FROM THE CENTERLINE OF DITCH OR AS APPROVED BY THE ENGINEER.
4. DRIVEWAY SHALL BE GRADED TO DRAIN INTO DITCH.
5. LOCATION AND WIDTH TO BE APPROVED BY THE CBS ON A SITE SPECIFIC BASIS. PLACE A MARKER, AS INDICATED, AT THE CENTER OF THE PROPOSED DRIVEWAY FOR INITIAL INSPECTION BY CBS.
6. SUBBASE MATERIAL AND DEPTH WITHIN THE RIGHT-OF-WAY SHALL CONFORM TO STANDARD DETAIL 20-1.
7. AT CORNER LOTS, DRIVEWAY ENTRANCE MUST BE PLACED ON THE SECONDARY ROADWAY AND NO PORTION OF THE DRIVEWAY SHALL BE PERMITTED WITHIN 25 FEET OF THE PROPERTY CORNER OR INTERSECTION OF RIGHT-OF-WAY LINES.
8. SIGHT DISTANCE PER STANDARD DETAILS 20-11 & 20-12.

	<p>SCALE: NTS APPROVED: RAR REVISED: 11/29/02</p>	<p>DRIVEWAYS FOR STREETS WITHOUT CURB AND GUTTER</p>	<p>SECTION# DETAIL # 20-10</p>
--	---	---	---

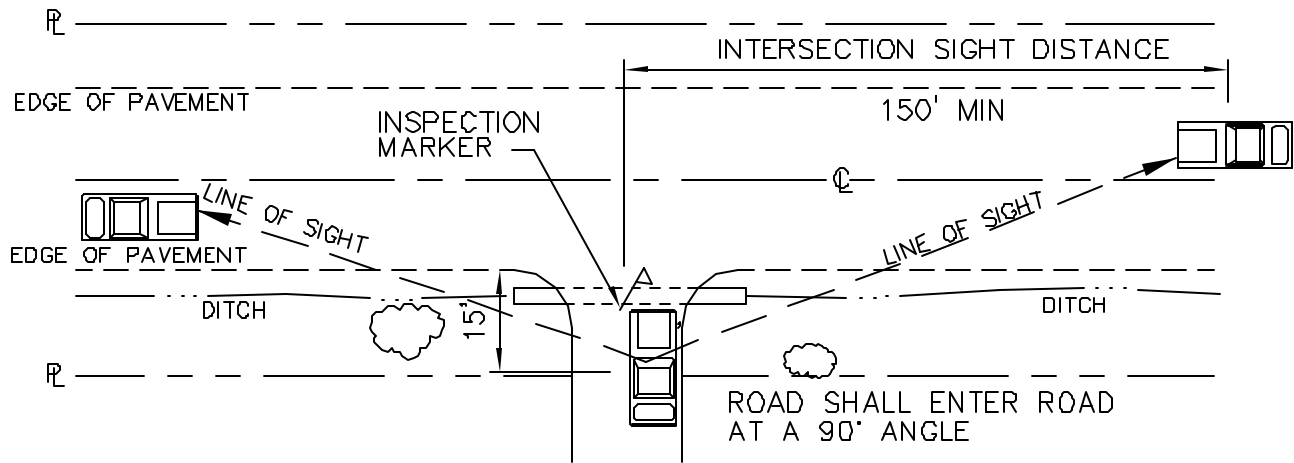

NOTES:

1. SIGHT DISTANCE IS MEASURED 15' FROM THE EDGE OF TRAVEL LANE AT STANDARD EYE HEIGHT OF 3.5'.
2. TREES, SOIL AND OTHER OBSTRUCTIONS WITHIN THE SIGHT DISTANCE TRIANGLE SHALL BE REMOVED OR CLEARED BY THE APPLICANT.
3. LOCATION AND WIDTH TO BE APPROVED BY THE CITY ON A SITE SPECIFIC BASIS. PLACE A MARKER, AS INDICATED, AT THE CENTER OF THE PROPOSED DRIVEWAY FOR INITIAL INSPECTION BY THE CITY.



SCALE:
NTS
APPROVED:
RAR
REVISED:
11/29/02

TYPICAL SIGHT DISTANCE AT INTERSECTIONS

SECTION #

DETAIL #
20-11

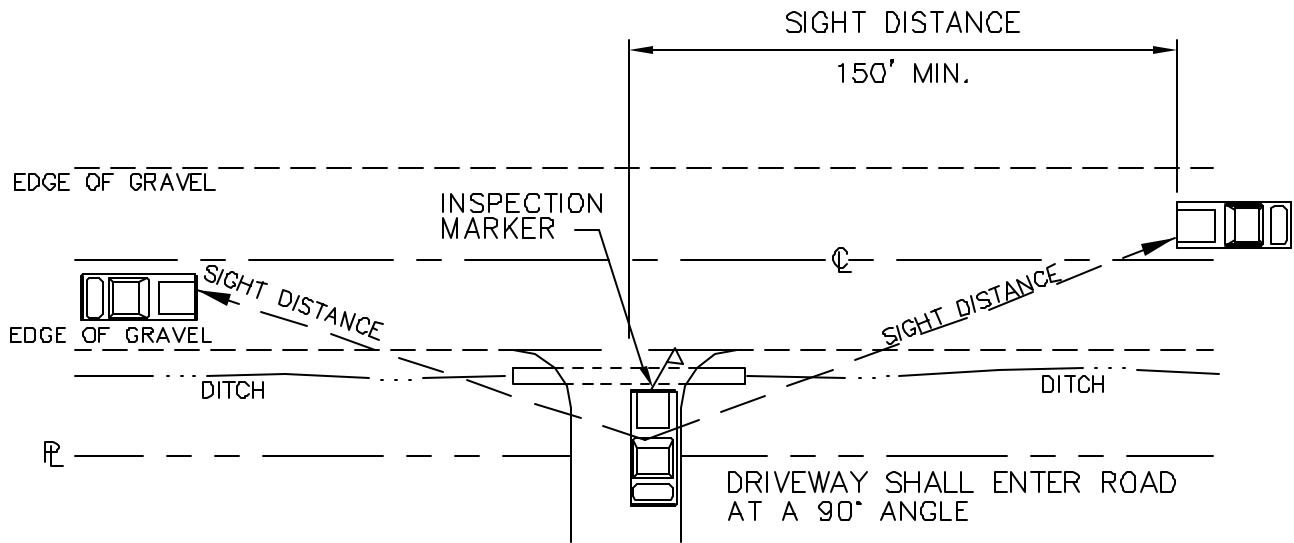

NOTES:

1. SIGHT DISTANCE IS MEASURED 10' FROM THE EDGE OF TRAVEL LANE AT STANDARD EYE HEIGHT OF 3.5'.
2. TREES, SOIL AND OTHER OBSTRUCTIONS WITHIN THE SIGHT DISTANCE TRIANGLE SHALL BE REMOVED OR CLEARED BY THE APPLICANT.
3. LOCATION AND WIDTH TO BE APPROVED BY THE CITY ON A SITE SPECIFIC BASIS. PLACE A MARKER, AS INDICATED, AT THE CENTER OF THE PROPOSED DRIVEWAY FOR INITIAL INSPECTION BY THE CITY.



SCALE:
NTS
APPROVED:
RAR
REVISED:
11/29/02

TYPICAL SIGHT DISTANCE AT GRAVEL DRIVEWAY

SECTION #

DETAIL #
20-12

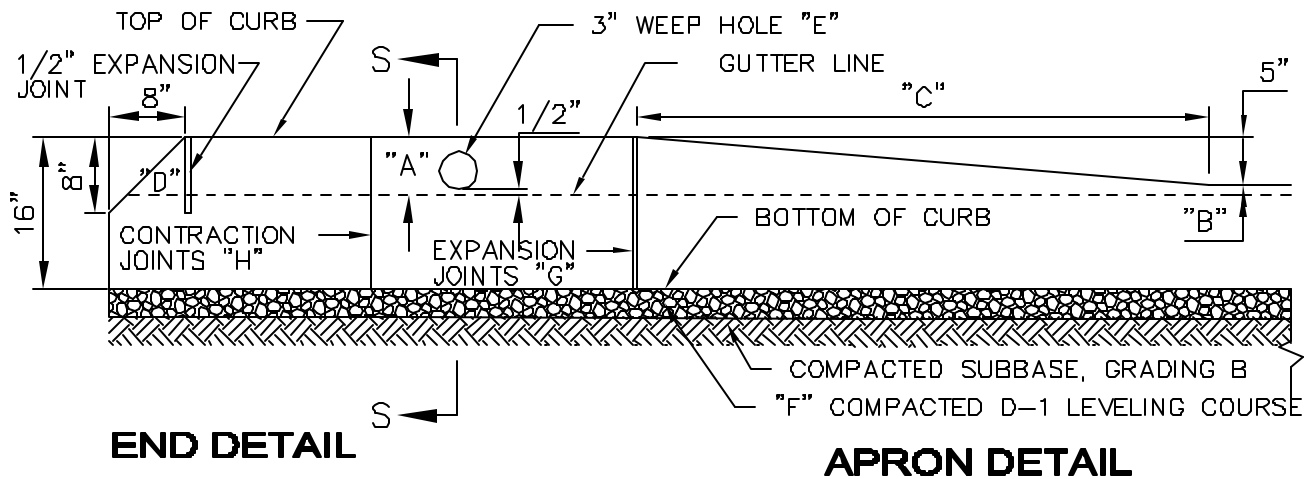

END DETAIL

APRON DETAIL

NOTES:

1. "A" CURB EXPOSURE, STANDARD 6", VARY AS SHOWN ON TYPICAL SECTION, OR AS DIRECTED.
 - "B" CURB EXPOSURE ADJACENT TO DRIVEWAY, STANDARD 1", OR AS DIRECTED.
 - "C" DRIVEWAY APRON, STANDARD RESIDENTIAL & COMMERCIAL 6' MIN, OR AS DIRECTED.
 - "D" END CURB SECTION, TOP TO BE REMOVED UPON EXTENSION OF CURB.
 - "E" WEEP HOLE, 3" PLASTIC DRAIN PIPE OR APPROVED EQUIVALENT, LOCATED AS INDICATED ON THE PLANS OR AS DIRECTED. DRAIN PIPE SHALL HAVE A BELL OR A 3" EXTENSION, FOR FUTURE HOOK-UP.
 - "F" BASE COURSE, GRADING D-1
 - "G" EXPANSION JOINTS, MAX. 30' SPACING AND AT BEGINNING AND END OF CURVES OR AS DIRECTED.
 - "H" CONTRACTION JOINTS, MAX. 10' SPACING AND AT LOCATIONS AS DIRECTED.
2. CURB TO BE CLASS A PORTLAND CEMENT CONCRETE.
 3. CONCRETE AND MISC. MATERIALS USED IN CURB CONSTRUCTION SHALL CONFORM TO CURRENT APWA STANDARD SPECIFICATIONS.

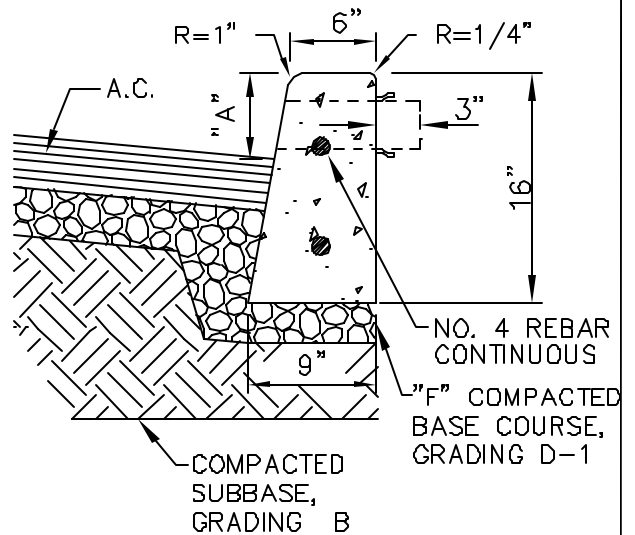

SECTION S-S



SCALE:
NTS
APPROVED:
RAR
REVISED:
11/29/02

**STANDARD VERTICAL CURB
TYPE "C"**

SECTION #
30.02
DETAIL #
30-1

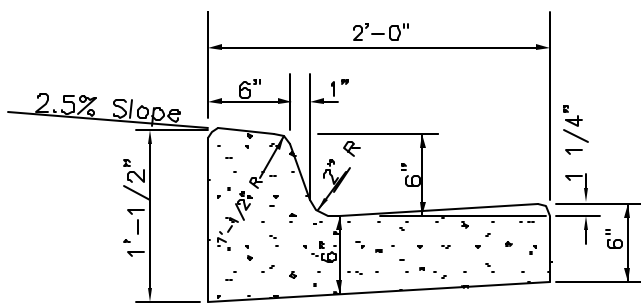

**CURB & GUTTER
TYPE 1**

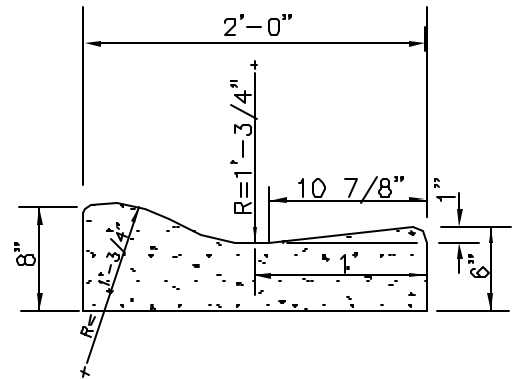

**ROLLED CURB & GUTTER
TYPE 2**

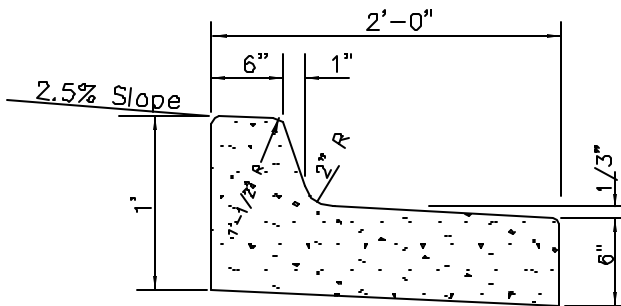

**CURB & GUTTER
TYPE 3**

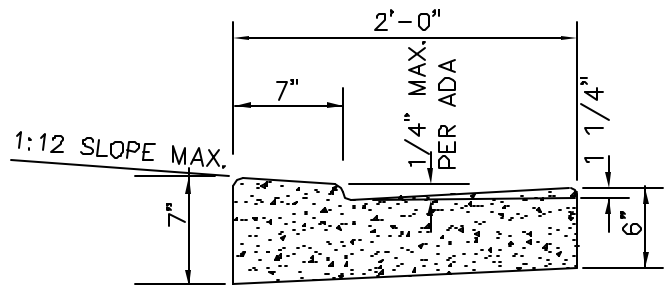

**DEPRESSED CURB & GUTTER
(USED AT CURB CUTS AND ADA RAMPS)
TYPE 4**

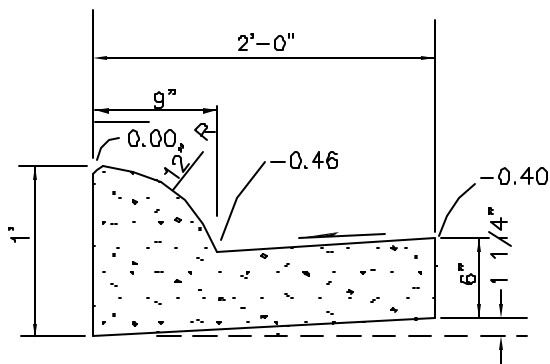

**CURB & GUTTER
TYPE 5**

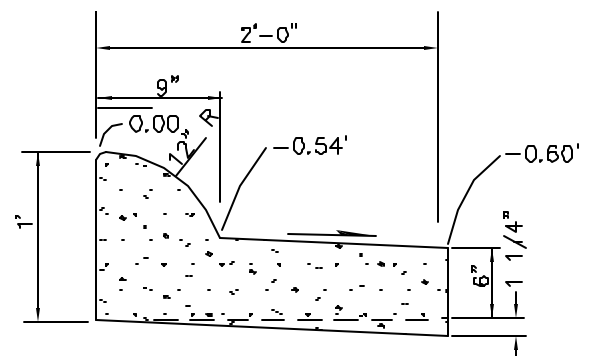

**CURB & GUTTER
TYPE 6**

NOTE:
BOTH FRONT AND BACK EDGES OF THE CURB & GUTTER SHALL BE
TROWELED TO A RADIUS OF ONE-HALF (1/2) INCH.



SCALE:
NTS
APPROVED:
RAR
REVISED:
11/29/02

CURB AND GUTTER CROSS SECTIONS

SECTION #
30.02
DETAIL #
30-2

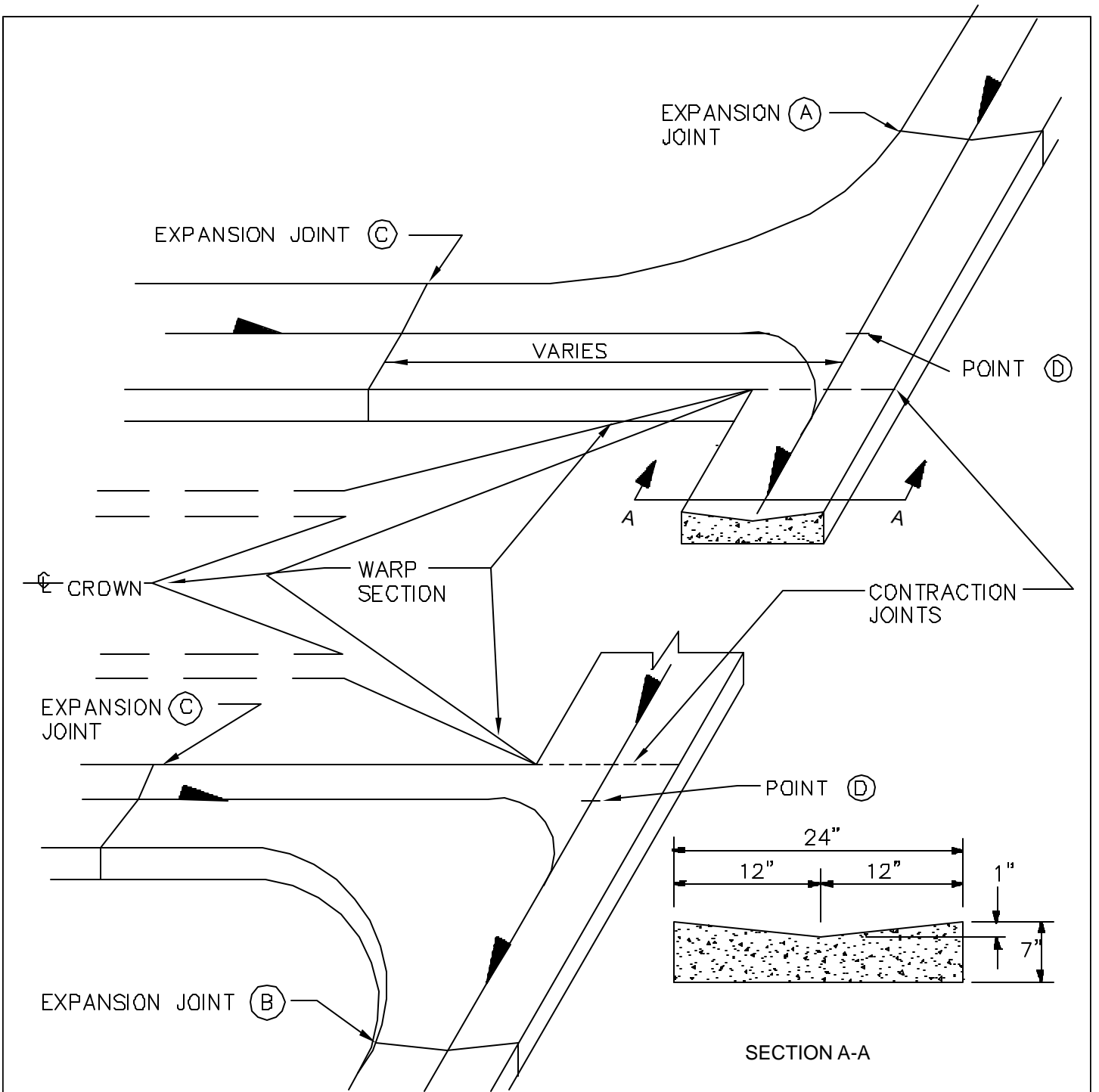

NOTE:

P.C.C. VALLEY GUTTER WILL BE PAID FOR PER LINEAR FOOT UNDER BID ITEM "P.C.C. VALLEY GUTTER". LENGTHS SHALL BE MEASURED ALONG THE STRAIGHT FLOW LINE BETWEEN EXPANSION JOINTS "A&B" AND FROM EXPANSION JOINT "C" TO THE INTERSECTION OF THIS STRAIGHT FLOW LINE (POINT "D") BOTH SIDES.



SCALE:
NTS
APPROVED:
RAR
REVISED:
11/29/02

P.C.C. VALLEY GUTTER

SECTION#
30.02
DETAIL #
30-3

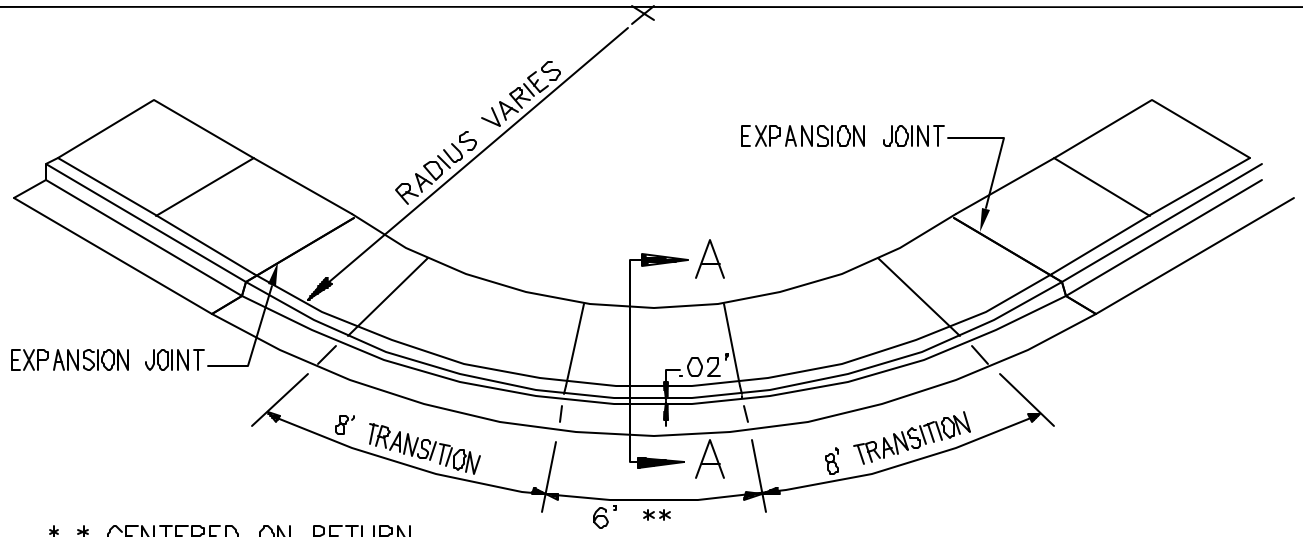

** CENTERED ON RETURN

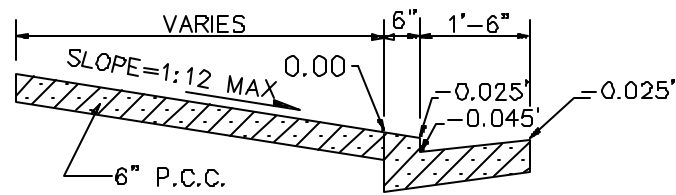
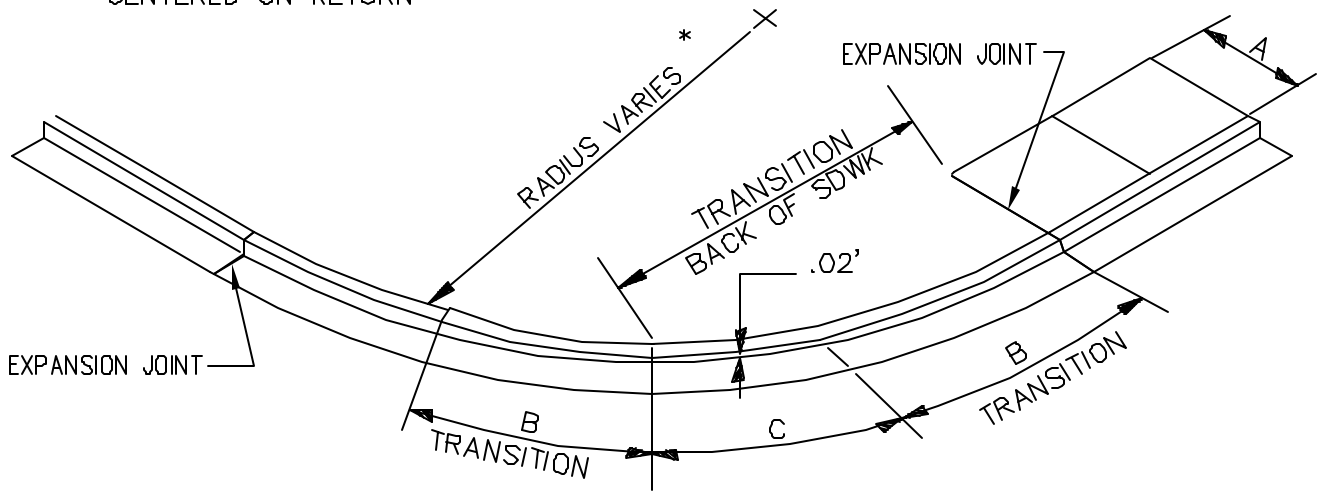

SECTION A-A

RADIUS*	A	B	C
15'	4'	5.5'	5.7'
20'	4'	6.4'	6.5'
20'	5'	9.0'	5.5'
25'	4'	7.1'	7.2'
25'	5'	10.1'	6.0'
30'	4'	7.8'	7.9'
30'	5'	11.0'	6.6'



SCALE:
NTS
APPROVED:
RAR
REVISED:
11/29/02

STANDARD CURB RETURN

SECTION #
30.02
DETAIL #
30-4

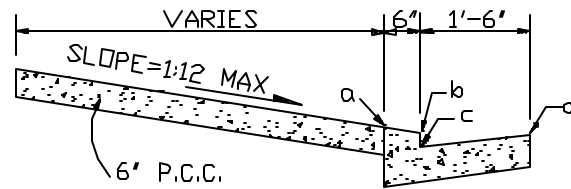
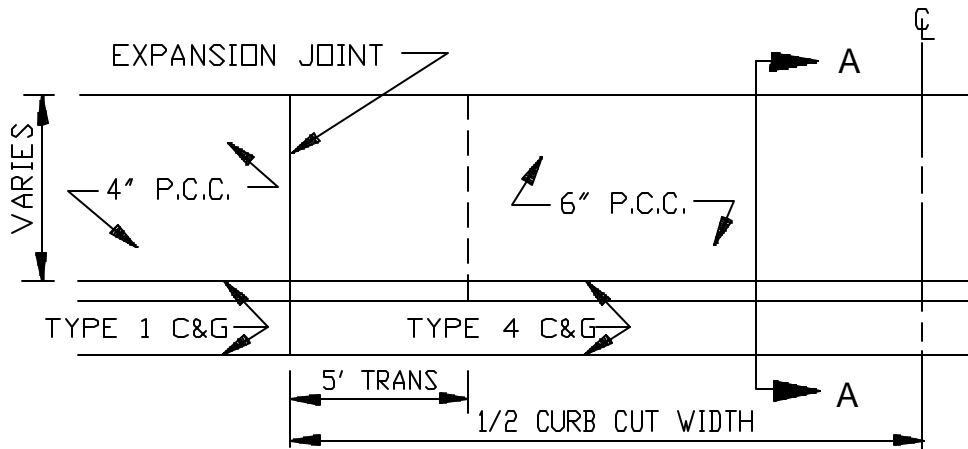
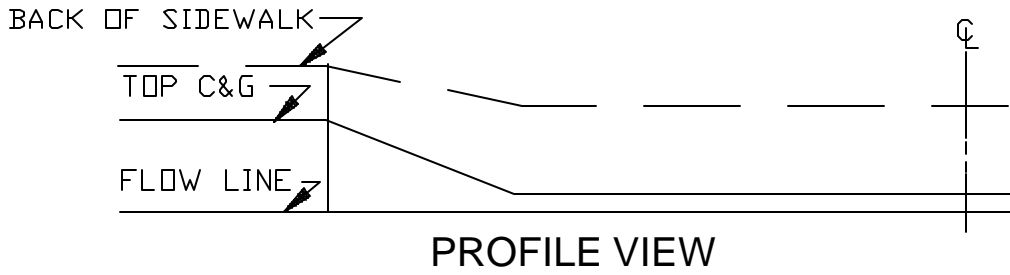

a	b	c	d
0.00	-0.025'	-0.045'	-0.025'



SCALE:
NTS
APPROVED:
RAR
REVISED:
11/29/02

STANDARD CURB-CUT AND ALLEY RETURN

SECTION#
30.02
DETAIL #
30-5

SEAL ALL JOINTS BETWEEN
CONCRETE AND ASPHALT

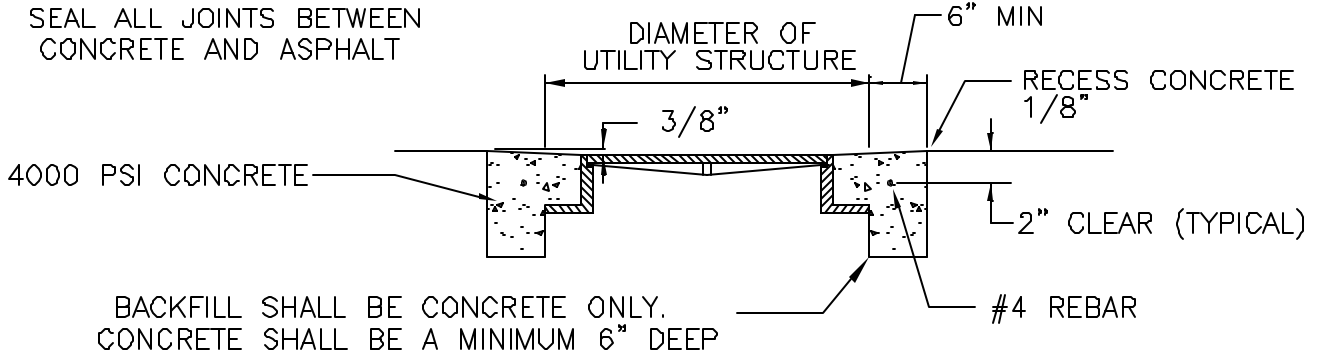

SECTION A-A

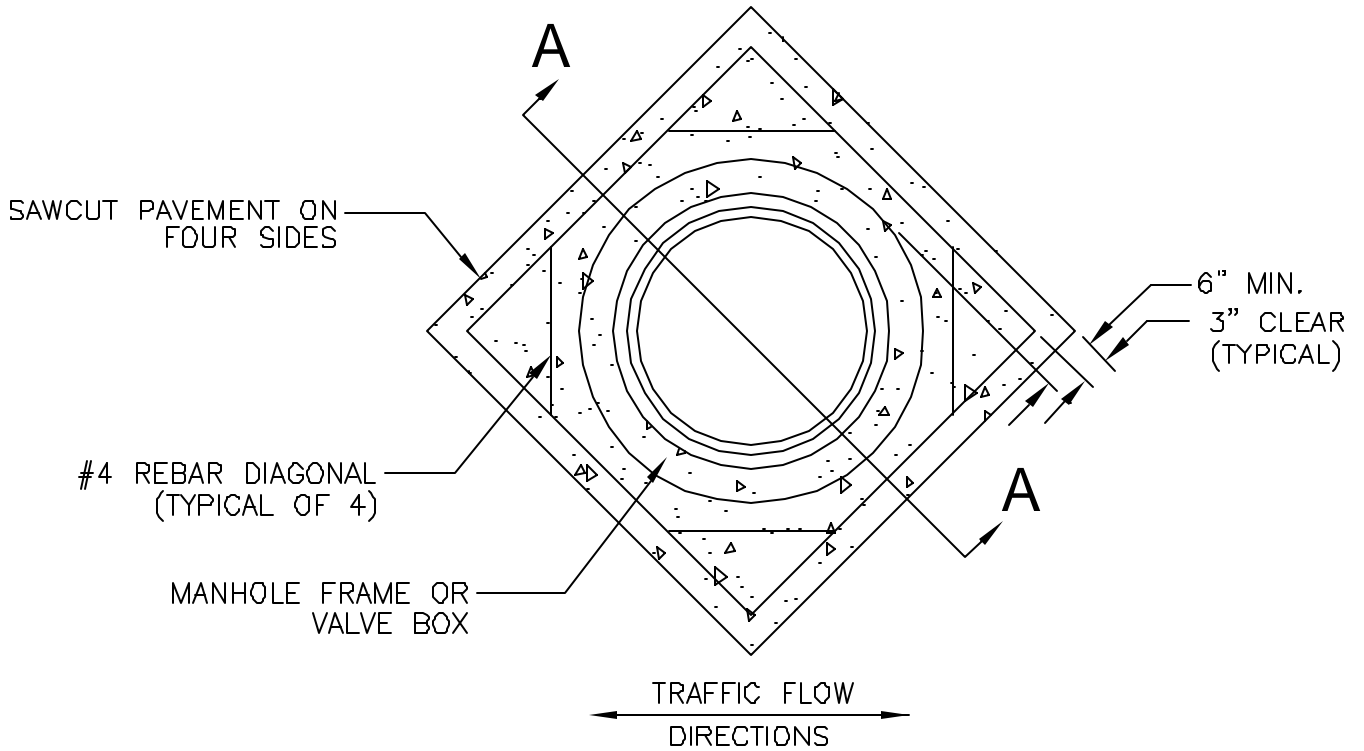

PLAN VIEW

NOTES:

1. INSTALL CONCRETE COLLAR AROUND ALL UTILITY STRUCTURES THAT LIE WITHIN PAVED ROADWAYS.
2. AFTER ADJUSTING STRUCTURE TO FINISH GRADE, BACKFILL WITH CONCRETE ONLY.
3. CURING COMPOUND SHALL BE APPLIED TO THE CONCRETE. APPLICATION SHALL CONFORM TO THE MANUFACTURER'S RECOMMENDATIONS.
4. ALL STRUCTURES SHALL BE RAISED TO BASE COURSE GRADE PRIOR TO PAVING.



SCALE:
NTS
APPROVED:
RAR
REVISED:
11/29/02

UTILITY STRUCTURE COLLAR DETAIL

SECTION #
30.02
DETAIL #
30-6

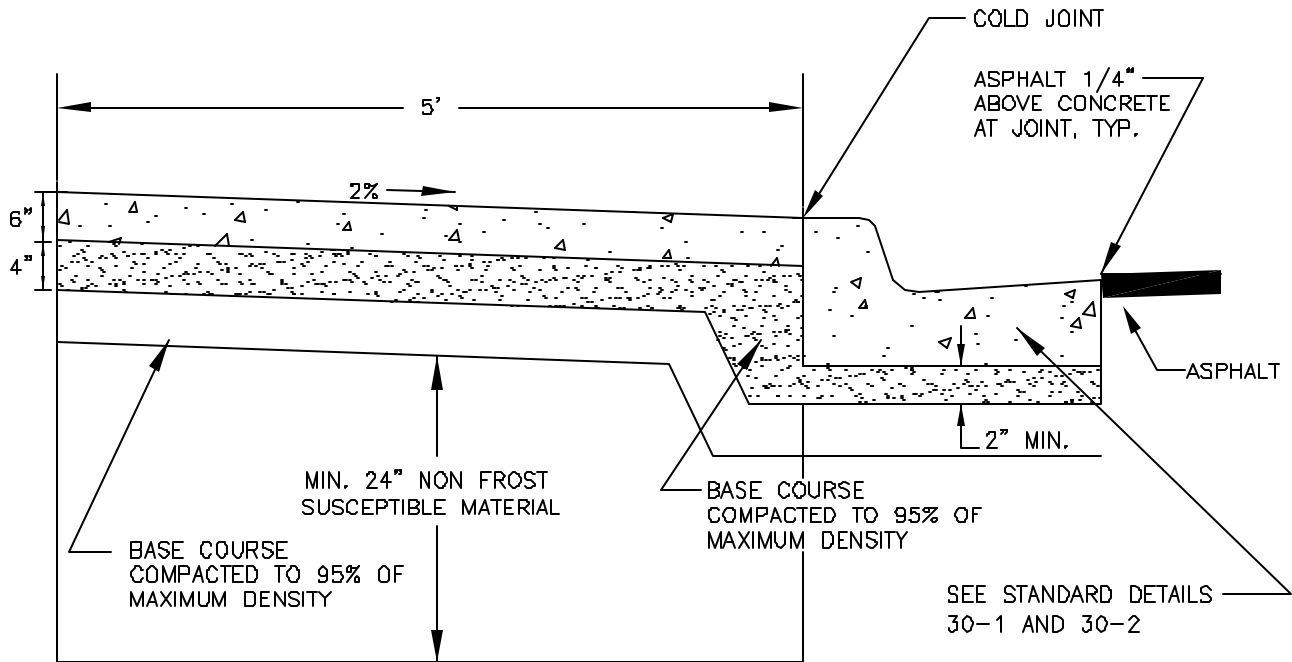

NOTES:

1. WHEELCHAIR ACCESS RAMPS SHALL BE REQUIRED ON ALL NEW SIDEWALK CONSTRUCTION AT CROSSWALKS AND INTERSECTIONS.
2. CURB AND GUTTER TRANSITION DESIGN TO BE APPROVED BY THE ENGINEER.
3. ALL STEEL MUST HAVE A MINIMUM OF 2" OF CONCRETE COVER.
4. ALL JOINTS AND SEAMS SHALL BE EDGED.
5. EXPANSION JOINTS SHALL BE 1/2", FILLED WITH AN EPOXY GROUT SEALANT, WITH NO GAPS FOR WATER INTRUSION. JOINTS SHALL BE A MAXIMUM OF 30' O.C.
6. STEEL TROWELING FINISH REQUIRED PRIOR TO BROOM FINISHING ON ALL SURFACES.
7. CURING COMPOUND SHALL BE APPLIED TO THE CONCRETE. APPLICATION SHALL CONFORM TO THE MANUFACTURER'S RECOMMENDATIONS.



SCALE:
NTS
APPROVED:
RAR
REVISED:
11/29/02

CONCRETE SIDEWALK

SECTION#
30.03

DETAIL #
30-7

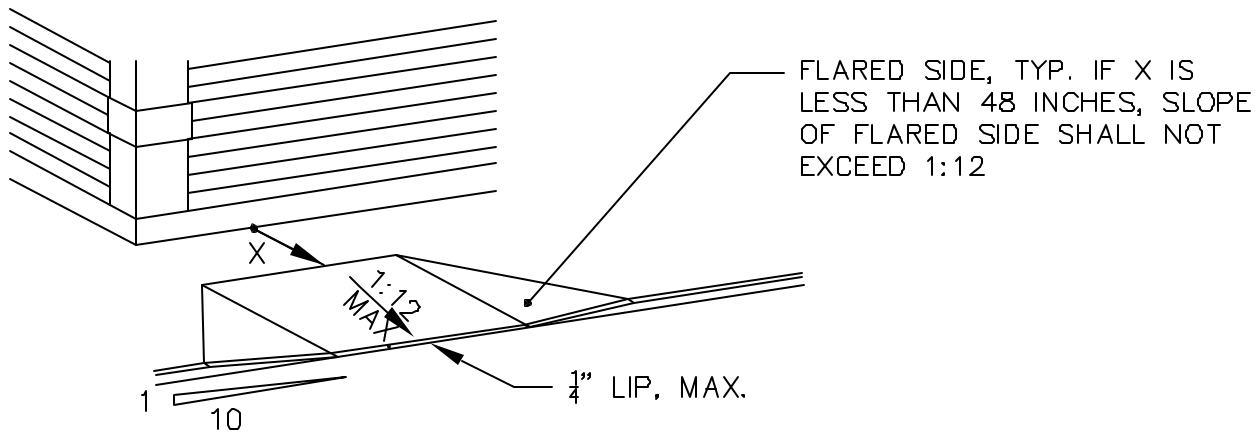

FLARED SIDES

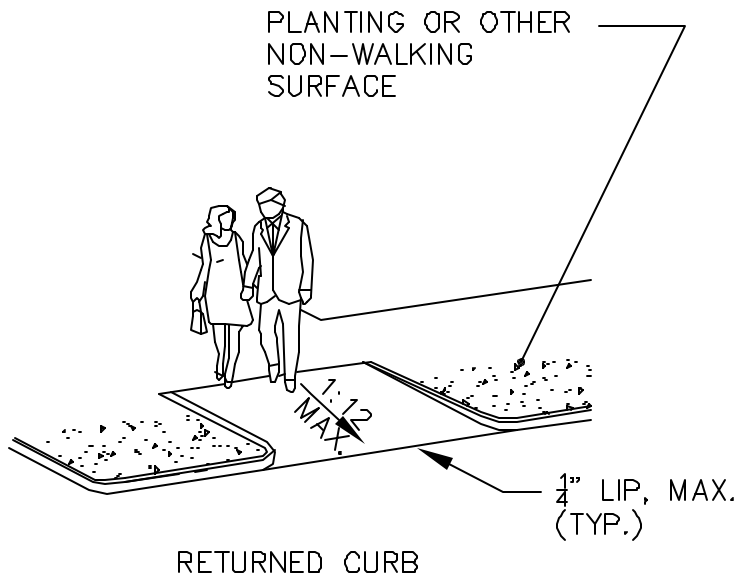

RETURNED CURB

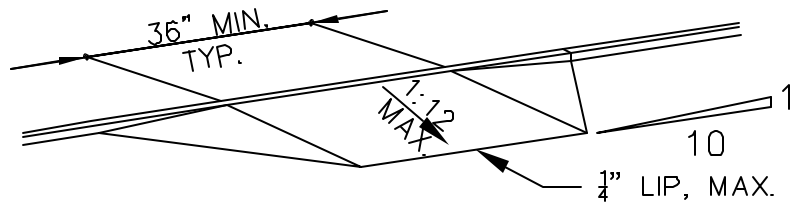

BUILT-UP CURB RAMP

NOTE:
TYPE 4 CURB & GUTTER
SHOWN



SCALE:
NTS
APPROVED:
RAR
REVISED:
11/29/02

ADA ACCESS RAMPS FOR NEW SIDEWALKS

SECTION #
30.03

DETAIL #
30-8

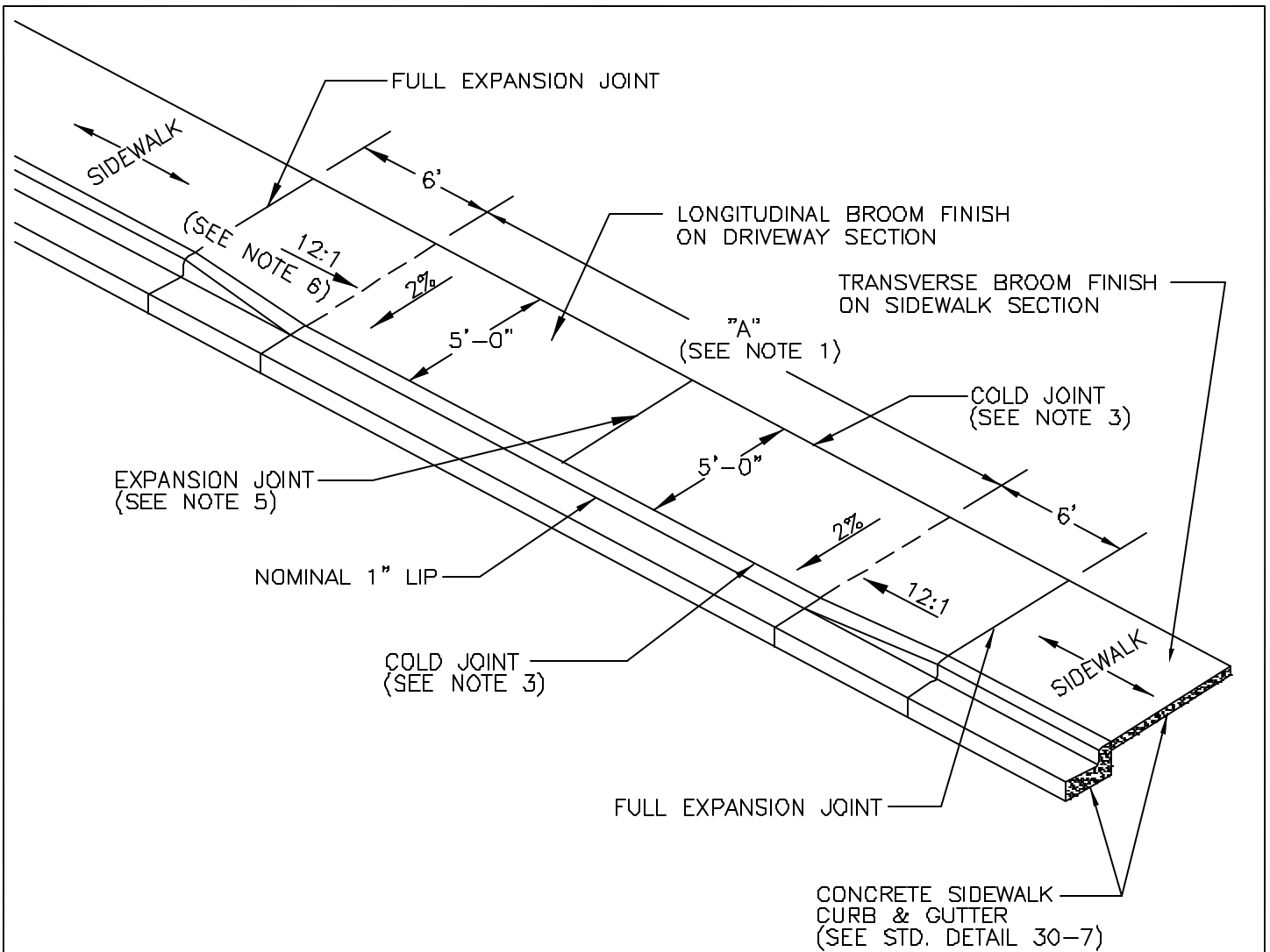

NOTES:

1. "A" EQUALS WIDTH OF DRIVEWAY AT PROPERTY LINE.
2. CURING COMPOUND SHALL BE APPLIED TO THE CONCRETE. APPLICATION SHALL CONFORM TO THE MANUFACTURER'S RECOMMENDATIONS.
3. COLD JOINT REQUIRED BETWEEN SIDEWALK AND DRIVEWAY AND BETWEEN SIDEWALK AND CURB.
4. ALL DRIVEWAY CONCRETE IN THE R.O.W. SHALL BE A MINIMUM 6" THICK AND SHALL BE POURED ON A 6" BASE OF BASE COURSE COMPACTED TO 95% OF ITS MAXIMUM DENSITY.
5. EXPANSION JOINT REQUIRED IF "A" IS GREATER THAN 15'.
6. DRIVEWAY SLOPE AND SIDE SLOPES SHALL NOT BE STEEPER THAN 1:12 (e.g. 5" DROP OVER 5' RUN).



SCALE:
NTS
APPROVED:
RAR
REVISED:
11/29/02

CONCRETE DRIVEWAY

SECTION #
30.03
DETAIL #
30-9

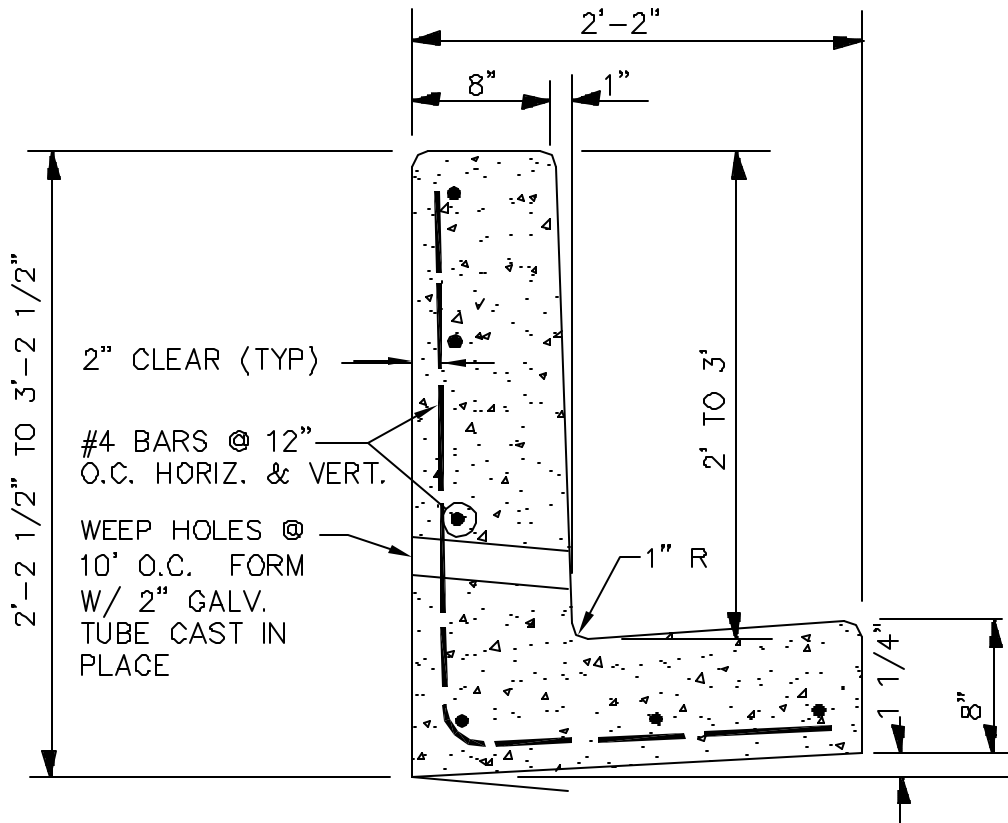

SPECIAL CURB & GUTTER SECTION

NOTE:
 ALL OUTSIDE EDGES SHALL HAVE 3/4" X 3/4" CHAMFERED CORNERS.



SCALE:
 NTS
 APPROVED:
 RAR
 REVISED:
 11/29/02

CURB TYPE RETAINING WALL 2'-0" TO 3'-0" HIGH

SECTION#
 30.04
 DETAIL #
 30-10

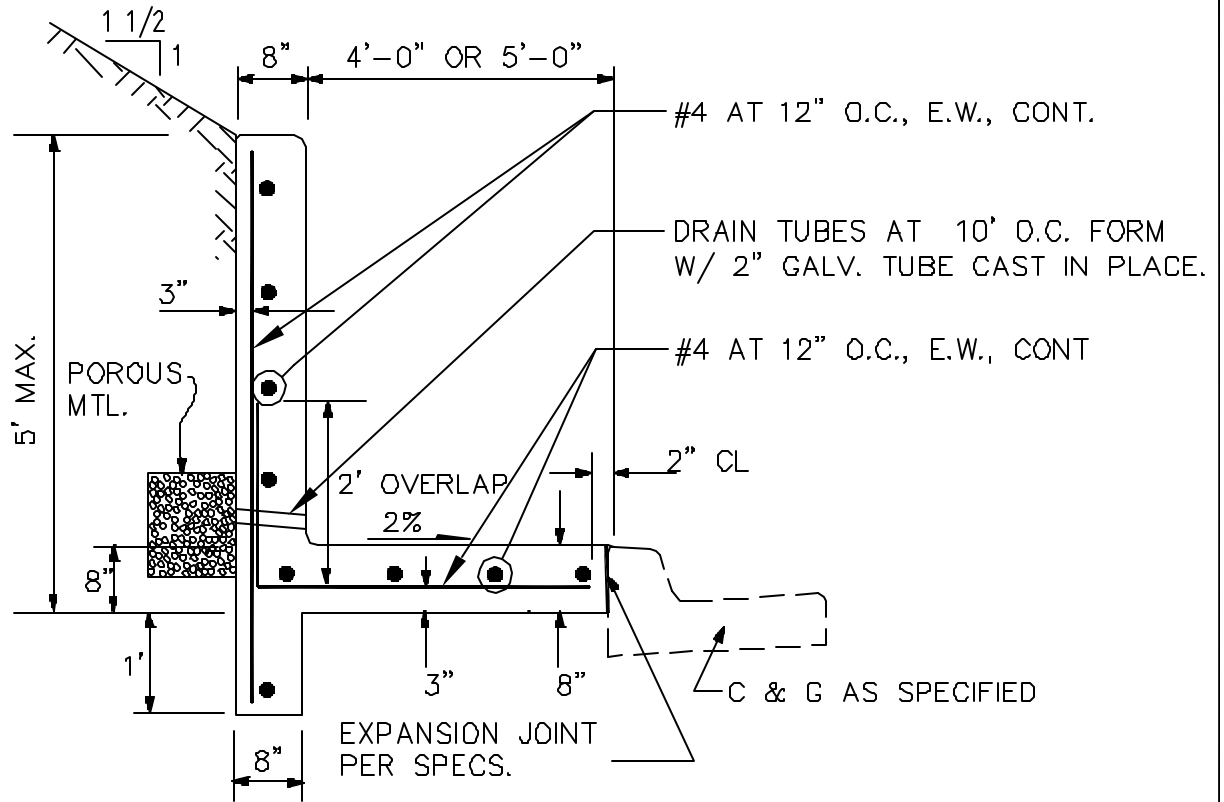

TYPICAL SIDEWALK TYPE RETAINING WALL

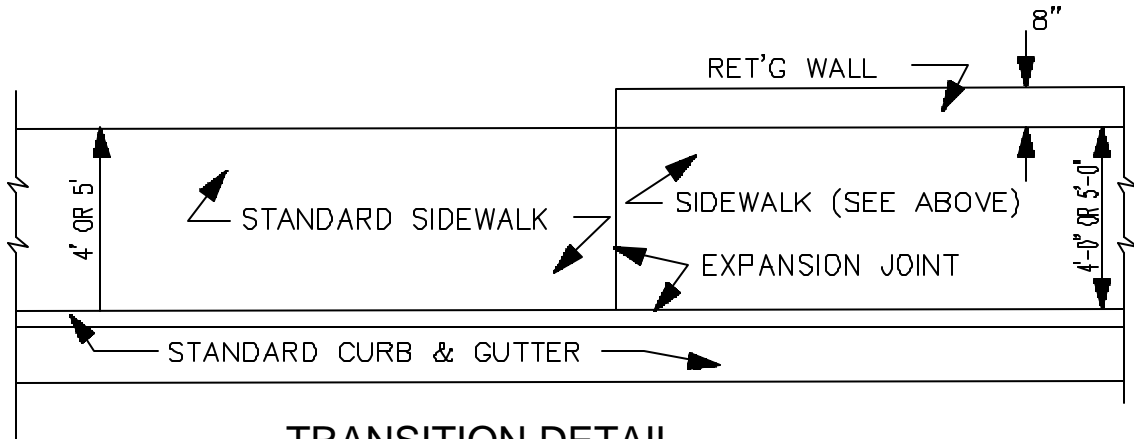

TRANSITION DETAIL
(PLAN VIEW)

NOTES:

1. COST OF STD. C & G SECTION NOT TO BE INCLUDED IN UNIT BID PRICE FOR RETAINING WALL.
2. PLACE ONE CUBIC FOOT OF POROUS BACKFILL MATERIAL AROUND WEEP HOLE AS SHOWN.



SCALE:
NTS
APPROVED:
RAR
REVISED:
11/29/02

TYPICAL SECTION
SIDEWALK TYPE
RETAINING WALL

SECTION#
30.04
DETAIL #
30-11

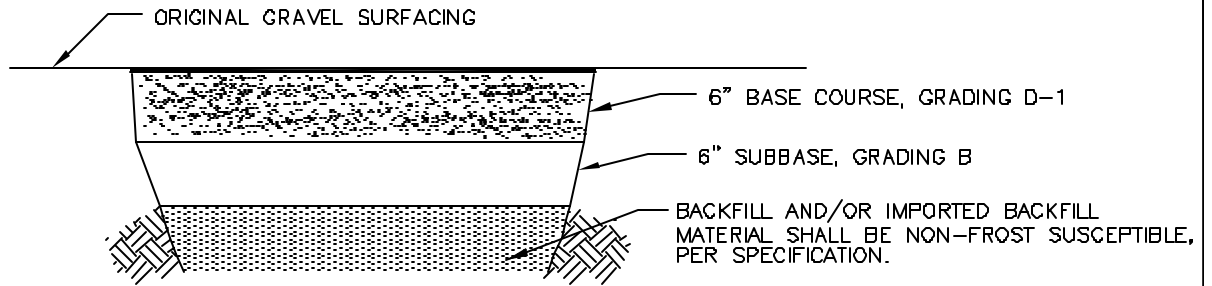

GRAVEL SECTION

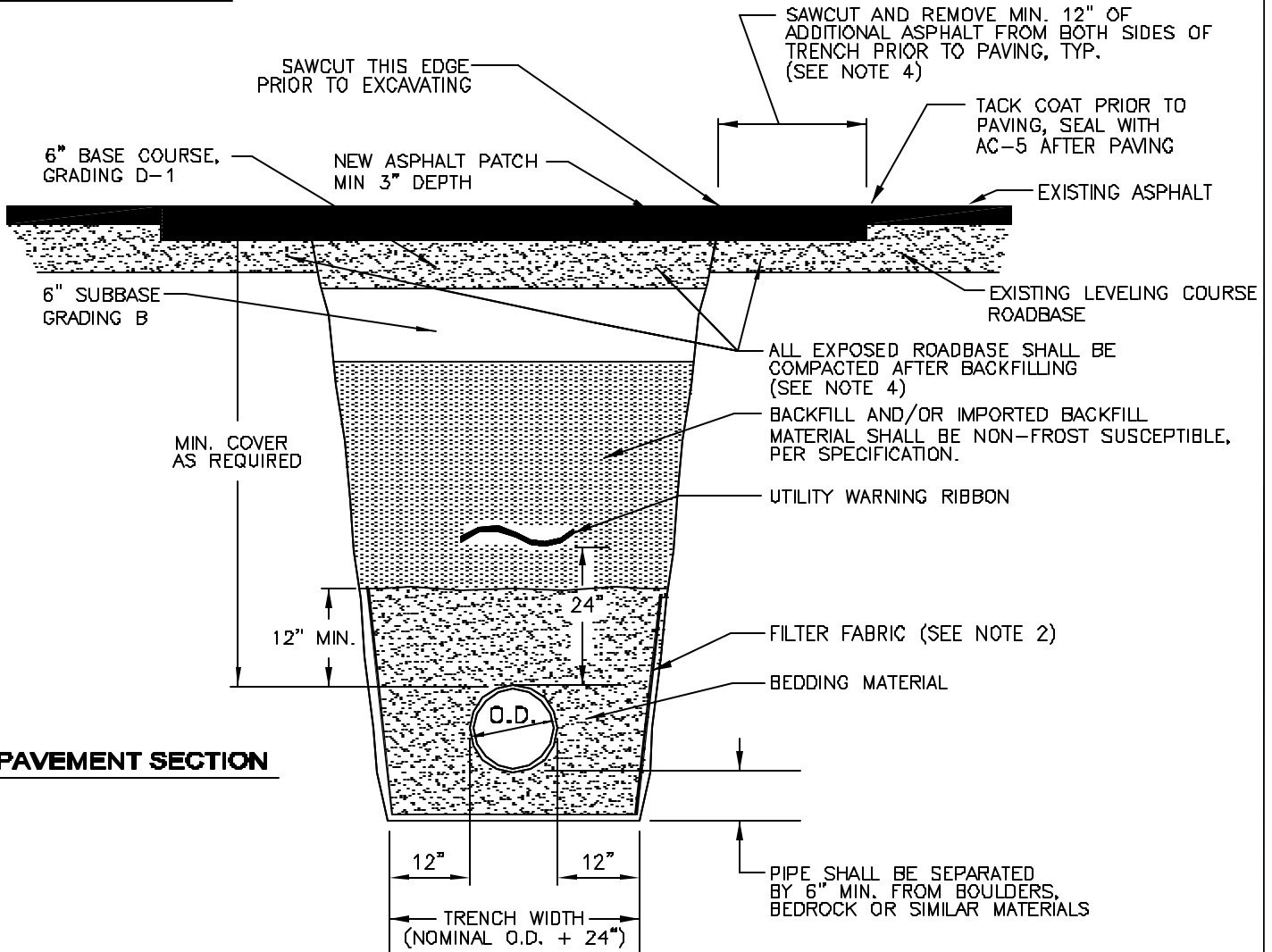

PAVEMENT SECTION

NOTES:

1. TRENCHES SHALL BE WITHIN 20' OF PERPENDICULAR TO CENTER-LINE OF ROADWAY UNLESS APPROVED BY THE ENGINEER.
2. FILTER FABRIC SHALL BE USED AS DIRECTED BY THE ENGINEER. ATTACH TO TRENCH SIDEWALL A MIN OF 12" ABOVE TOP OF PIPE.
3. BEDDING & BACKFILL SHALL BE COMPACTED TO 95% OF MAXIMUM PROCTOR DENSITY WITHIN THE RIGHT-OF-WAY AND THROUGHOUT THE DEPTH OF EACH LIFT. LIFT DEPTH SHALL BE 18" MAX AND APPROVED BY THE ENGINEER.
4. PAVEMENT SHALL BE SAWCUT PRIOR TO EXCAVATING. AFTER BACKFILLING TRENCH, PAVEMENT SHALL BE SAWCUT A SECOND TIME TO EXPOSE A MINIMUM OF 12" OF UNDISTURBED BASE MATERIAL. ENTIRE WIDTH OF EXPOSED ROADBASE SHALL BE COMPACTED TO 95% OF MAXIMUM PROCTOR DENSITY.
5. IF TRENCH IS NOT IMMEDIATELY BACKFILLED AND COMPACTED, REMOVAL OF MORE THAN 12" MIN. OF EXTRA ASPHALT AND FURTHER COMPACTION OF THE ROADBASE SHALL BE REQUIRED BY THE ENGINEER.
6. RESURFACE ASPHALT PAVED STREETS WITH 6" MIN. BASE COURSE AND 3" MIN. ASPHALT.
7. RESURFACE UNPAVED STREETS WITH 6" MIN. BASE COURSE.



SCALE:
NTS
APPROVED:
RAR
REVISED:
11/29/02

**PAVEMENT
RESURFACING AND
TRENCH DETAIL**

SECTION #
40.07
DETAIL #
40-1

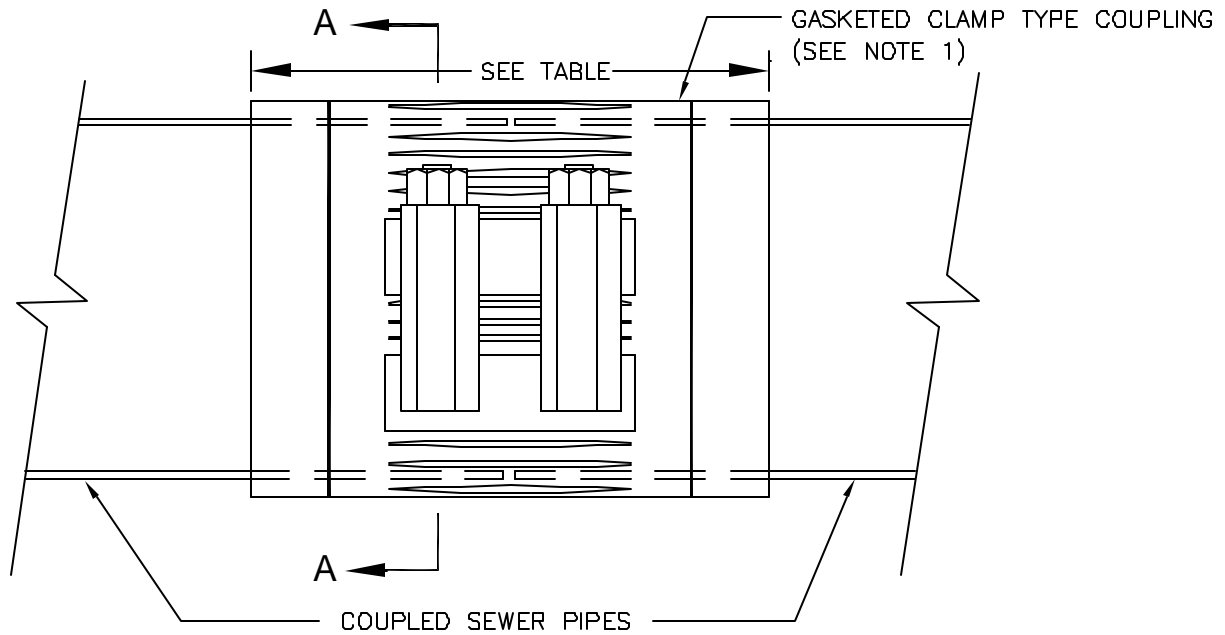

PLAN VIEW

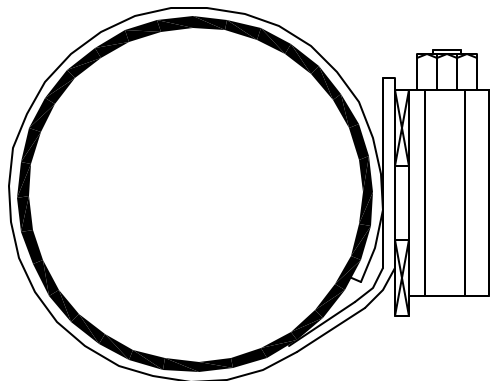

SECTION A-A

PIPE SIZE LENGTH OF CLAMP

4"	8", MIN.
6"	12"
8"	12"
10"	12"
12"	12"
14"	12"
18"	16"
21"	20"
24"	20"
27"	24"
30"	24"

NOTES:

1. USE THIS STANDARD WHEN COUPLING SEWER PIPES WITHIN THE RIGHT-OF-WAY
COUPLING SHALL BE ROMAC INDUSTRIES SS1 12" SEWER CLAMP COUPLING OR APPROVED EQUAL.
2. GASKET SHALL BE VIRGIN SBR COMPOUNDED FOR WATER AND SEWER SERVICE.
3. BOLTS, WASHERS, NUTS, LUG, AND SHELL SHALL BE STAINLESS STEEL.
4. CONNECTED PIPES SHALL BE CUT PERPENDICULAR AND INSERTED INTO COUPLING SO THAT ENDS ARE FLUSH.



SCALE:
NTS
APPROVED:
RAR
REVISED:
11/29/02

COUPLING FOR DISSIMILAR
SANITARY
SEWER PIPES

SECTION#
50.02
DETAIL #
50-1

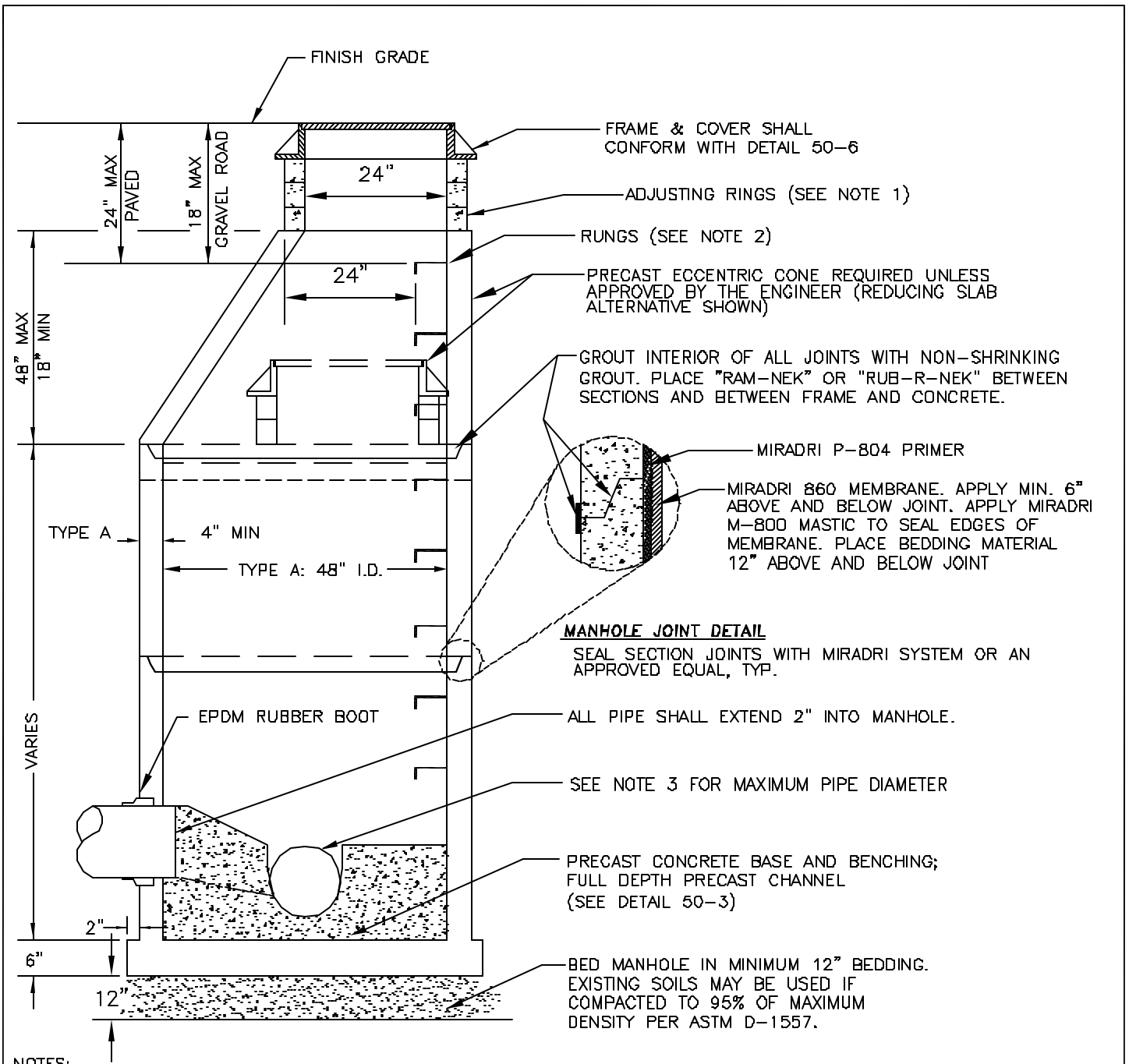

NOTES:

1. USE NO MORE THAN ONE 4" ADJUSTING RING ON NEW CONSTRUCTION ON UNPAVED ROADS, AND NO MORE THAN THREE RINGS ON RECONSTRUCTIONS. NO MORE THAN ONE OF THE NECESSARY ADJUSTING RINGS SHALL BE 4". APPLY WATERPROOF MASTIC AND MEMBRANE AROUND RINGS.
2. RUNGS TO BE PLACED 12" O.C. ON UNOBSTRUCTED SIDE OF MANHOLE. LAST RUNG SHALL BE 18" MAX FROM BOTTOM OF MANHOLE, AND TOP RUNG SHALL BE 6" MAXIMUM FROM TOP OF CONE. IF UNOBSTRUCTED SIDE NOT AVAILABLE, LAST RUNG SHALL BE PLACED 6" OVER SMALLEST PIPE. SEE DETAIL 50-5.
3. PIPE DIAMETERS FOR TYPE A MANHOLES SHALL BE 8"-24". FOR LARGER PIPES, USE TYPE B MANHOLE.
4. REFER TO A.S.T.M. C-478 FOR DESIGN REQUIREMENTS AND C-478-69 FOR MINIMUM STEEL FOR BARREL. FIRST BARREL SECTION SHALL BE IMBEDDED IN BASE. BLOCKOUTS SHALL BE FORMED.
5. DENSITY OF BACKFILL SHALL BE 95% OF MAXIMUM PROCTOR DENSITY.



SCALE:
NTS
APPROVED:
RAR
REVISED:
11/29/02

SANITARY MANHOLE TYPE A PIPE DIA. 8" TO 24"

SECTION #
50.03
DETAIL #
50-2

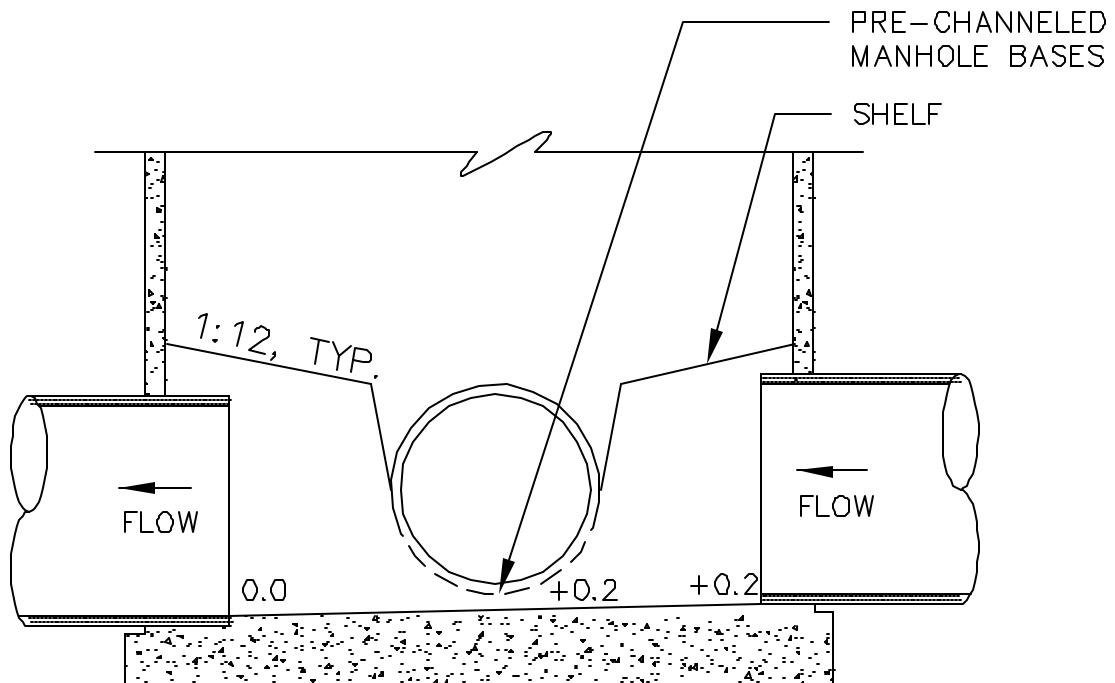
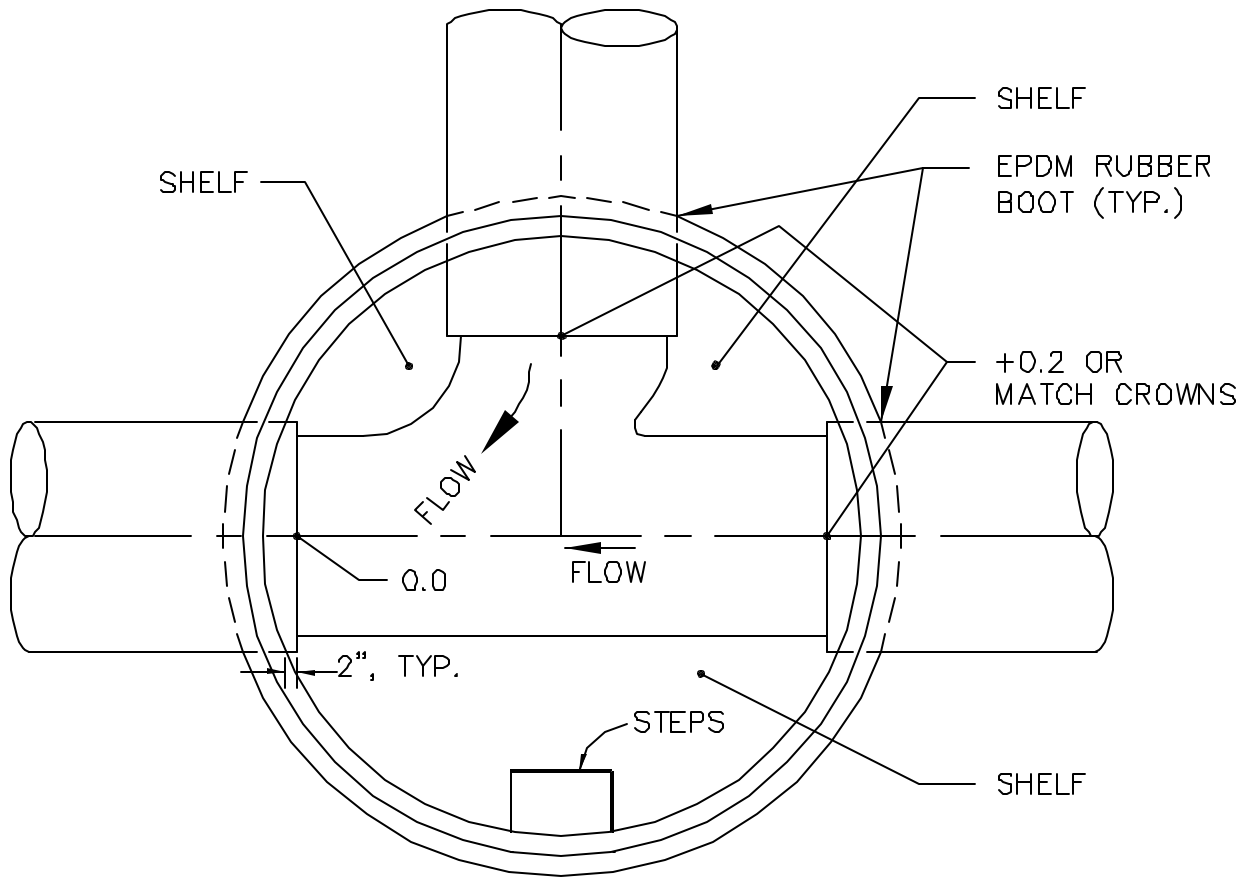

SCALE:
NTS
APPROVED:
RAR
REVISED:
11/29/02

TYPE A MANHOLE BASE PLAN

SECTION#
50.03

DETAIL #
50-3

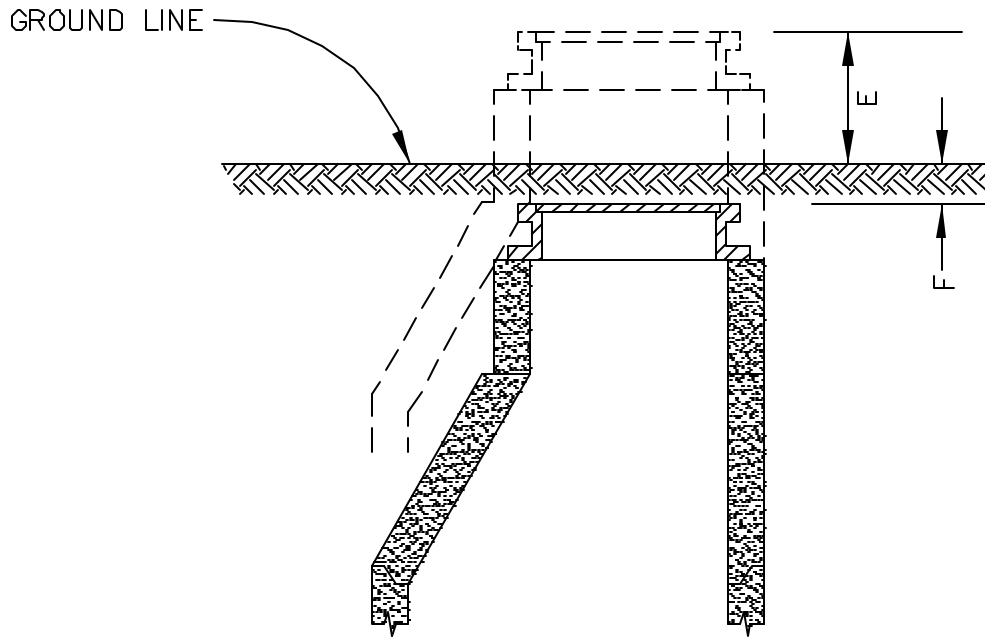

LOCATION	E	F
BACKYARDS, GRAVEL STREETS, AND ALLEY AREAS WHERE TRAVELED.		6" (NO GRADE RINGS)
UNDEVELOPED AND SWAMPY AREAS.	24" MIN	
HIGHWAY R.D.W.S OUTSIDE TRAFFIC AREAS.	6"	
PAVED STREETS.		1/4"



SCALE:
NTS
APPROVED:
RAR
REVISED:
11/29/02

MANHOLE HEIGHTS

SECTION #
50.03

DETAIL #
50-4

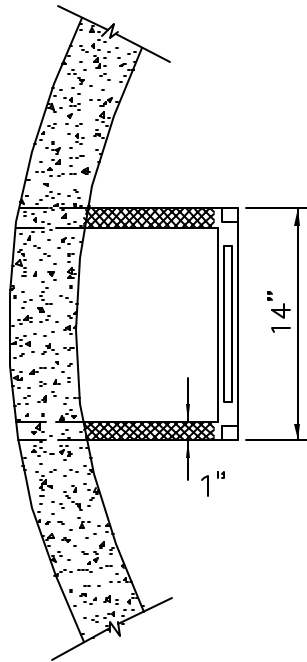

NOTE:
 STEPS SHALL BE LANE POLYETHYLENE 14"
 LADDER STEPS, OR APPROVED EQUAL.
 STEPS SHALL BE INSTALLED IN
 ACCORDANCE WITH MANHOLE STEP
 MANUFACTURER'S RECOMMENDATIONS.

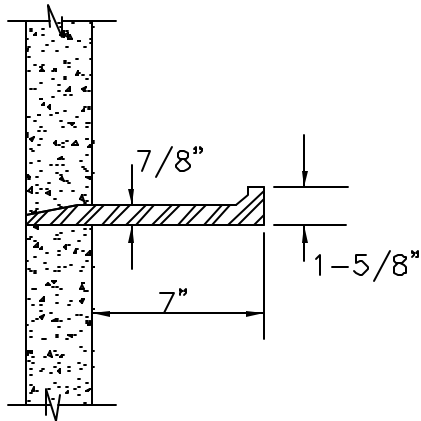

SCALE:
 NTS
 APPROVED:
 RAR
 REVISED:
 11/29/02

MANHOLE STEP

SECTION #
 50.03

DETAIL #
 50-5

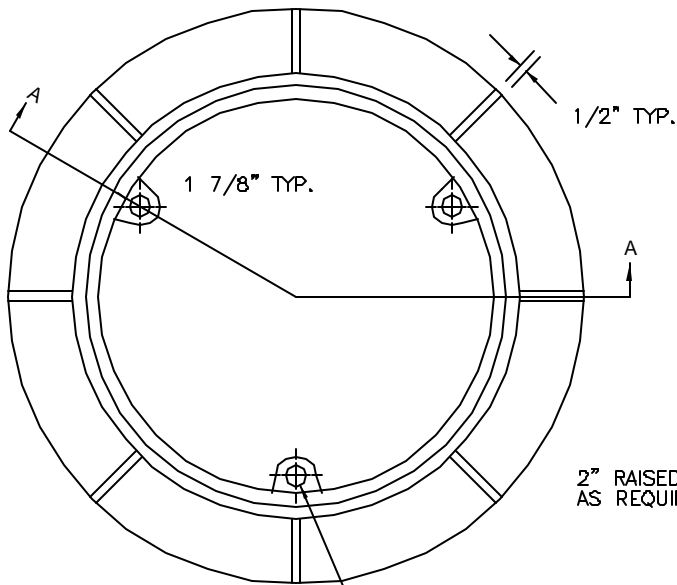

DRILL & TAP: 5/8" - 11 N.C. ON 23" B.C. (TYP. 3 PL.)

FRAME PLAN VIEW

FOR 5/8" - 11 N.C. x 1/4" S.S. SOC. HD. CAP SCREW (THREE REQUIRED)

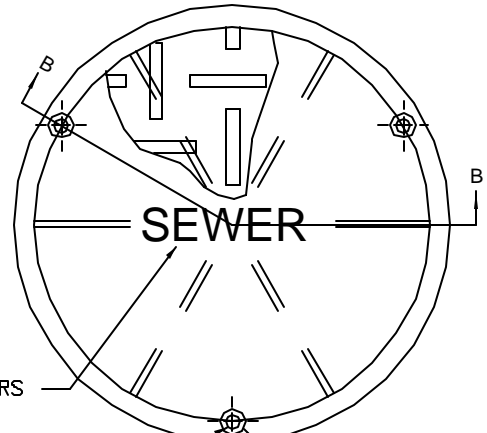

2" RAISED LETTERS AS REQUIRED

3/4" CORE (TYP.) ON 23" B.C. 1 1/2" CORE (TYP.)

COVER PLAN VIEW

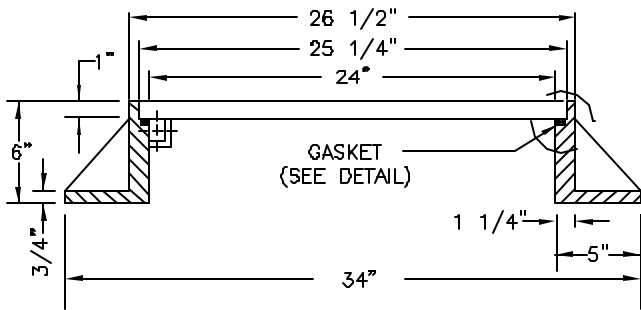

SECTION A-A

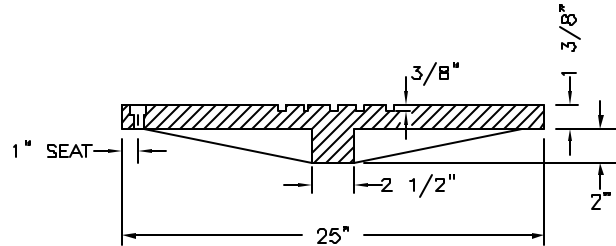

SECTION B-B

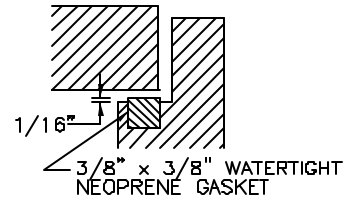

GASKET DETAIL

NOTES:

1. FRAME MUST BE MACHINED TO FIT WATERTIGHT NEOPRENE GASKET.
2. COVER SHALL HAVE THE WORD(S) "SEWER", "WATER", OR "STORM SEWER" CAST IN, SHALL HAVE NO HOLES, AND SHALL BE PROVIDED WITH AN INTEGRAL POCKET LIFT HANDLE.
3. FRAME AND COVER DIMENSIONS SHALL BE IN ACCORDANCE WITH OLYMPIC CONSTRUCTION CASTINGS NO. MH3DW/T WATERTIGHT BOLT-DOWN LID, OR AN APPROVED EQUAL.
4. FRAME AND GRATE SHALL BE GRAY CAST OR DUCTILE IRON.
5. FRAME AND GRATE SHALL BE OF A TYPE THAT WILL NOT CREATE A HAZARD FOR BICYCLE TRAFFIC.



SCALE:
NTS
APPROVED:
RAR
REVISED:
11/29/02

SANITARY SEWER LOCKING MANHOLE COVER & FRAME

SECTION #
50.04

DETAIL #
50-6

DROP MANHOLE	
SEWER DIA. D1	DROP DIA. D2
8"	8"
10"	10"
12"	12"
15"	12"
18"	15"
21"	15"
24"	18"
30"	21"
36"	24"

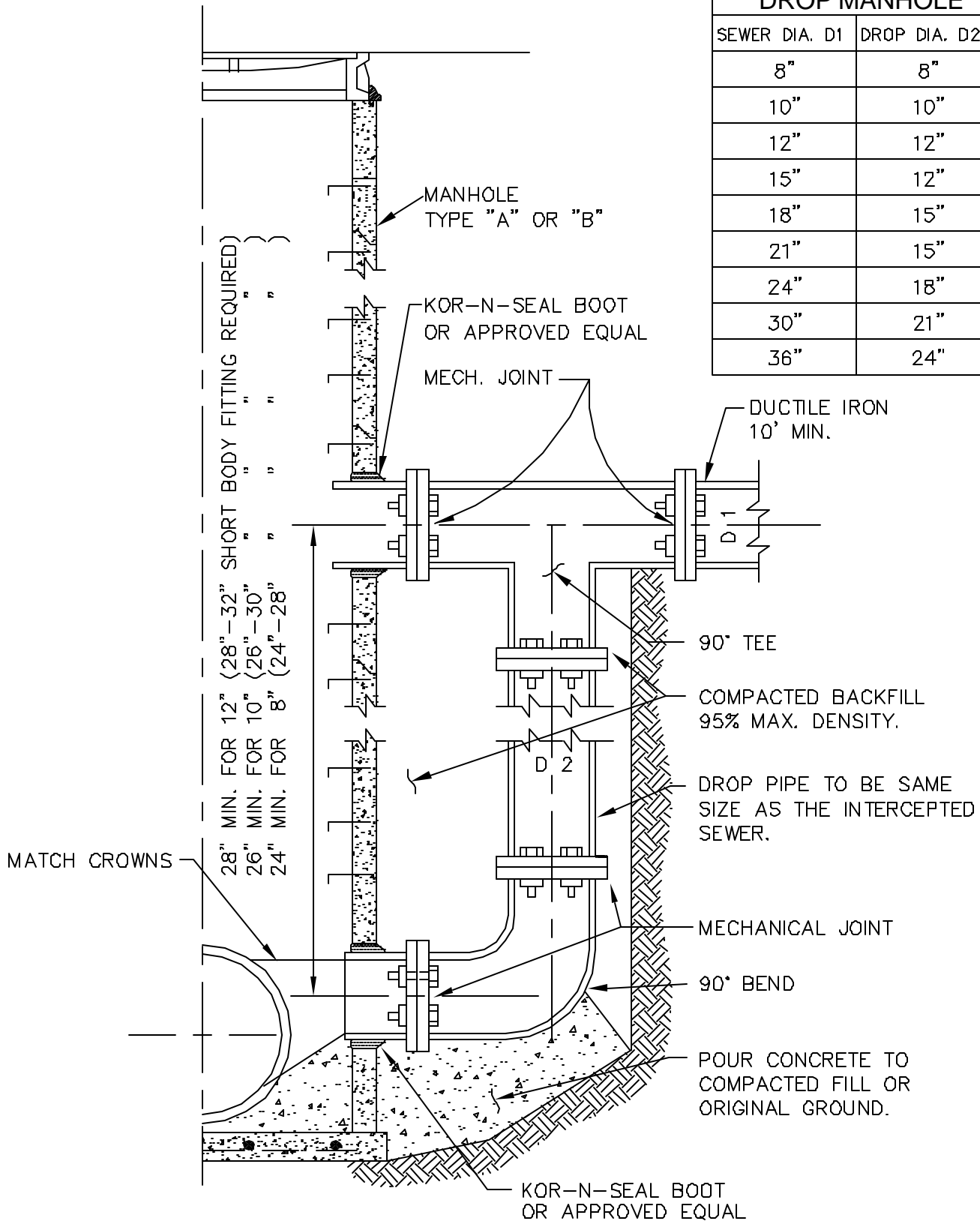

SCALE:
 NTS
 APPROVED:
 RAR
 REVISED:
 11/29/02

EXTERIOR DROP CONNECTION TYPE A MANHOLE

SECTION#
 50.06
 DETAIL #
 50-7

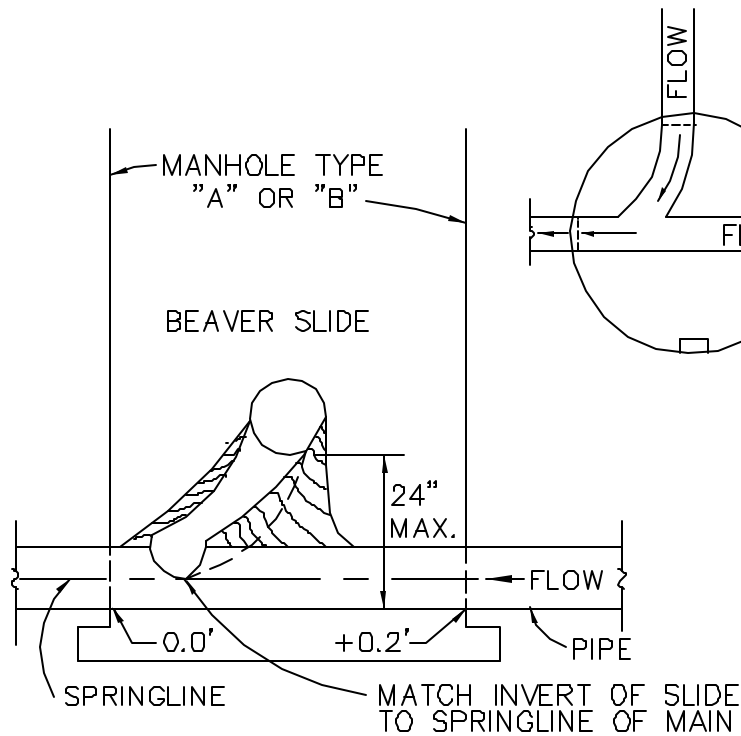

WHEN INSTALLING A BEAVER SLIDE THAT INTERCEPTS AN EXISTING SEWER AT A RIGHT ANGLE, THE CONNECTING INVERT OF THE BEAVER SLIDE IS TO INTERCEPT THE EXISTING SEWER SLIGHTLY ABOVE THE SPRINGLINE AS SHOWN. DISTANCE MEASURED FROM INVERT TO INVERT.

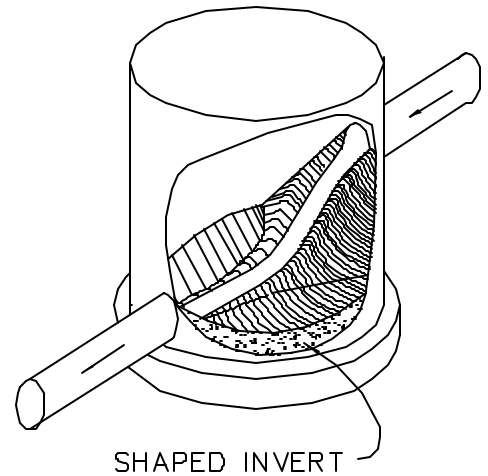
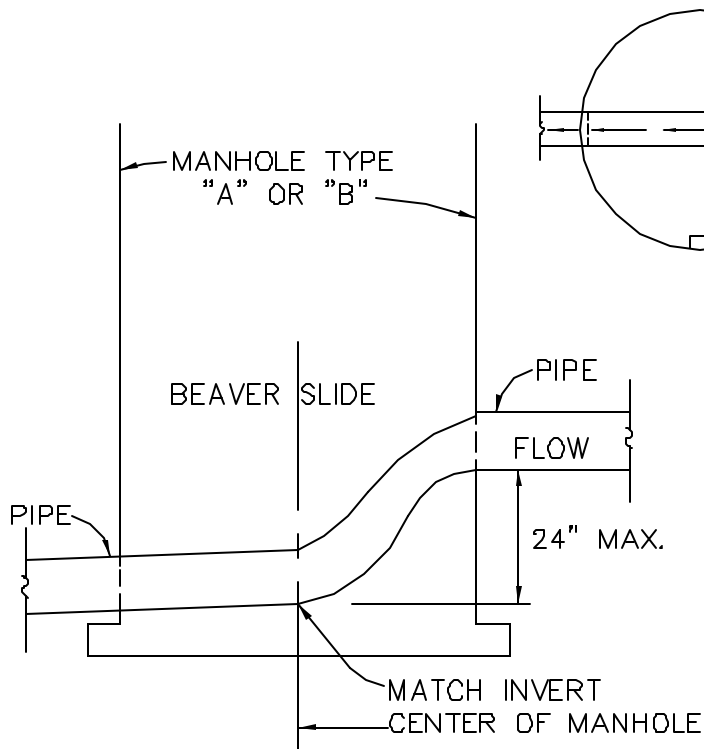

WHEN INSTALLING A BEAVER SLIDE WHERE THE FLOW IS STRAIGHT THROUGH THE MANHOLE, THE BEAVER SLIDE IS TO MATCH THE INVERT OF THE EXISTING LINE AND NOT TO EXTEND MORE THAN HALF-WAY THROUGH THE MANHOLE. DISTANCE MEASURED FROM INVERT TO INVERT.



SCALE:
NTS
APPROVED:
RAR
REVISED:
11/29/02

TYPICAL BEAVER SLIDE TYPE A MANHOLE

SECTION #
50.07
DETAIL #
50-8

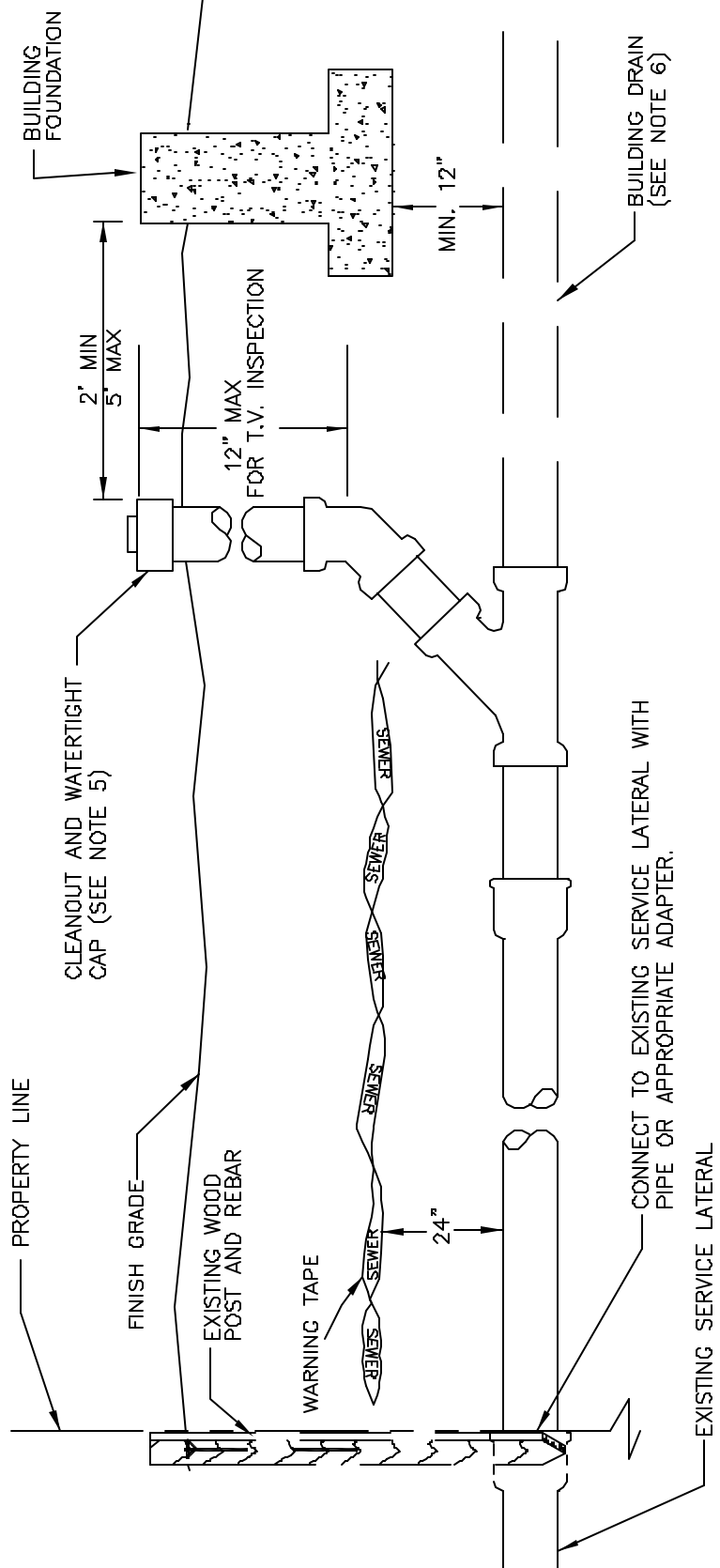

NOTES:

1. WHERE DEPTH TO TOP OF PIPE MUST BE LESS THAN 44" INSULATION SHALL BE REQUIRED AS APPROVED BY THE ENGINEER.
2. MINIMUM GRADE SHALL BE 2% (1/4" PER FOOT).
3. MINIMUM PIPE DIAMETER SHALL BE 4".
4. ACCEPTABLE MATERIALS FOR PIPE CONSTRUCTION BETWEEN THE PROPERTY LINE AND THE CLEANOUT AT THE FOUNDATION INCLUDE: PVC (SDR 35 OR THICKER), DUCTILE IRON (CLASS 50), AND CAST IRON (CLASS 2200).
5. CLEANOUT CONSTRUCTED OF "WYE" FITTING AND CAP OF SAME MATERIAL AS PIPE SHALL BE CONSTRUCTED WITHIN 2' TO 5' OF BUILDING FOUNDATION. AN EXTRA CLEANOUT SHALL BE REQUIRED FOR EVERY 100' OF PIPE AND FOR EACH AGGREGATE BEND OF 135°.
6. MATERIALS AND INSTALLATION OF THE BUILDING DRAIN SHALL CONFORM TO THE UNIFORM PLUMBING CODE. (NOTE: SDR 35 PVC IS NOT AN APPROVED MATERIAL FOR USE UNDER OR INSIDE THE FOUNDATION).
7. LATERAL DEPTH OF SANITARY SEWER SERVICE AT PROPERTY LINE SHALL ACCOMMODATE EXISTING BUILDING SEWER OR FUTURE BUILDING SITE(S).



SCALE:
NTS
APPROVED:
RAR
REVISED:
11/29/02

LATERAL CONNECTION TO EXISTING SANITARY SEWER PIPE

SECTION #
50.08

DETAIL #
50-9

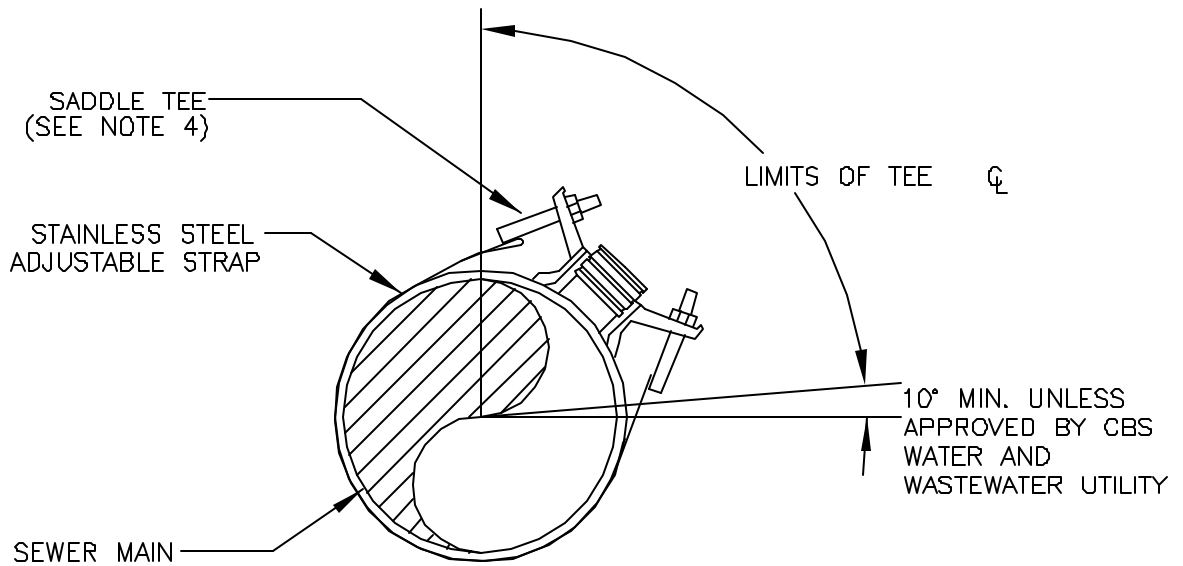

NOTES:

1. DIAMETER OF HOLE CUT IN SEWER MAIN SHALL NOT EXCEED 0.25" LARGER THAN THE SADDLE TEE CONNECTION. TEE SHALL BE CENTERED OVER CUT IN PIPE AND CLAMPED WITH METAL BAND SO TEE GASKET FORMS A WATER-TIGHT SEAL.
2. WATER AND DEBRIS SHALL NOT BE ALLOWED TO ENTER THE SEWER MAIN DURING THE TAPPING OPERATION.
3. THREE (3) MEASURED TIES TO PERMANENT FEATURES AND DISTANCE FROM SADDLE TO MANHOLE MUST BE FURNISHED TO THE CBS ENGINEERING DEPT.
4. SADDLE TEE SHALL BE A ROMAC CB SEWER SADDLE OR AN APPROVED EQUAL.



SCALE:
NTS
APPROVED:
RAR
REVISED:
11/29/02

SANITARY SEWER SADDLE TEE

SECTION #
50.09
DETAIL #
50-10

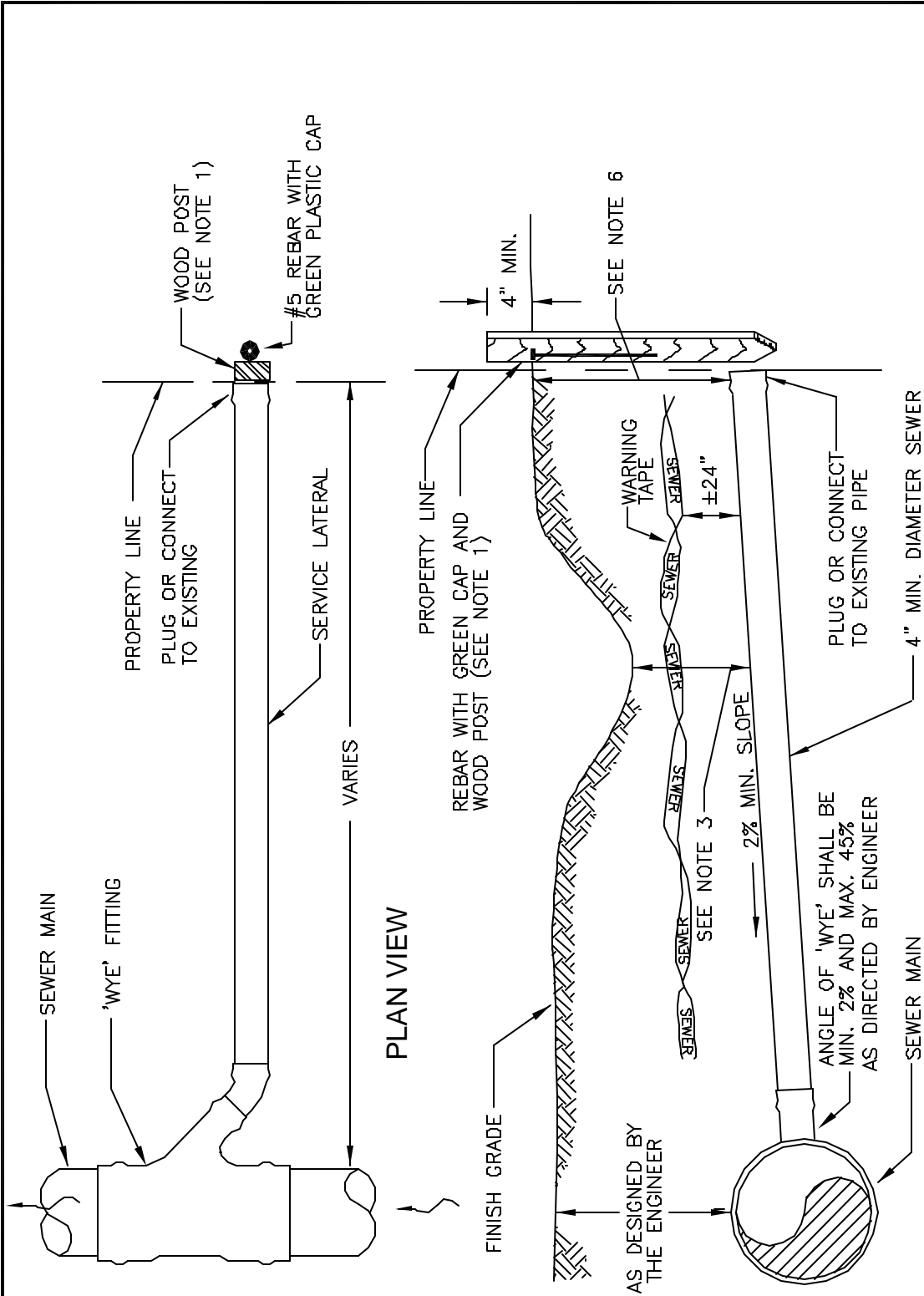

NOTES:

1. MARK SERVICE WITH GREEN PAINTED 2x4 POST OR STAMP "S" IN TOP OF CURB. POST SHALL EXTEND TO DEPTH OF SERVICE LATERAL. REBAR SHALL BE DRIVEN TO GROUND LEVEL.
2. ACCEPTABLE PIPE FOR USE WITHIN R.O.W. INCLUDES C900 PVC, SDR 35 PVC AND DUCTILE IRON.
3. MINIMUM CLEARANCE OF 18" REQUIRED BENEATH DITCH LINE. PIPE WITH LESS THAN 44" OF COVER SHALL BE INSULATED AS APPROVED BY THE ENGINEER.
4. DISTANCE FROM WYE TO MANHOLE AND THREE MEASURED DISTANCES FROM END OF SERVICE PIPE TO PERMANENT OBJECTS SHALL BE NOTED ON AS-BUILT PLANS.
5. SERVICE LATERAL SHALL END AT STAKE WITH A BELL END OF PIPE AND PLUG ASSEMBLY THAT WILL WITHSTAND TEST PRESSURES.
6. LATERAL DEPTH AT PROPERTY LINE SHALL ACCOMMODATE EXISTING BUILDING SEWER OR FUTURE BUILDING SITE(S).
7. PIPE CONNECTIONS IN THE RIGHT-OF-WAY THAT DO NOT USE BELL AND SPIGOT SHALL CONFORM TO STANDARD.



SCALE:
NTS
APPROVED:
RAR
REVISED:
11/29/02

SANITARY SEWER SERVICE CONNECTION

SECTION #
50.10
DETAIL #
50-11



SCALE:
NTS
APPROVED:
RAR
REVISED:
11/29/02

PRESSURE SANITARY SEWER SERVICE LATERAL

SECTION #
50.10

DETAIL #
50-12

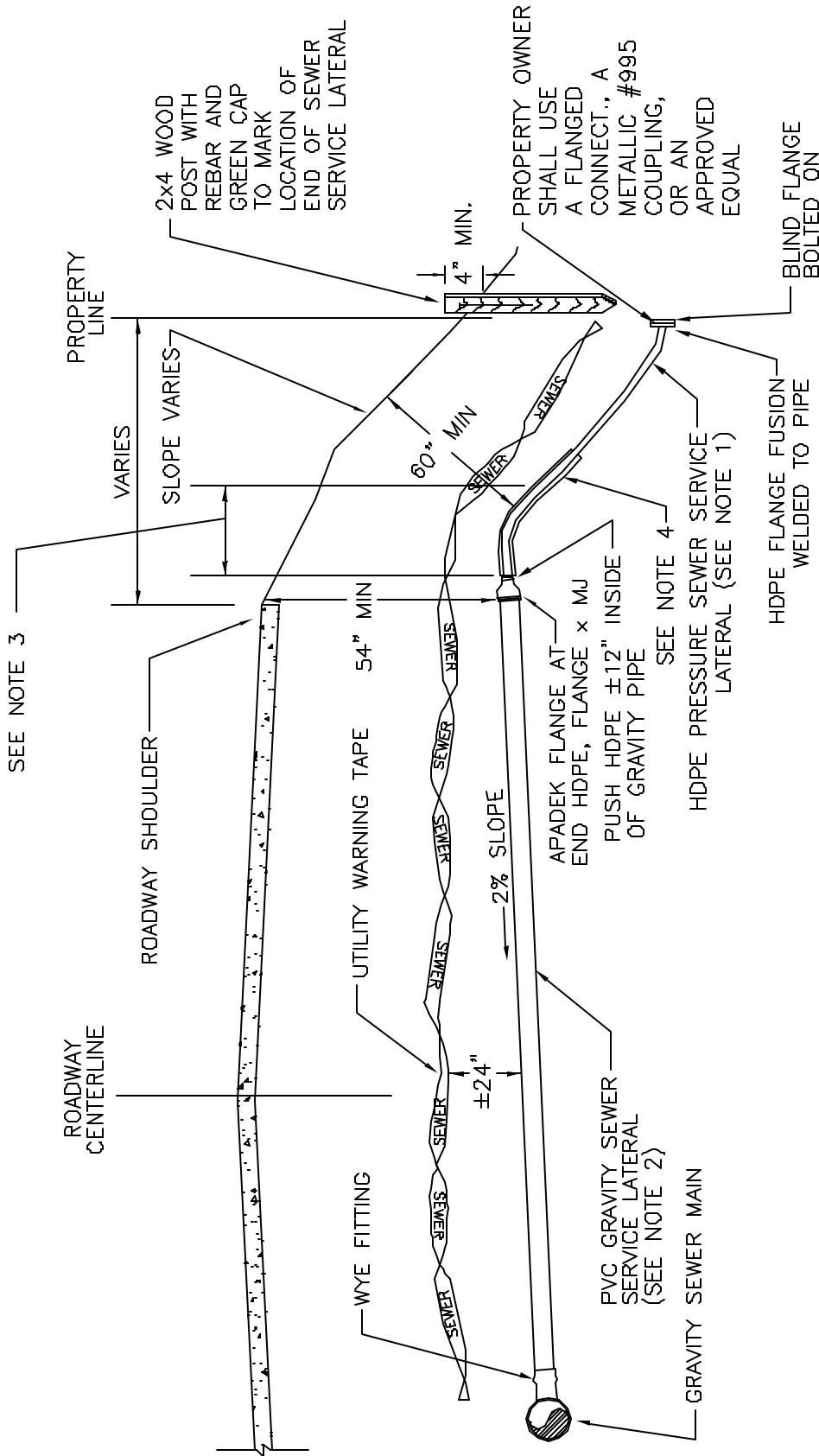

ELEVATION VIEW

NOTES:

1. HDPE PORTION OF SEWER SERVICE LATERAL SHALL BE CONTINUOUS AND SIZED PER LIFT STATION MANUFACTURER. LENGTH OF PIPE VARIES.
2. EXTEND PVC SEWER LATERAL TO EDGE OF SHOULDER.
3. USE MINIMUM DISTANCE TO BEND PIPE TO INCREASE DEPTH.
4. INSULATE PIPE WITH ONE SIX FOOT LENGTH OF IMCLOCK WRAPAROUND PIPE INSULATION OR AN APPROVED EQUAL.

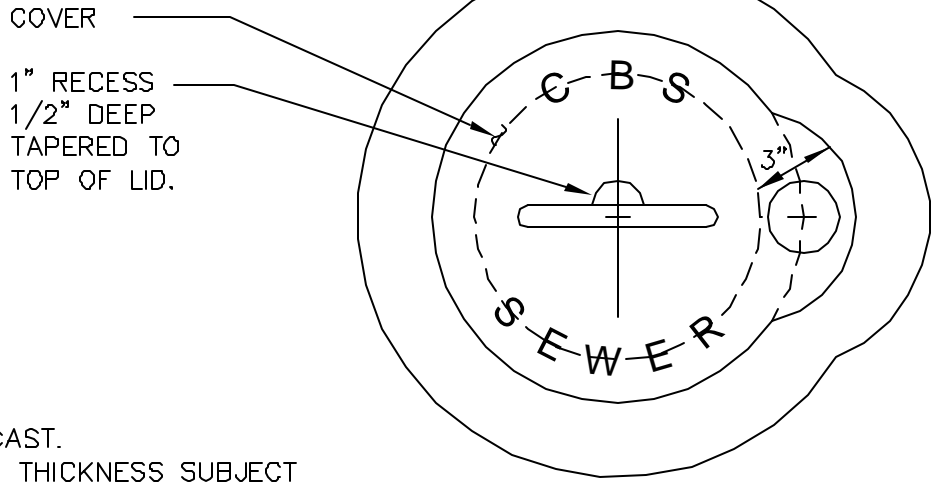

NOTES:

1. TO BE CAST.
2. CASTING THICKNESS SUBJECT TO FOUNDRY REQUIREMENTS.
3. CASTING MUST BE SIZED TO 8" AND OVER, CLASS 50 D.I.P.
4. COVER SHALL BE 1/4" BELOW TOP OF PAVEMENT & 6" BELOW GRAVEL.

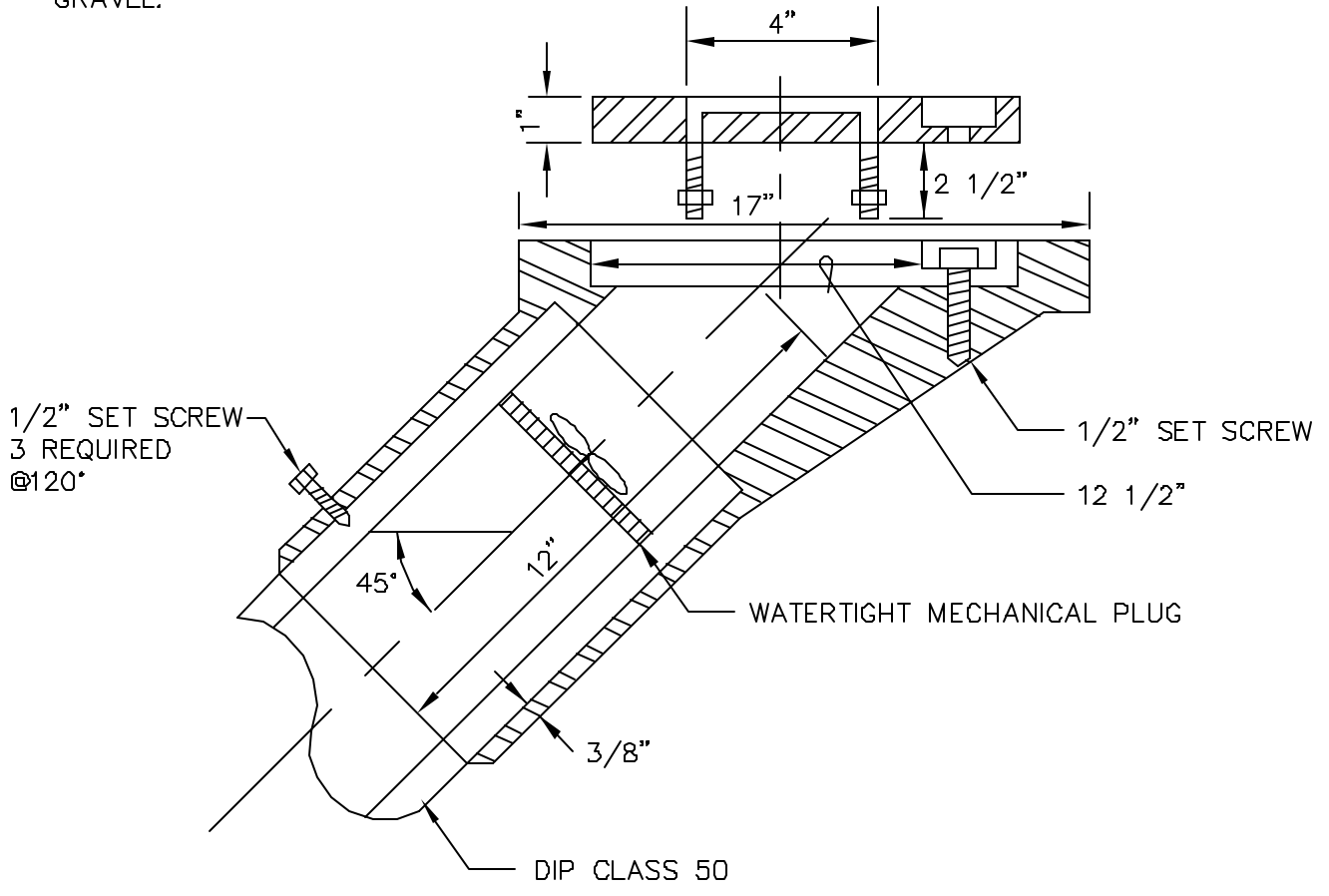

SCALE:
NTS
APPROVED:
RAR
REVISED:
11/29/02

SANITARY CLEANOUT COVER

SECTION #
50.12
DETAIL #
50-13

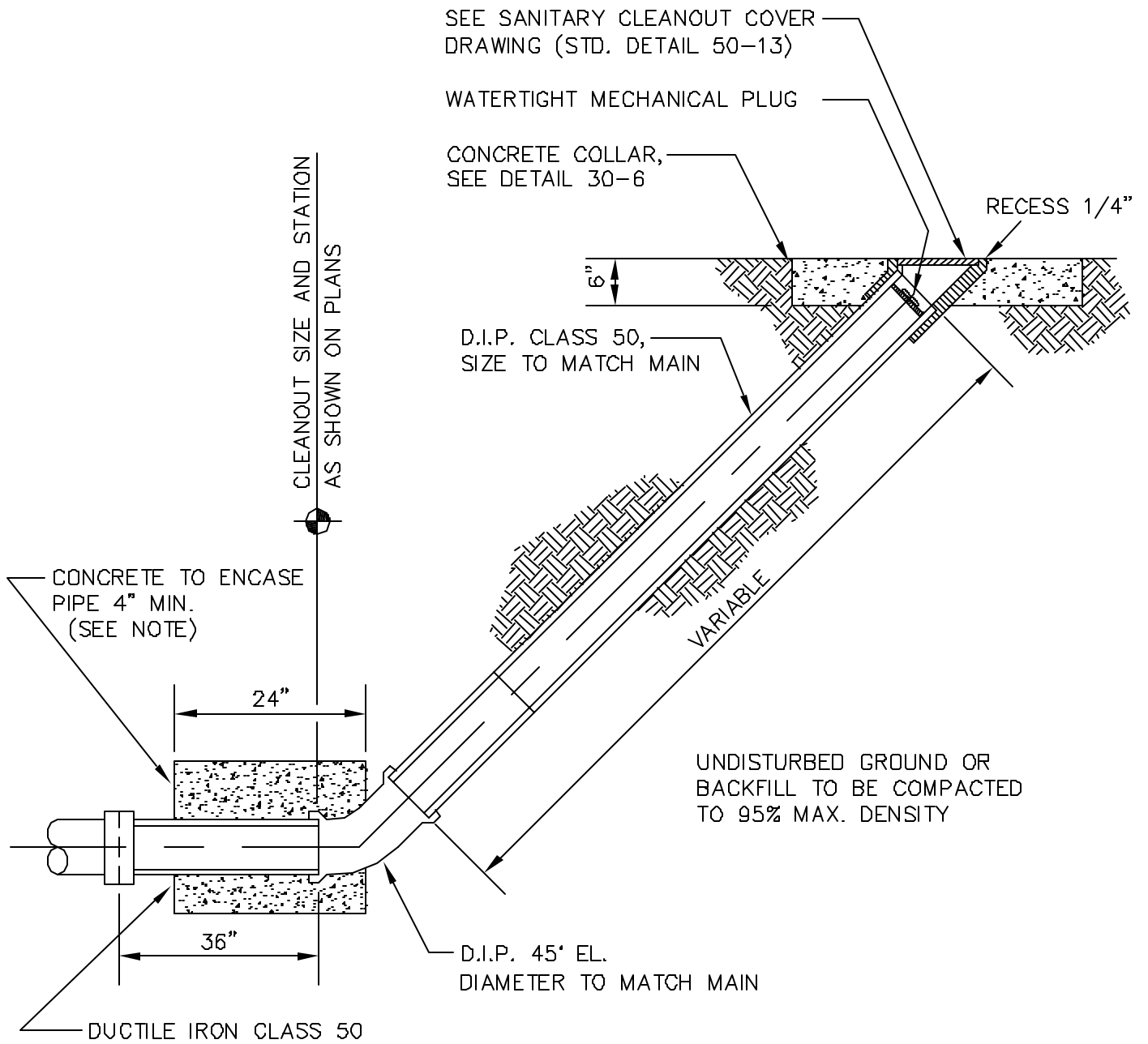

NOTE:

WHEN D.I. PIPE WITH MECHANICAL JOINT IS USED, CONCRETE ENCASEMENT IS NOT NECESSARY



SCALE:
NTS
APPROVED:
RAR
REVISED:
11/29/02

SANITARY CLEANOUT

SECTION#
50.12
DETAIL #
50-14

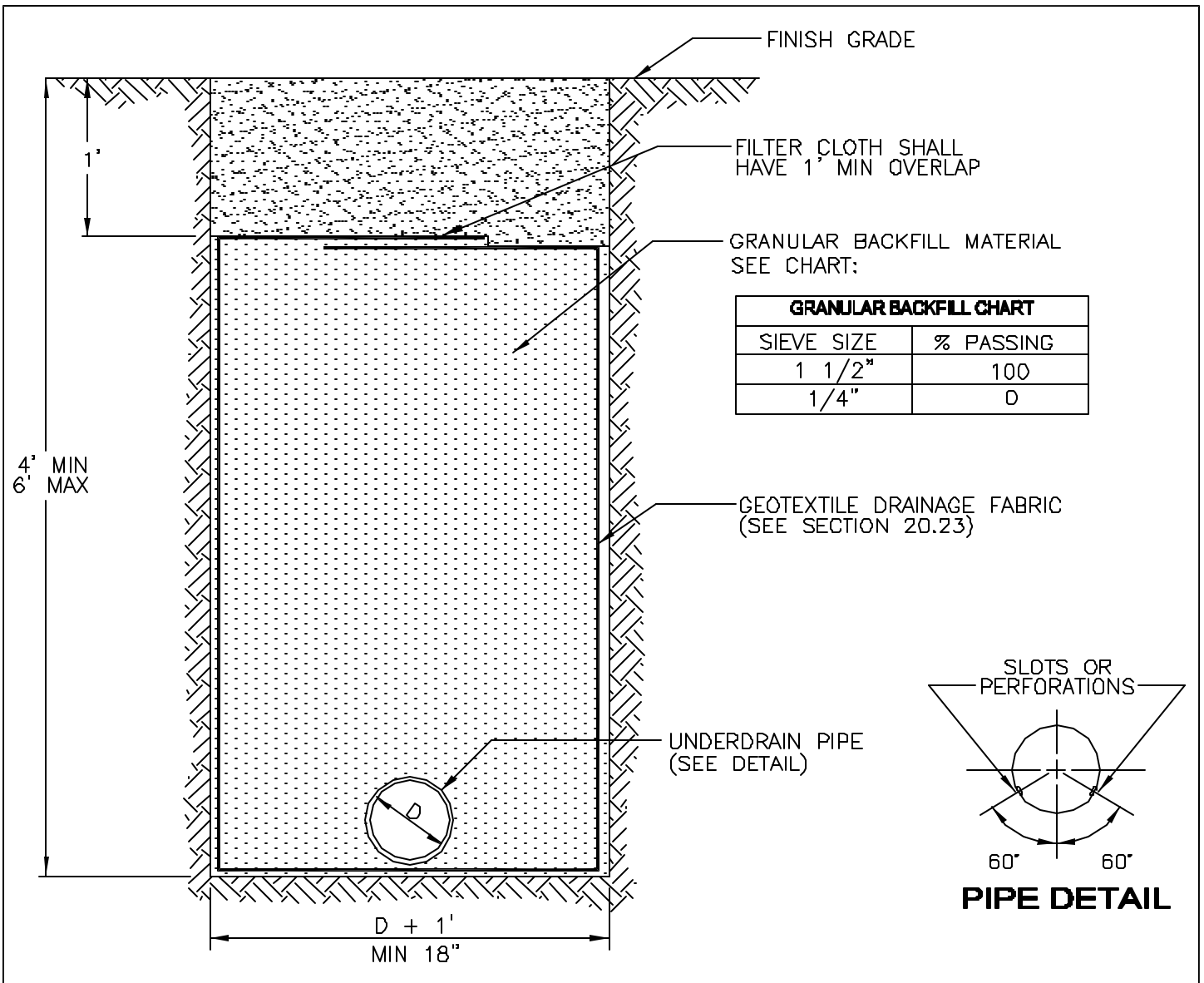

NOTES:

1. WHEN TRENCH IS UNDER A ROADBED, PAVED DITCH, OR OTHER STRUCTURE, THE GRANULAR BACKFILL MATERIAL, AND FILTER CLOTH SHALL COMPLETELY FILL THE TRENCH.
2. THE OUTFALL END OF THE PIPE SHALL BE COVERED WITH GALVANIZED NO. 17 GAGE HARDWARE CLOTH SCREEN WITH 1/2" x 1/2" MESH OPENINGS. THE SCREEN SHALL CLAMPED ON WITH A STAINLESS STEEL CLAMP. THE UPGRADE END OF THE UNDERDRAIN SHALL COMMENCE WITH A CLEANOUT.
3. UNLESS OTHERWISE SHOWN ON PLANS, UNDERDRAIN SHALL BE INSTALLED UNDER THE ROADWAY DITCH.
4. NON-PERFORATED PIPE MAY BE USED AT THE OUTLET ENDS OF UNDERDRAINS AS APPROVED BY THE ENGINEER.
5. EXCEPT WHERE THE UNDERDRAIN OUTLETS INTO A PIPE CULVERT, THE OUTLET END OF THE UNDERDRAIN SHALL BE MARKED WITH A SUITABLE MARKER APPROVED BY THE ENGINEER.
6. STRIP UNDERDRAIN MAY BE SUBSTITUTED AS APPROVED BY THE ENGINEER.



SCALE:
NTS
APPROVED:
RAR
REVISED:
11/29/02

UNDERDRAIN

SECTION#
55.03

DETAIL #
55-1

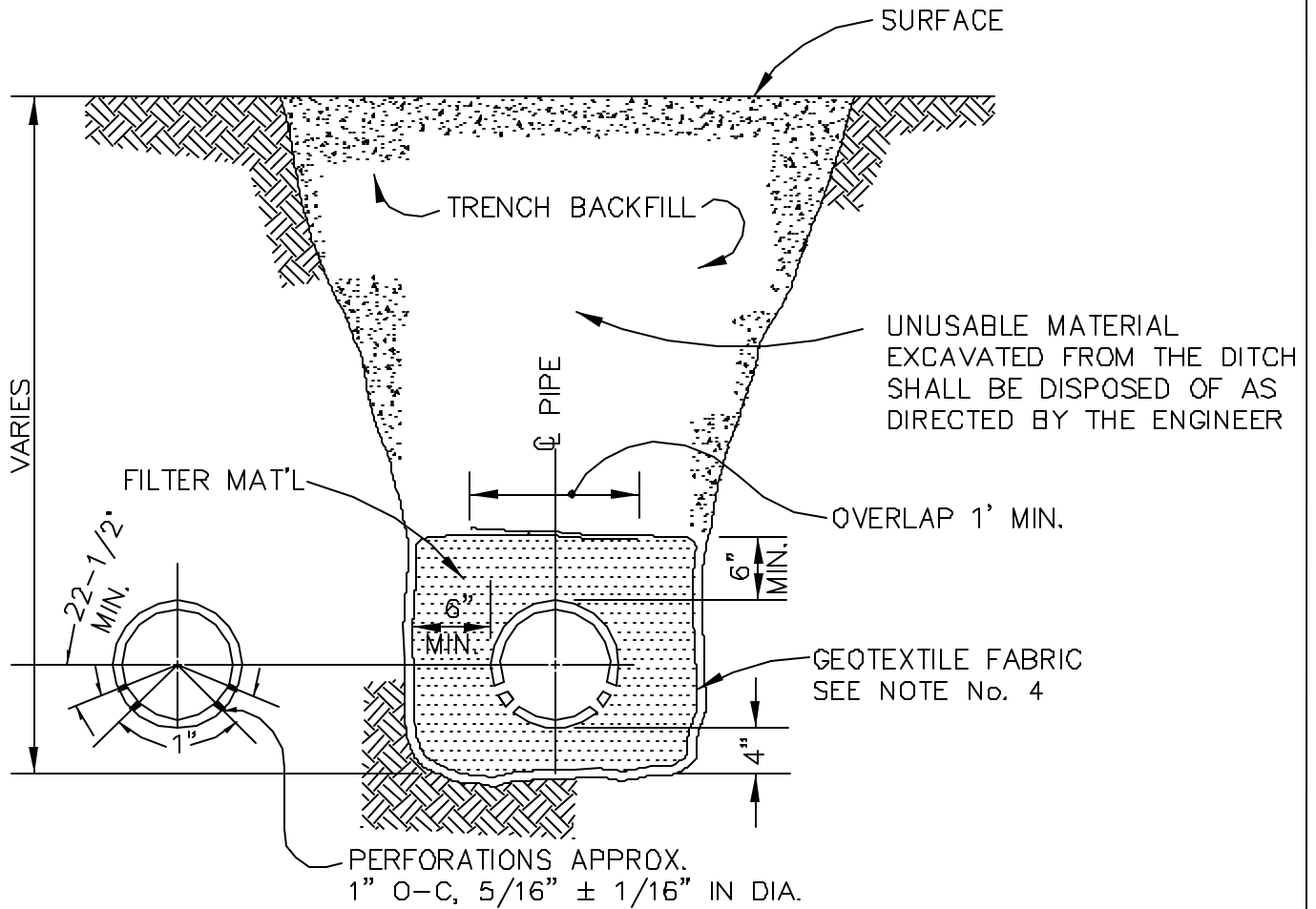

NOTES:

1. FILTER MATERIAL TYPE SHALL BE AS SPECIFIED IN THE BID PROPOSAL.
2. COMPACTION IN PUBLIC RIGHTS-OF-WAY UNDER THE EXISTING OR PROPOSED ROAD PRISM SHALL BE 95% OF MAXIMUM DENSITY, UNLESS OTHERWISE SPECIFIED OR DIRECTED BY THE ENGINEER.
3. TRENCH BACKFILL SHALL BE CLASSIFIED BACKFILL AS CALLED FOR IN THE BID PROPOSAL.
4. GEOTEXTILE FABRIC SHALL BE A NON-WOVEN MATERIAL AS PER THE SPECIFICATIONS UNLESS OTHERWISE SPECIFIED.



SCALE:
NTS
APPROVED:
RAR
REVISED:
11/29/02

SUBDRAIN

SECTION #
55.03

DETAIL #
55-2

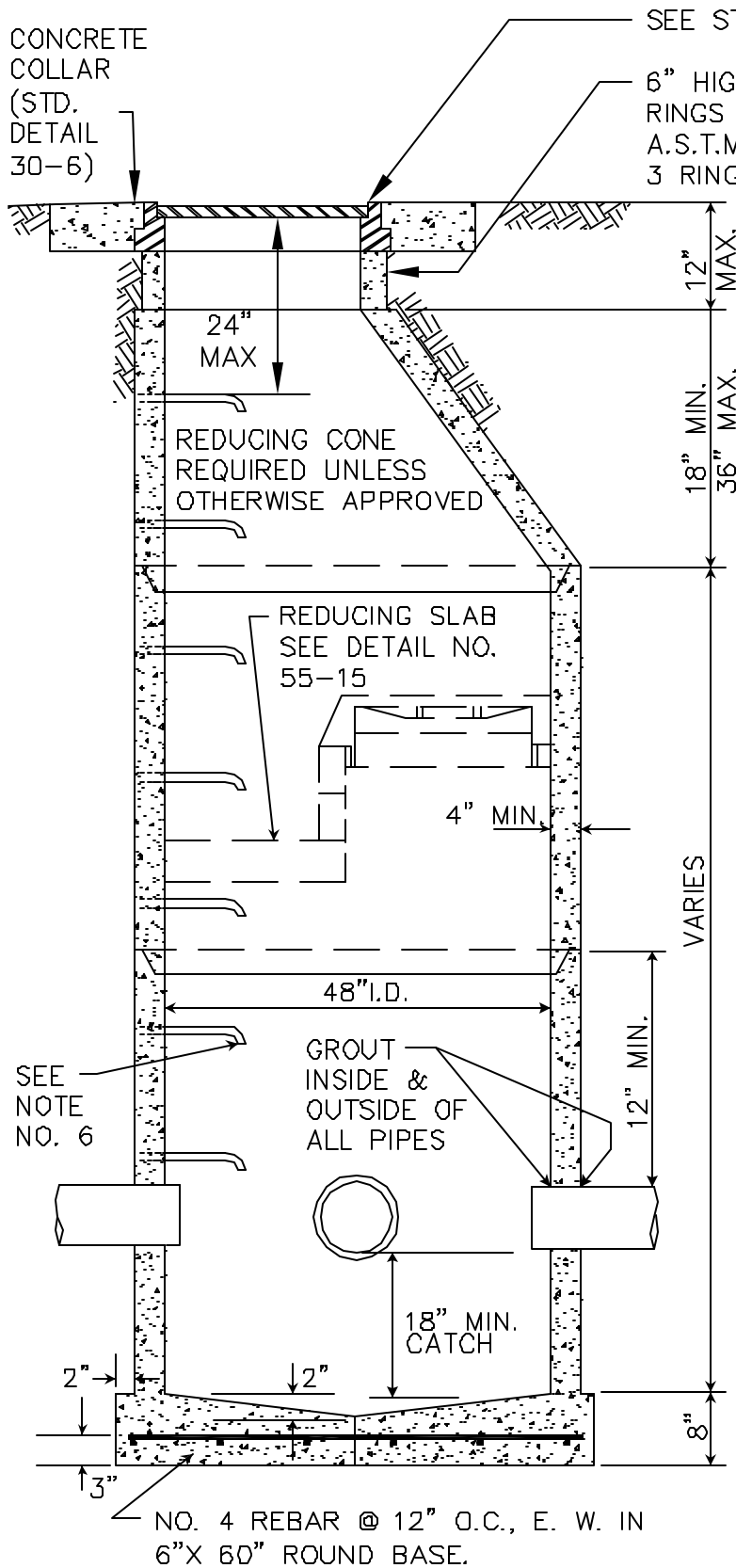

SEE STD. DETAIL 55-7
 6" HIGH PRECAST CONC. RINGS REQ'D SHALL MEET A.S.T.M. C-478-64T 3 RINGS MAX.

- NOTES:
1. REFER TO A.S.T.M. DESIGNATION C-470-69 FOR DESIGN REQUIREMENTS.
 2. SEE MANHOLE FRAME & COVER DETAIL NO. 55-6b & 55-6c.
 3. MIN. STEEL REQ'D FOR BARREL AS PER A.S.T.M. C-478-69 SHALL BE EMBEDDED IN BASE SO THAT FIRST BARREL SECTION IS CONNECTED WITH BASE.
 4. PRIMARY LEADS NOT TO EXCEED 30" CPP-S WITH INCLUDED ANGLE BETWEEN LEADS NO LESS THAN 135° OR PRIMARY LEAD NOT TO EXCEED 24" CPP-S WITH INCLUDED ANGLE LESS THAN 135°.
 5. BLOCKOUTS TO BE FORMED.
 6. RUNGS TO BE PLACED 12" ON CENTER ON UNOBSTRUCTED SIDE OF MANHOLE 18" MAX. FROM BOTTOM OF MANHOLE & 6" MAX. FROM TOP OF CONE. IF UNOBSTRUCTED SIDE NOT AVAILABLE, BOTTOM RUNG TO BE PLACED 6" OVER SMALLEST PIPE. SEE RUNG (MANHOLE STEP) DETAIL NO. 55-5.



SCALE:
 NTS
 APPROVED:
 RAR
 REVISED:
 11/29/02

STORM DRAIN MANHOLE TYPE I

SECTION#
 55.04
 DETAIL #
 55-3

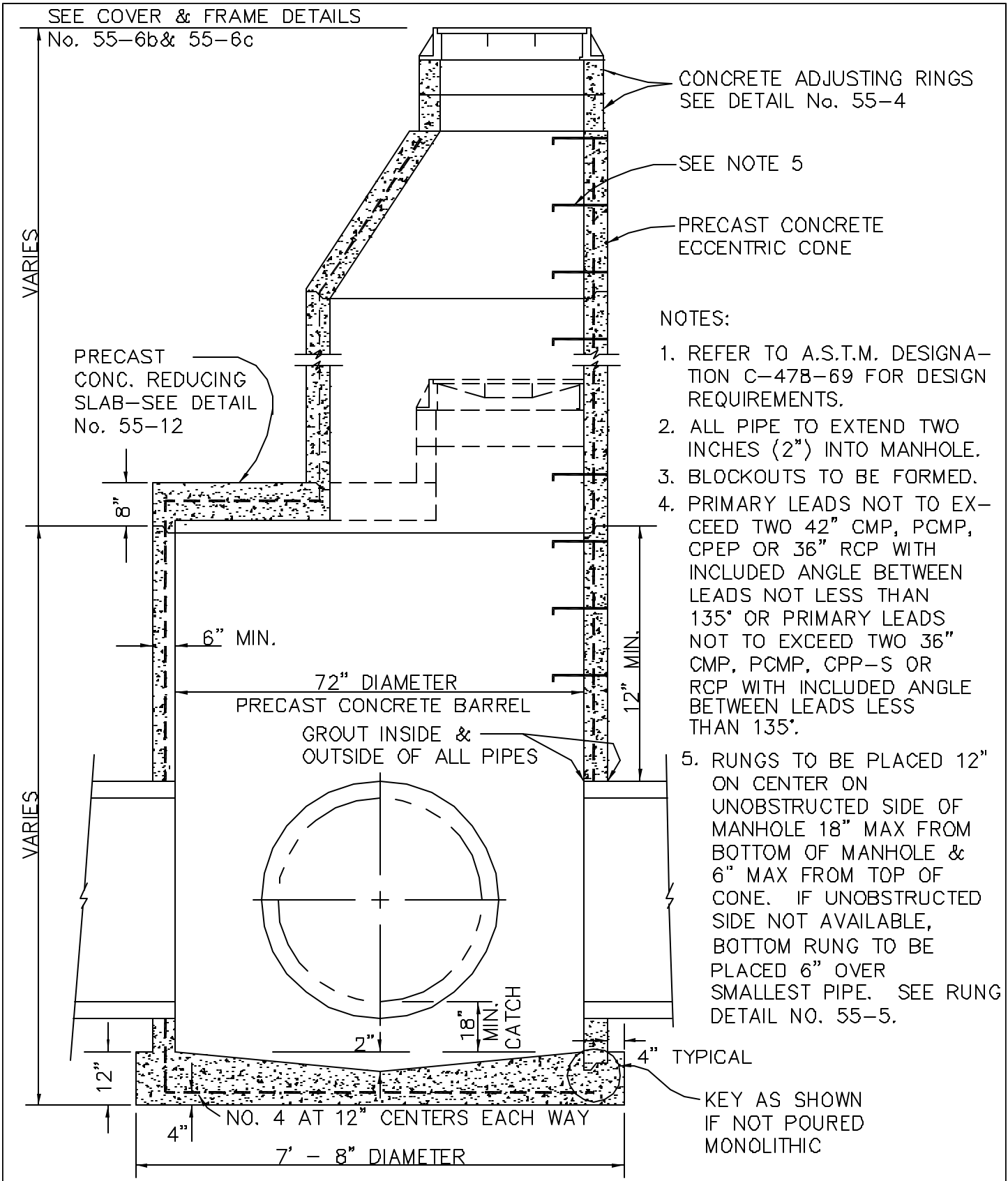

- NOTES:
1. REFER TO A.S.T.M. DESIGNATION C-478-69 FOR DESIGN REQUIREMENTS.
 2. ALL PIPE TO EXTEND TWO INCHES (2") INTO MANHOLE.
 3. BLOCKOUTS TO BE FORMED.
 4. PRIMARY LEADS NOT TO EXCEED TWO 42" CMP, PCMP, CPEP OR 36" RCP WITH INCLUDED ANGLE BETWEEN LEADS NOT LESS THAN 135° OR PRIMARY LEADS NOT TO EXCEED TWO 36" CMP, PCMP, CPP-S OR RCP WITH INCLUDED ANGLE BETWEEN LEADS LESS THAN 135°.
 5. RUNGS TO BE PLACED 12" ON CENTER ON UNOBSTRUCTED SIDE OF MANHOLE 18" MAX FROM BOTTOM OF MANHOLE & 6" MAX FROM TOP OF CONE. IF UNOBSTRUCTED SIDE NOT AVAILABLE, BOTTOM RUNG TO BE PLACED 6" OVER SMALLEST PIPE. SEE RUNG DETAIL NO. 55-5.



SCALE:
NTS
APPROVED:
RAR
REVISED:
11/29/02

STORM DRAIN MANHOLE TYPE II

SECTION #
55.04

DETAIL #
55-4

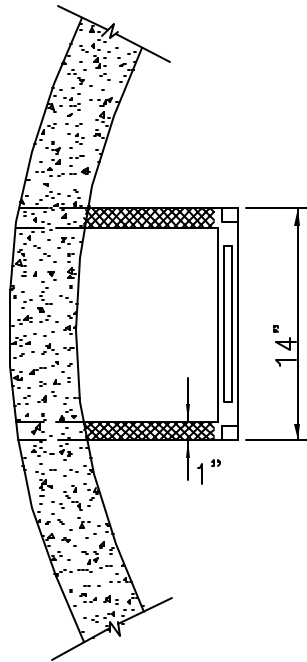

NOTE:
 STEPS SHALL BE LANE POLYETHYLENE 14"
 LADDER STEPS, OR APPROVED EQUAL.
 STEPS SHALL BE INSTALLED IN
 ACCORDANCE WITH MANHOLE STEP
 MANUFACTURER'S RECOMMENDATIONS.

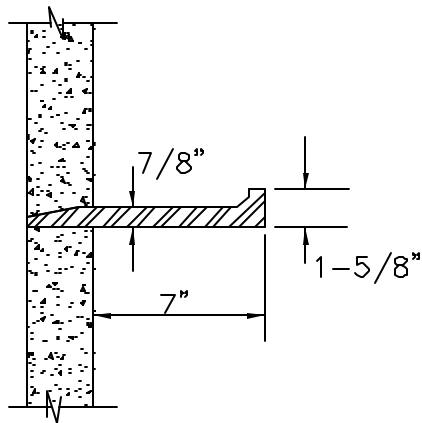

SCALE:
 NTS
 APPROVED:
 RAR
 REVISED:
 11/29/02

MANHOLE STEP

SECTION #
 55.04

DETAIL #
 55-5

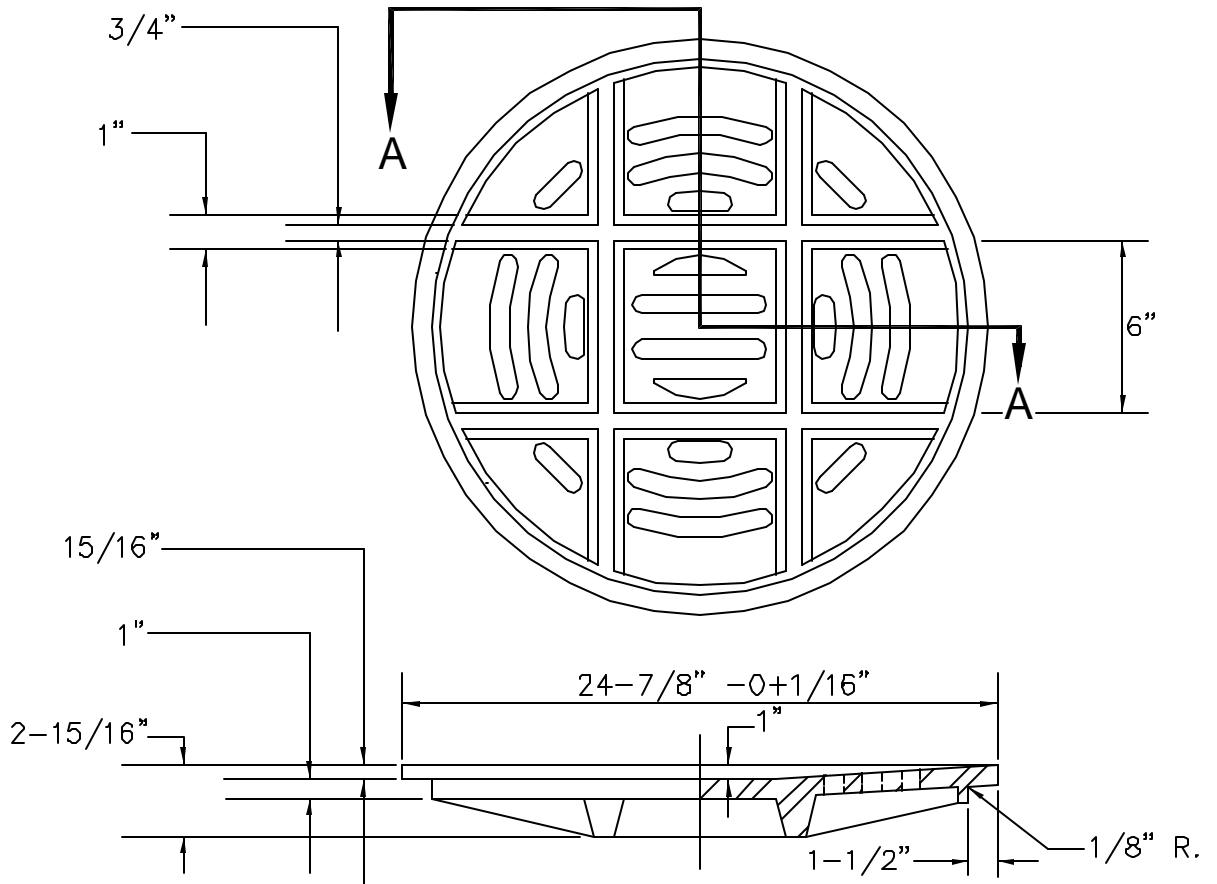

SECTION A-A

STRENGTH REQUIREMENT FOR
 TRANSVERSE BREAKING LOAD
 SHALL BE 2000 P.S.I. PER
 A.S.T.M. A-438

NOTES:

1. FRAME AND GRATE SHALL BE DUCTILE IRON.
2. FRAME AND GRATE SHALL BE OF A TYPE THAT WILL NOT CREATE A HAZARD FOR PEDESTRIANS OR BICYCLE TRAFFIC.
3. FRAME AND GRATE SHALL MEET OR EXCEED H-20 LOADING REQUIREMENTS.

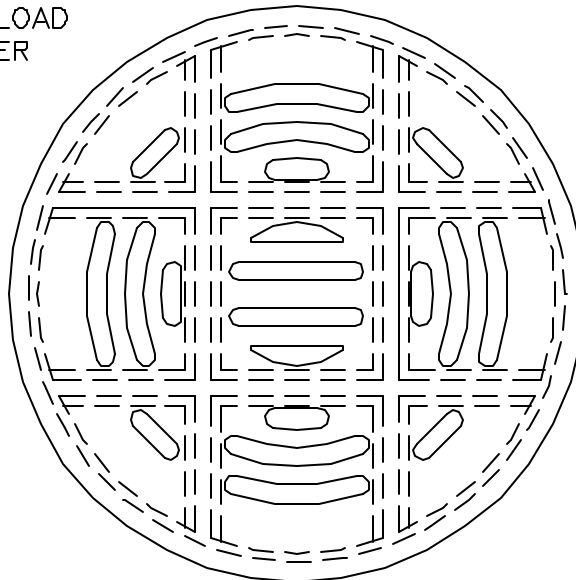

SCALE:
 NTS
 APPROVED:
 RAR
 REVISED:
 11/29/02

**TOP INTAKE
 USE WITH STANDARD GRADE RING**

SECTION #
 55.04

DETAIL #
 55-6

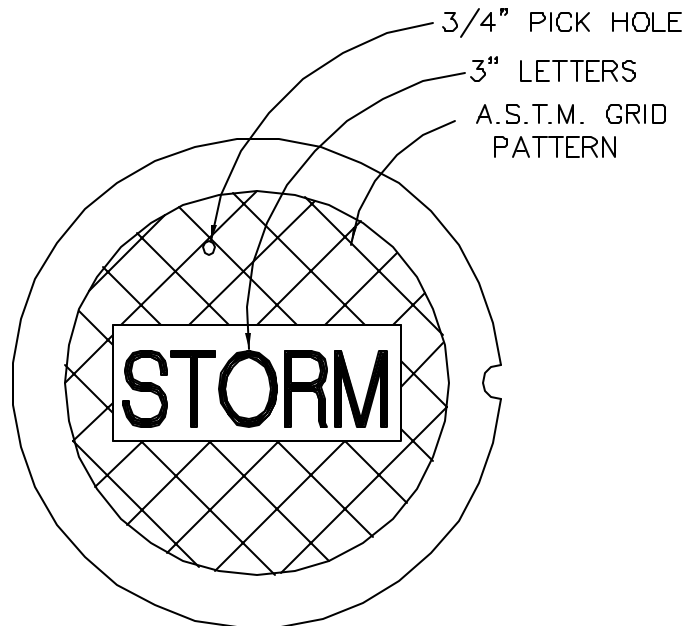
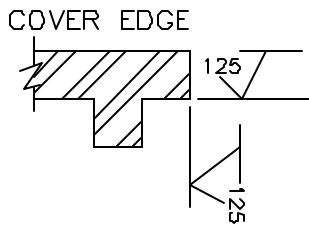
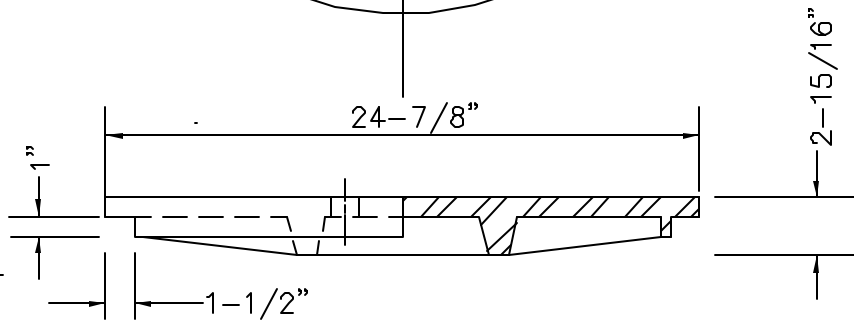
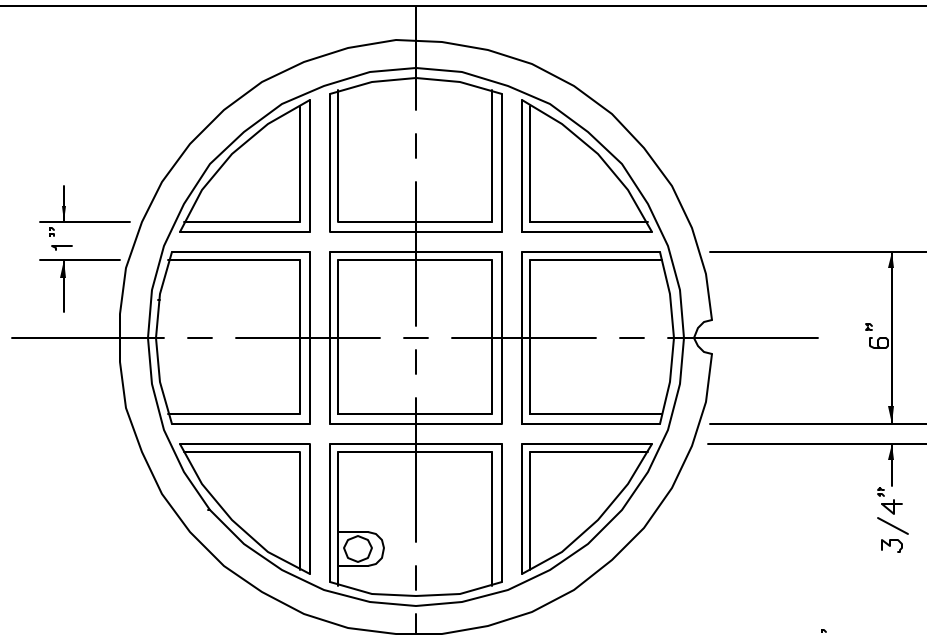

SCALE:
NTS
APPROVED:
RAR
REVISED:
11/29/02

**MANHOLE COVER
SOLID LID**

SECTION #
55.05

DETAIL #
55-6b

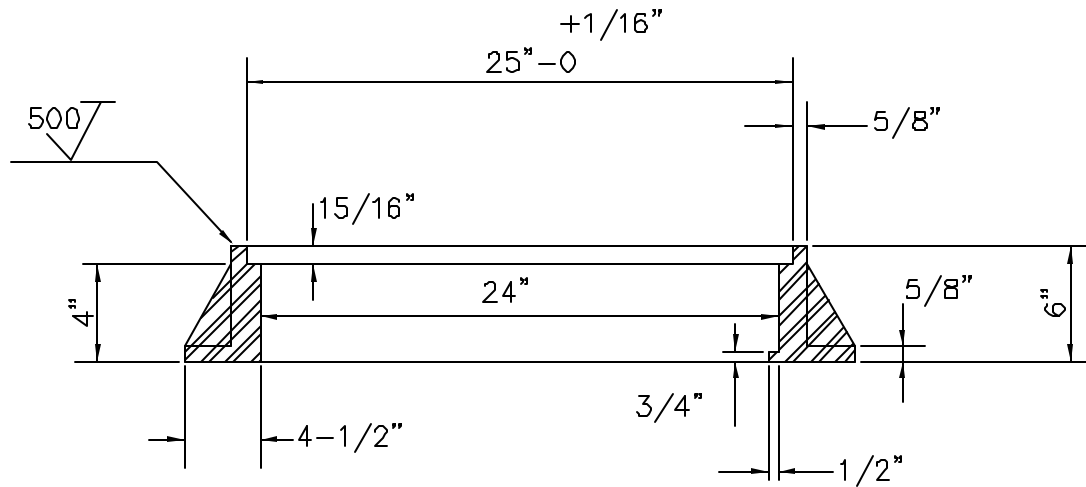
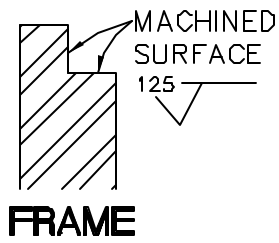
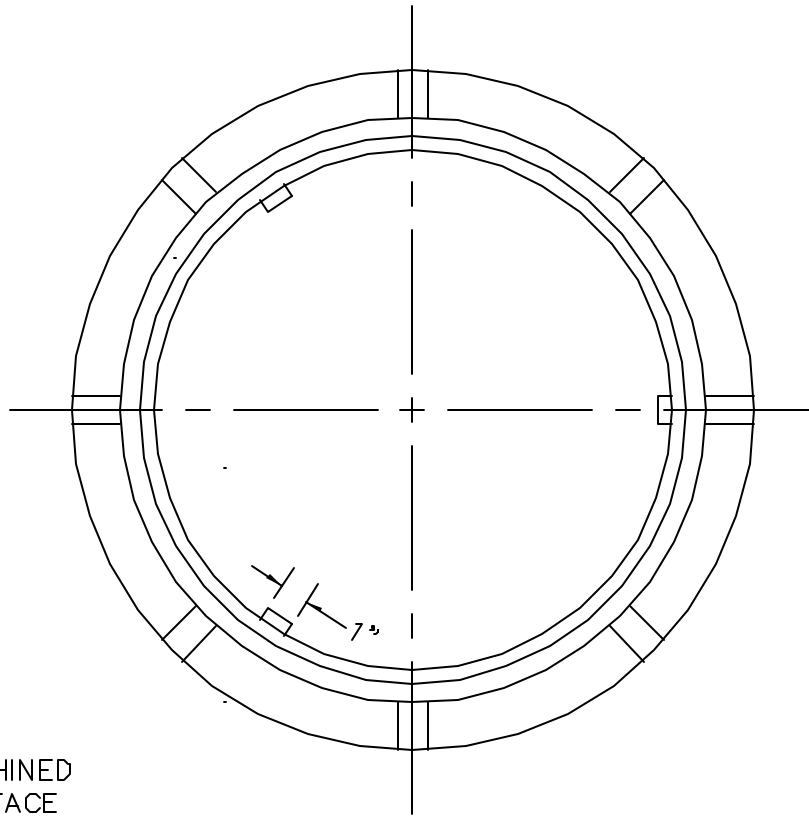

SCALE:
NTS
APPROVED:
RAR
REVISED:
11/29/02

MANHOLE FRAME

SECTION #
55.05

DETAIL #
55-6c

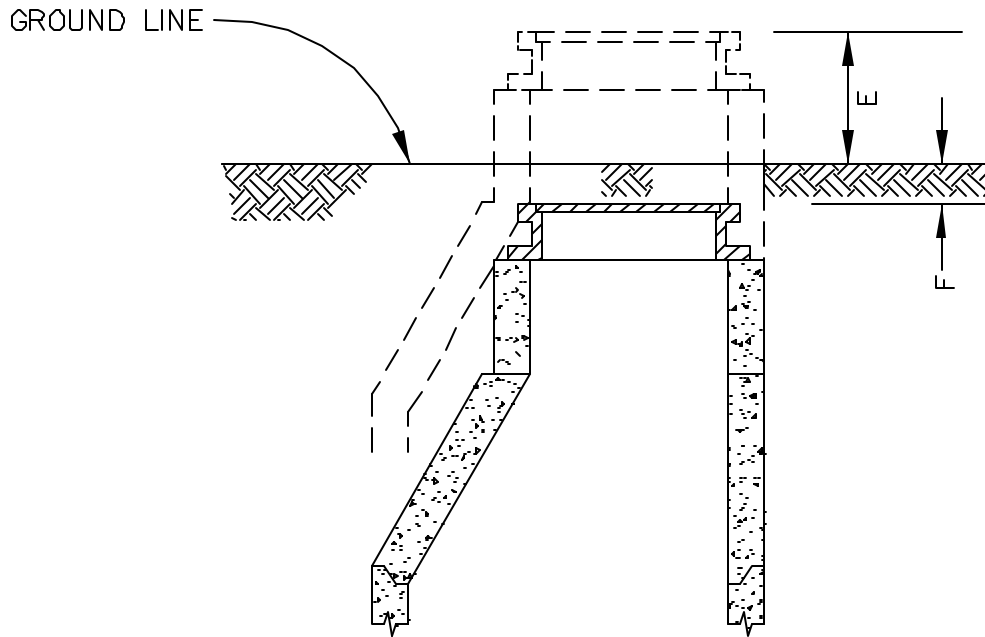

LOCATION	E	F
BACKYARDS, GRAVEL STREETS, AND ALLEY AREAS WHERE TRAVELED.		6"
UNDEVELOPED AND SWAMPY AREAS.	24" MIN	
HIGHWAY R.O.W.'S OUTSIDE TRAFFIC AREAS.	6"	
PAVED STREETS.		1/4"



SCALE:
NTS
APPROVED:
RAR
REVISED:
11/29/02

MANHOLE HEIGHTS

SECTION #
55.04

DETAIL #
55-7

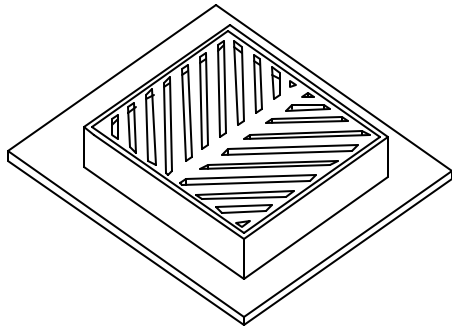

FRAME AND GRATE

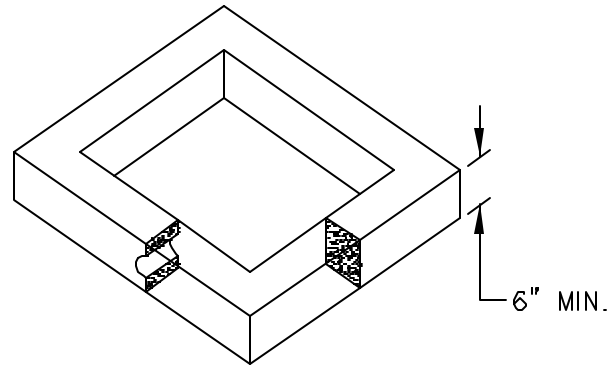

CONCRETE SECTION

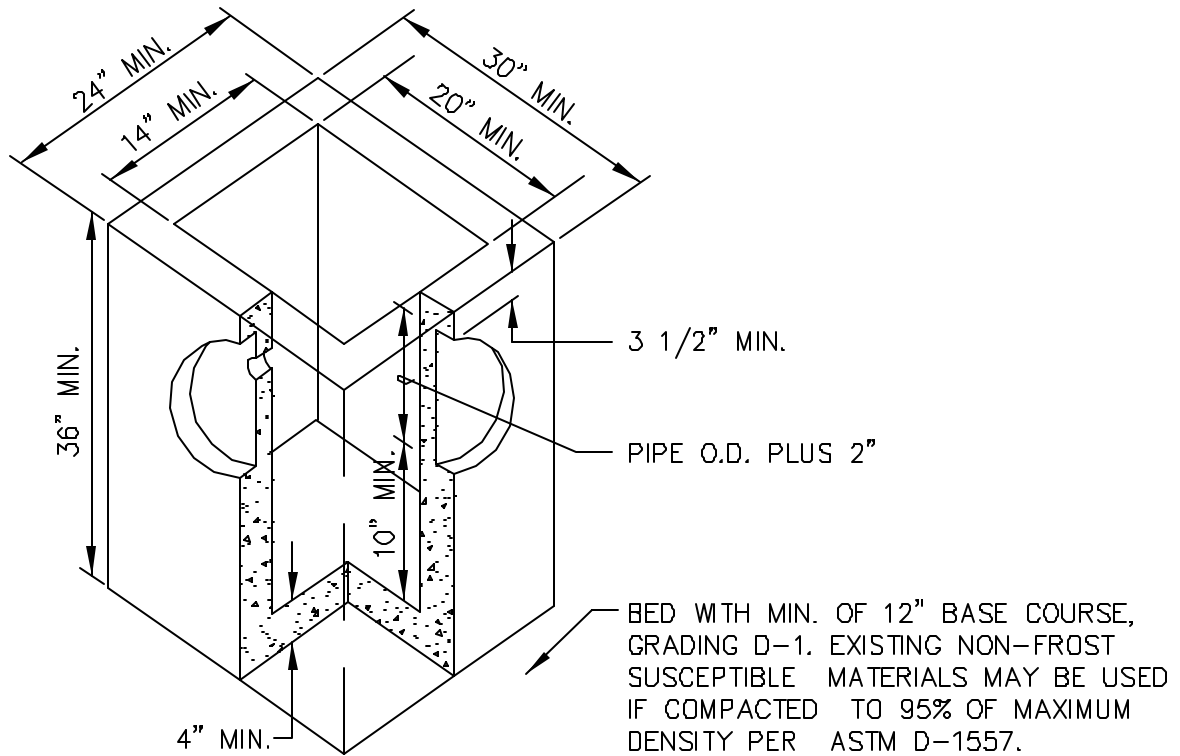

CATCH BASIN

NOTES:

1. FOR USE WITH TWO INLET/OUTLET PIPES OF 12" DIAMETER OR SMALLER. FOR LARGER AND/OR MORE INLET/OUTLET PIPES, OR IF CATCH BASIN IS DEEPER THAN 4', INSTALL A TYPE I OR TYPE II STORM DRAIN MANHOLE (SEE CBS DETAILS 55-3 & 55-4).
2. ENTIRE KNOCKOUT IS TO BE REMOVED AND SEALED SHUT AROUND PIPE. ALL PIPES ARE TO EXTEND 1" MIN. AND 2" MAX. INTO CATCH BASIN. GROUT INTERIOR AND EXTERIOR BETWEEN FRAME, SECTIONS, AND CATCH BASIN.
3. FRAME AND GRATE SHALL BE DUCTILE IRON. FRAME MAY BE CAST INTO THE TOP UNIT OR PLACED OVER THE OPENING AS APPROVED BY THE ENGINEER. FRAME AND GRATE MUST BE OF A TYPE THAT WILL NOT CREATE A HAZARD FOR BICYCLE TRAFFIC.
4. CATCH BASIN SHALL MEET HIGHWAY STANDARD-20 LOAD REQUIREMENTS.
5. MINIMUM STEEL SHALL BE SPECIFIED BY ASTM C-478-69.



SCALE:
NTS
APPROVED:
RAR
REVISED:
11/29/02

PRECAST CATCH BASIN,
TYPE I

SECTION #
55.04

DETAIL #
55-8

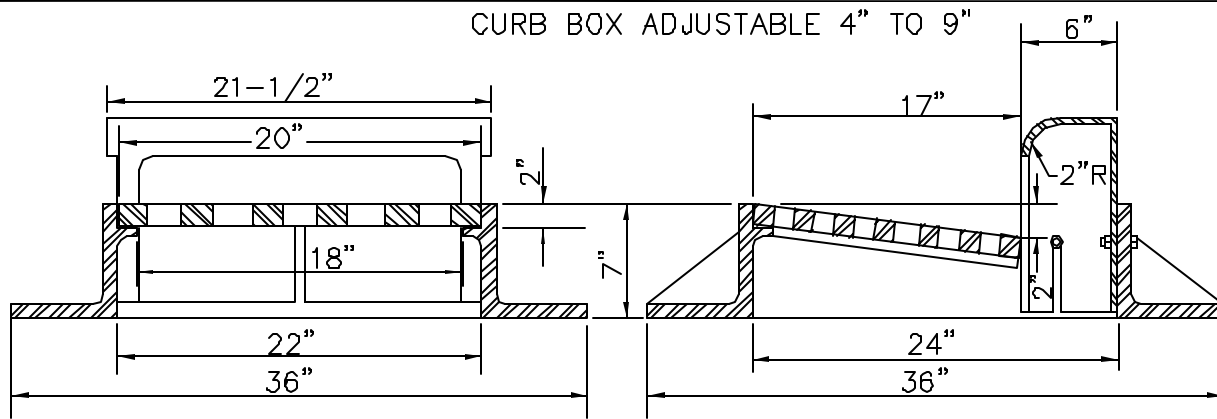

CURB INLET FRAME, GRATE AND CURB BOX

ILLUSTRATING NEENAH R-3065 WITH TYPE DR REVERSIBLE GRATE. FOR OPPOSITE HAND FLIP GRATE TOP TO BOTTOM.

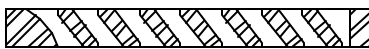
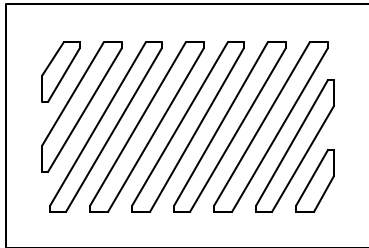

ALTERNATE TYPE L GRATE

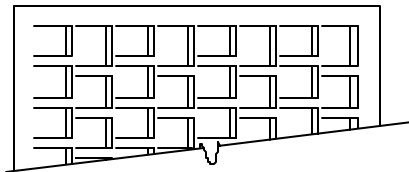

ALTERNATE TYPE V GRATE

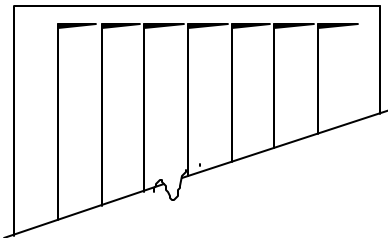

NOTES:

1. FRAME AND GRATE SHALL BE DUCTILE IRON AND SHALL BE IFCO 571 OR AN APPROVED EQUAL.
2. GRATE SHALL HAVE 1" DIAGONAL BARS WITH 1 1/2" OPENINGS.
3. FRAME AND GRATE SHALL BE OF A TYPE THAT WILL NOT CREATE A HAZARD FOR BICYCLE TRAFFIC.
4. INSTALL RIGHT OR LEFT GRATES FOR BICYCLE SAFETY AS DETERMINED BY THE ENGINEER.



SCALE:
NTS
APPROVED:
RAR
REVISED:
11/29/02

**CATCH BASIN INLET
FOR TYPE I CURB & GUTTER**

SECTION #
55.04

DETAIL #
55-9

NEENAH No. R-3065 CURB INLET FRAME & CURB BOX WITH TYPE DR, L, OR V GRATE (SEE DETAIL 55-9) OR APPROVED EQUAL.

MATCH BACK OF CURB

2-6" HIGH PRECAST CONC. RING SHALL MEET A.S.T.M. C-478-64T

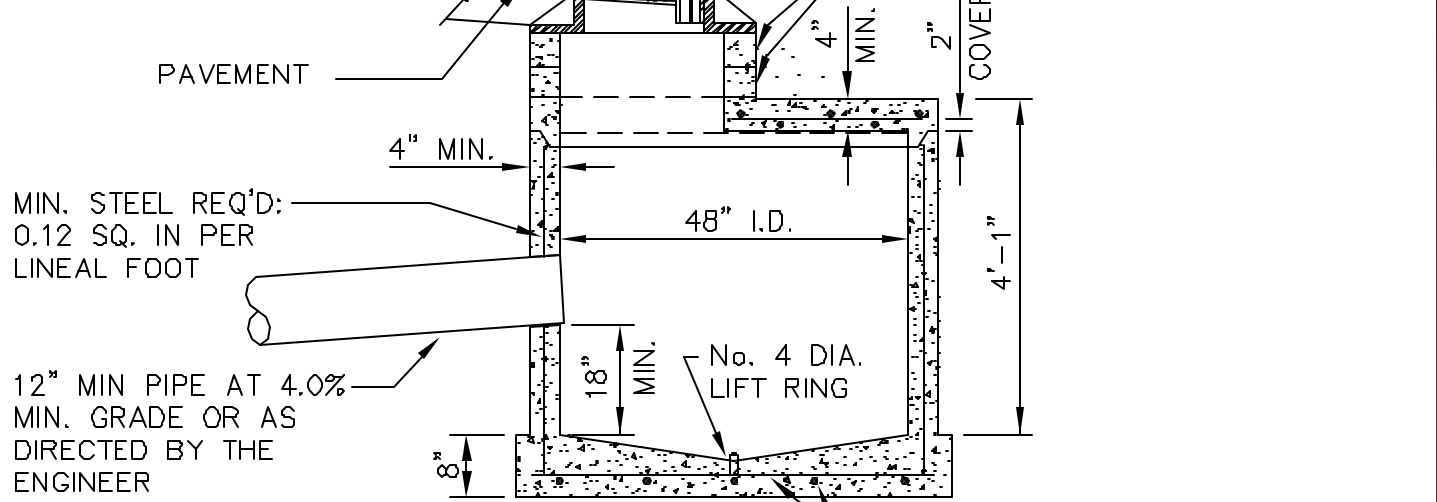

SIDE VIEW

MIN. STEEL REQ'D:
0.12 SQ. IN PER
LINEAL FOOT

12" MIN PIPE AT 4.0%
MIN. GRADE OR AS
DIRECTED BY THE
ENGINEER

#4 REBAR AT 12" INTERVALS
BOTH WAYS

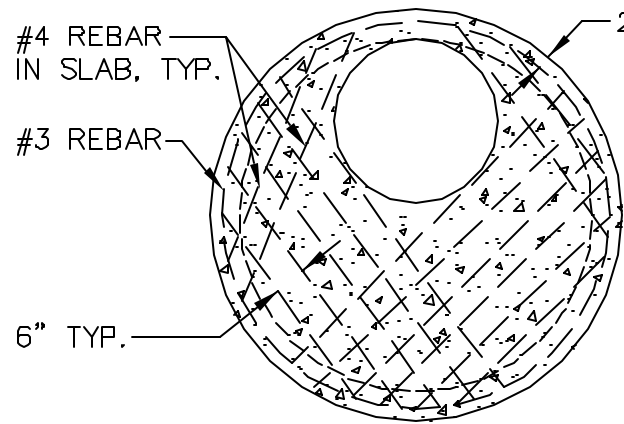

REDUCING SLAB

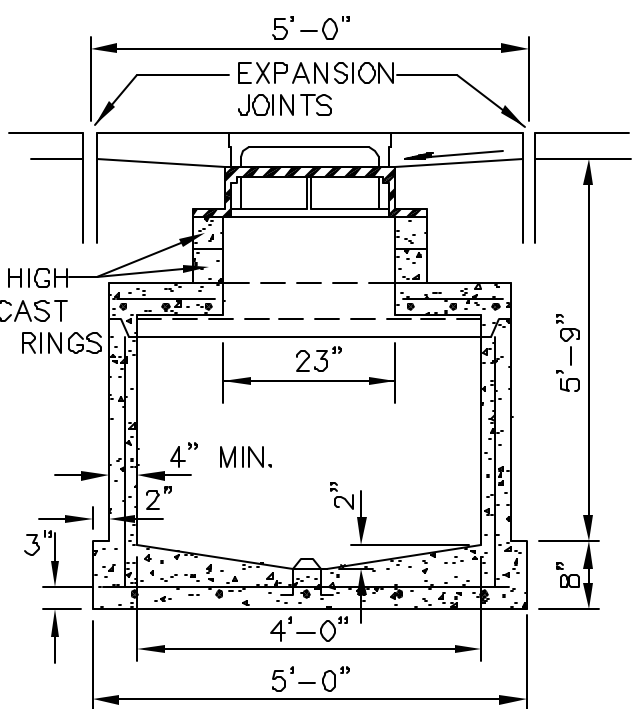

FRONT VIEW

NOTES:

1. COMPRESSIVE STRENGTH OF CONC. SHALL BE MINIMUM 4000 P.S.I. EXCEPT BASE SLAB WHICH MAY BE 3000 P.S.I. BASE & BARREL SHALL BE CONNECTED BY CONTINUOUS STEEL.
2. SEE ASTM C-478-64T FOR DESIGN REQUIREMENTS.
3. AT CATCH BASIN, DELETE CONC. CURB AND GUTTER, PAVE TO FACE OF CATCH BASIN INLET.



SCALE:
NTS
APPROVED:
RAR
REVISED:
11/29/02

**PRECAST CATCH BASIN
FOR TYPE II CURB & GUTTER**

SECTION #
55.04
DETAIL #
55-10

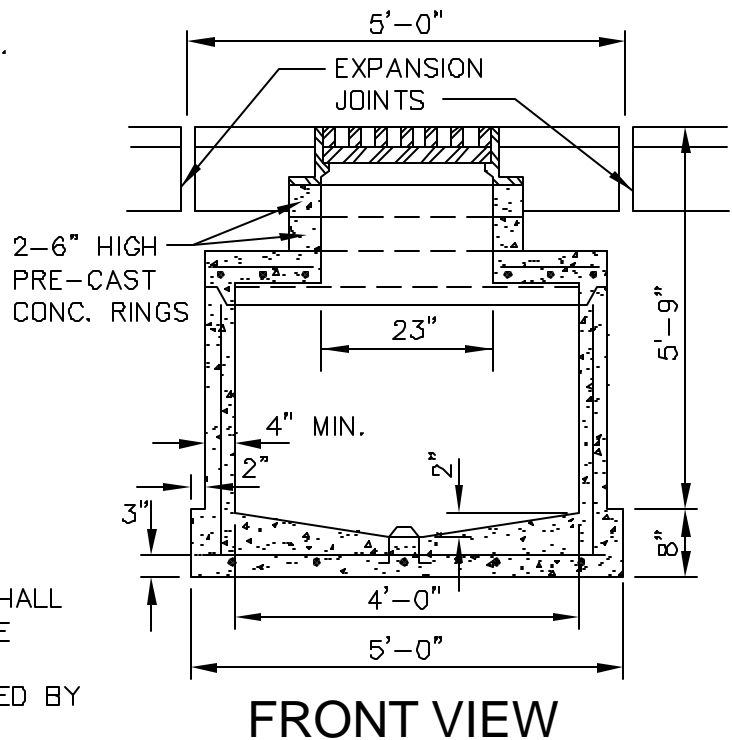
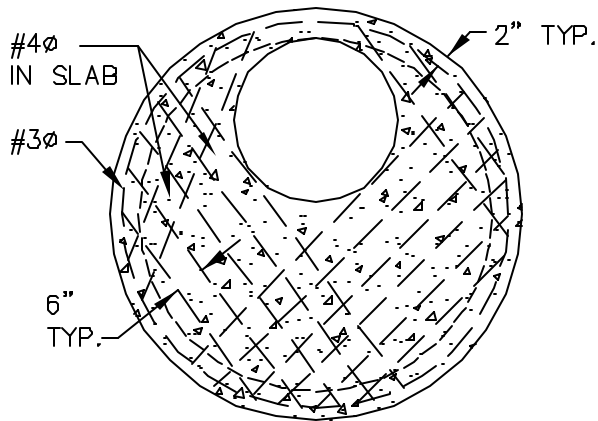
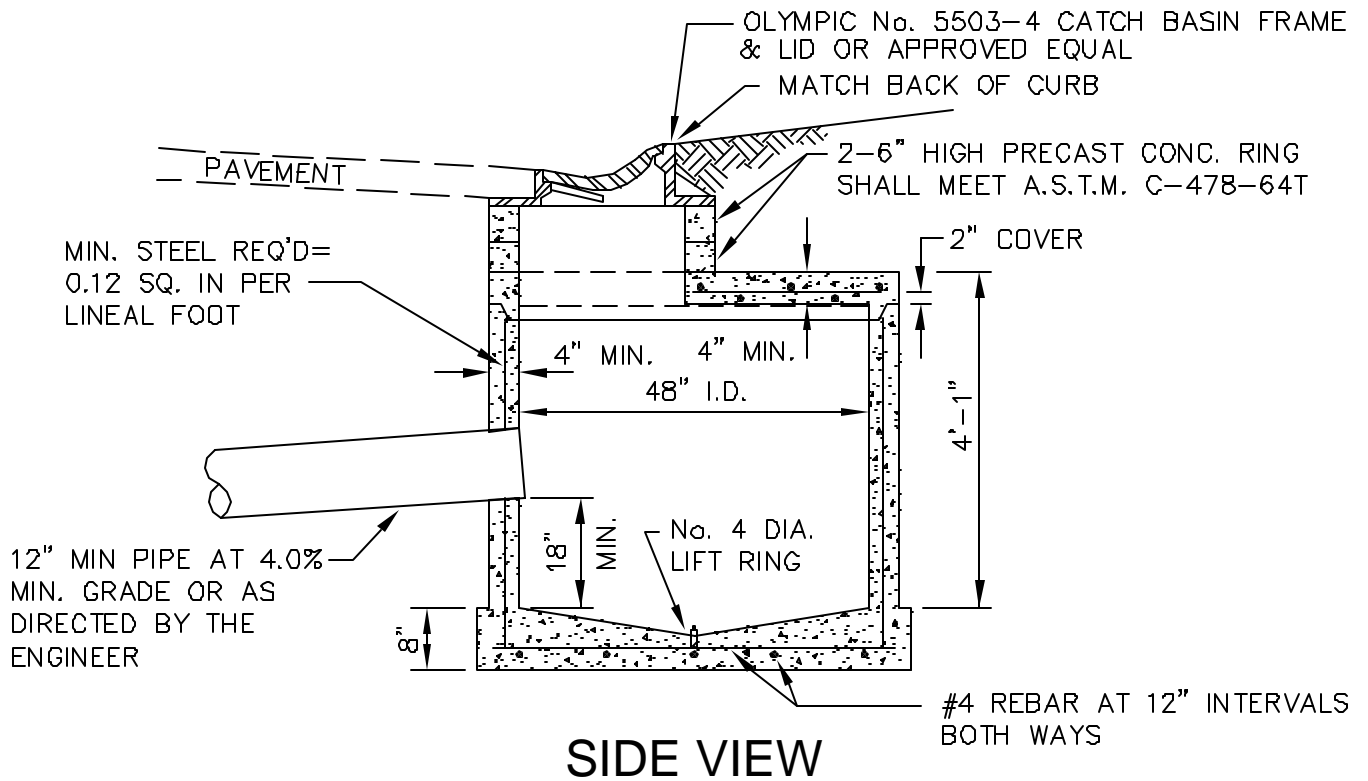

NOTES:

1. COMPRESSIVE STRENGTH OF CONC. SHALL BE MINIMUM 4000 P.S.I. EXCEPT BASE SLAB WHICH MAY BE 3000 P.S.I. BASE & BARREL SHALL BE CONNECTED BY CONTINUOUS STEEL.
2. SEE ASTM C-478-64T FOR DESIGN REQUIREMENTS.
3. AT CATCH BASIN, DELETE CONC. CURB & GUTTER, PAVE TO FACE OF CATCH BASIN INLET.



SCALE:
NTS
APPROVED:
RAR
REVISED:
11/29/02

**PRECAST CATCH BASIN,
TYPE II
FOR TYPE II CURB & GUTTER**

SECTION #
55.04
DETAIL #
55-11

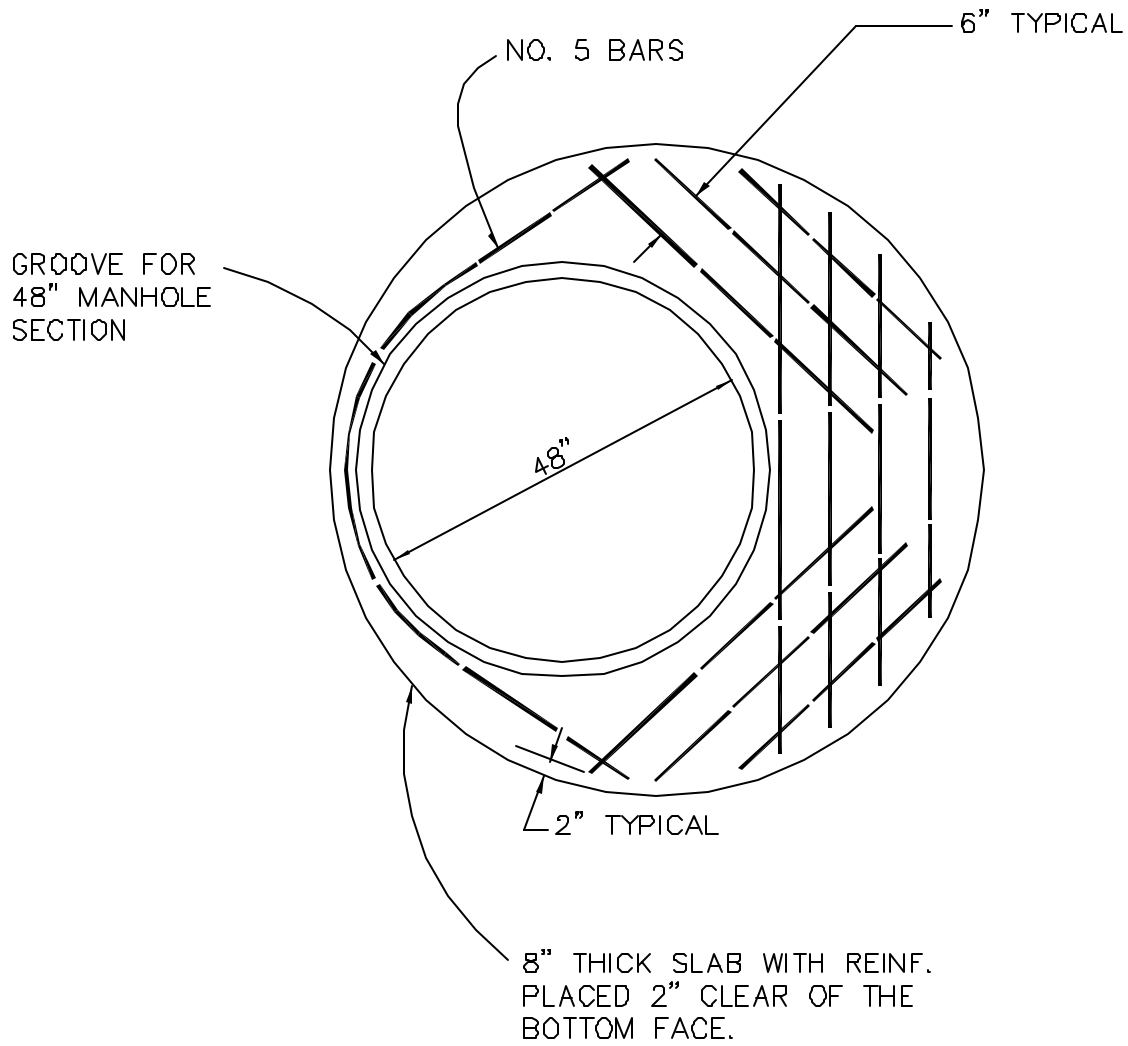

8" THICK SLAB WITH REINF.
 PLACED 2" CLEAR OF THE
 BOTTOM FACE.



SCALE:
 NTS
 APPROVED:
 RAR
 REVISED:
 11/29/02

**PRECAST
 CONCRETE REDUCING SLAB
 (72" TO 48")**

SECTION #
 55.04
 DETAIL #
 55-12

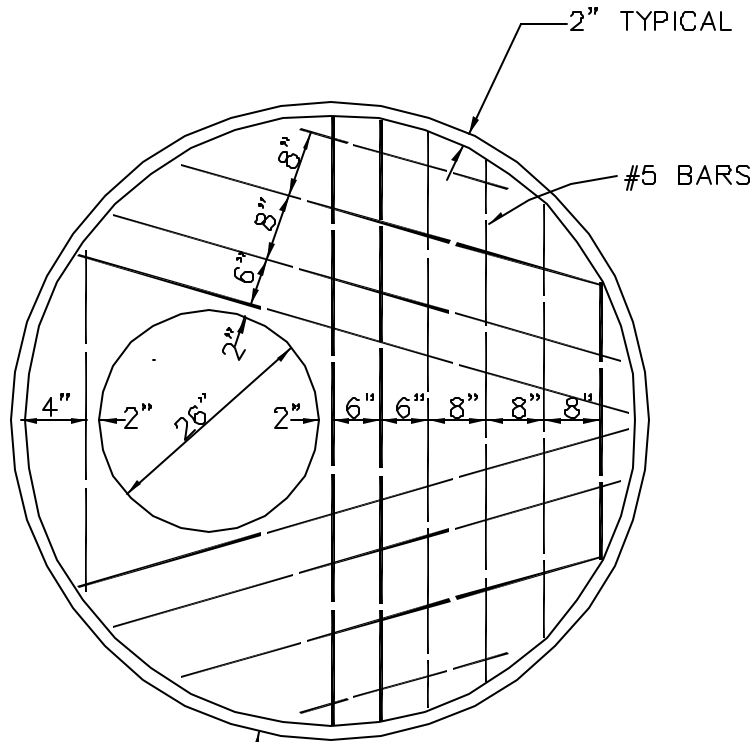

8" THICK SLAB WITH REINF.
 PLACED 2" CLEAR OF THE
 BOTTOM FACE.



SCALE:
 NTS
 APPROVED:
 RAR
 REVISED:
 11/29/02

**PRECAST
 CONCRETE REDUCING SLAB
 (72" OR 48" TO 26")**

SECTION #
 55.04
 DETAIL #
 55-13

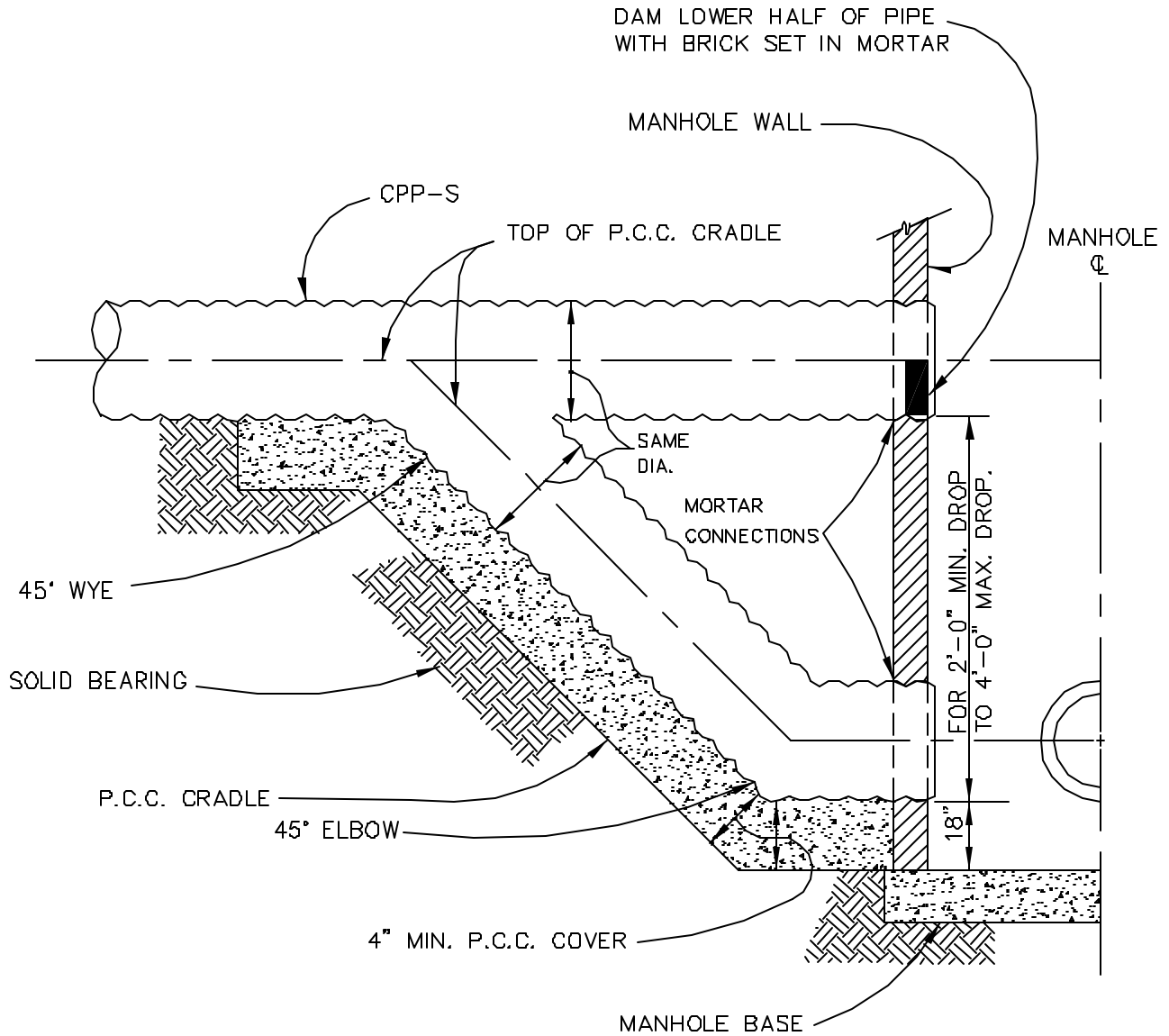

NOTES:

1. CONCRETE FOR CRADLE SHALL HAVE MIN. COMPRESSIVE STRENGTH OF 3000 P.S.I.
2. PROTRUSION OF PIPE INTO M.H. SHALL BE MAX. 1".



SCALE:
NTS
APPROVED:
RAR
REVISED:
11/29/02

STORM DRAIN DROP CONNECTION (2' MIN. DROP)

SECTION #
55.08

DETAIL #
55-14

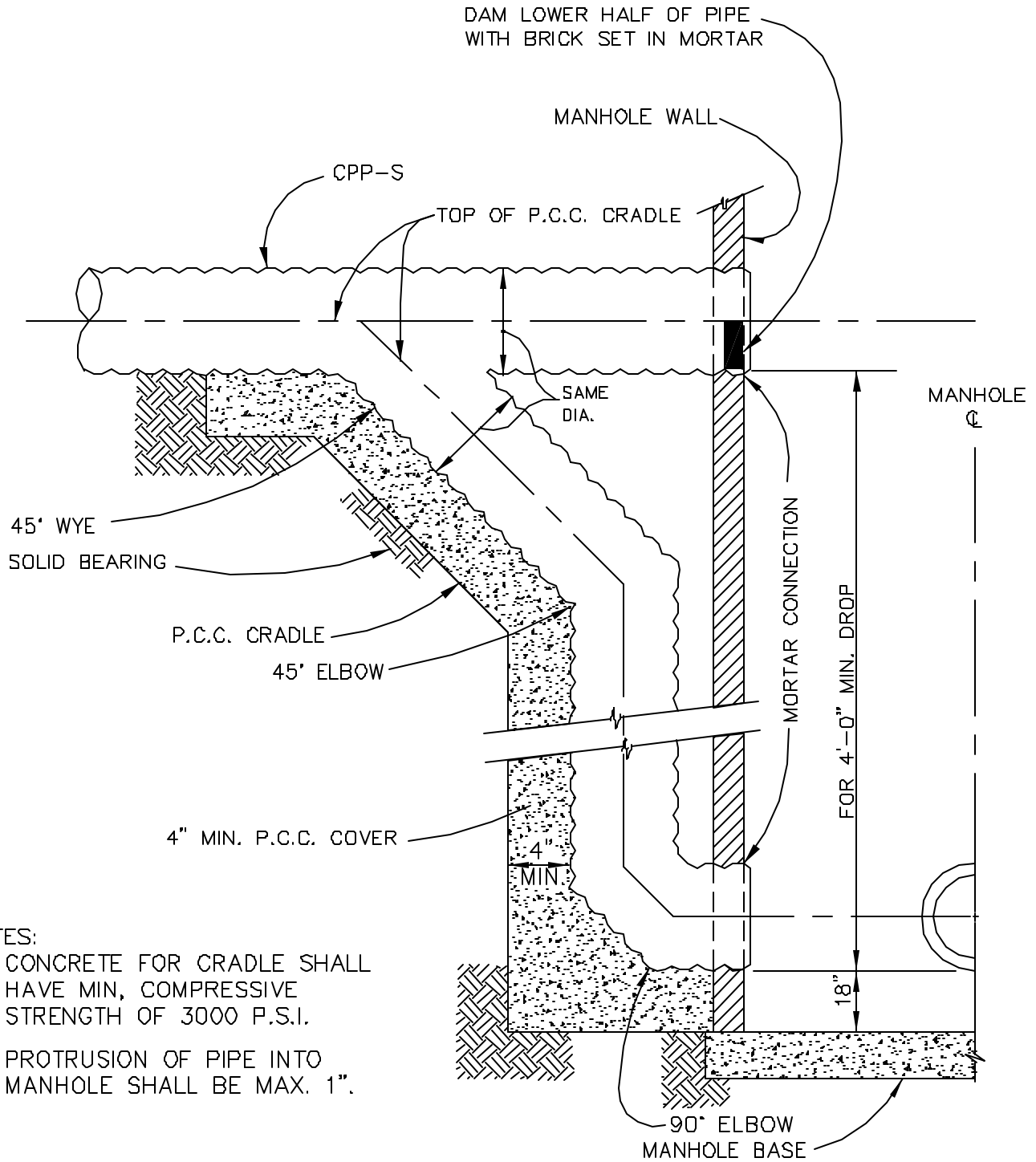

NOTES:

1. CONCRETE FOR CRADLE SHALL HAVE MIN. COMPRESSIVE STRENGTH OF 3000 P.S.I.
2. PROTRUSION OF PIPE INTO MANHOLE SHALL BE MAX. 1".



SCALE:
NTS
APPROVED:
RAR
REVISED:
11/29/02

STORM DRAIN DROP CONNECTION (4' MIN. DROP)

SECTION #
55.08

DETAIL #
55-15

CAST IRON RING & COVER SHALL BE OLYMPIC FOUNDRY NO. M1035 D/T, OR APPROVED EQUAL

CONCRETE COLLAR (SEE DETAIL 30-6)

MATCH INSIDE TOP OF PIPE TO INSIDE RING

12" CPP-S PIPE

ORIG. GROUND—DO NOT OVER EXCAVATE

FINISH GRADE

2-1/2' MIN.
3' MAX.

VARIABLE

VARIABLE

45°

45° ELL

CENTER OF CLEANOUT ELL IS STATIONING AS APPEARS ON THE PROFILE SHEETS

PROVIDE ADAPTORS IF C.O. IS ATTACHED TO PIPE LARGER THAN 10" IN DIA.

NOTE:
CONCRETE SHALL HAVE MINIMUM COMPRESSIVE STRENGTH OF 3000 P.S.I.

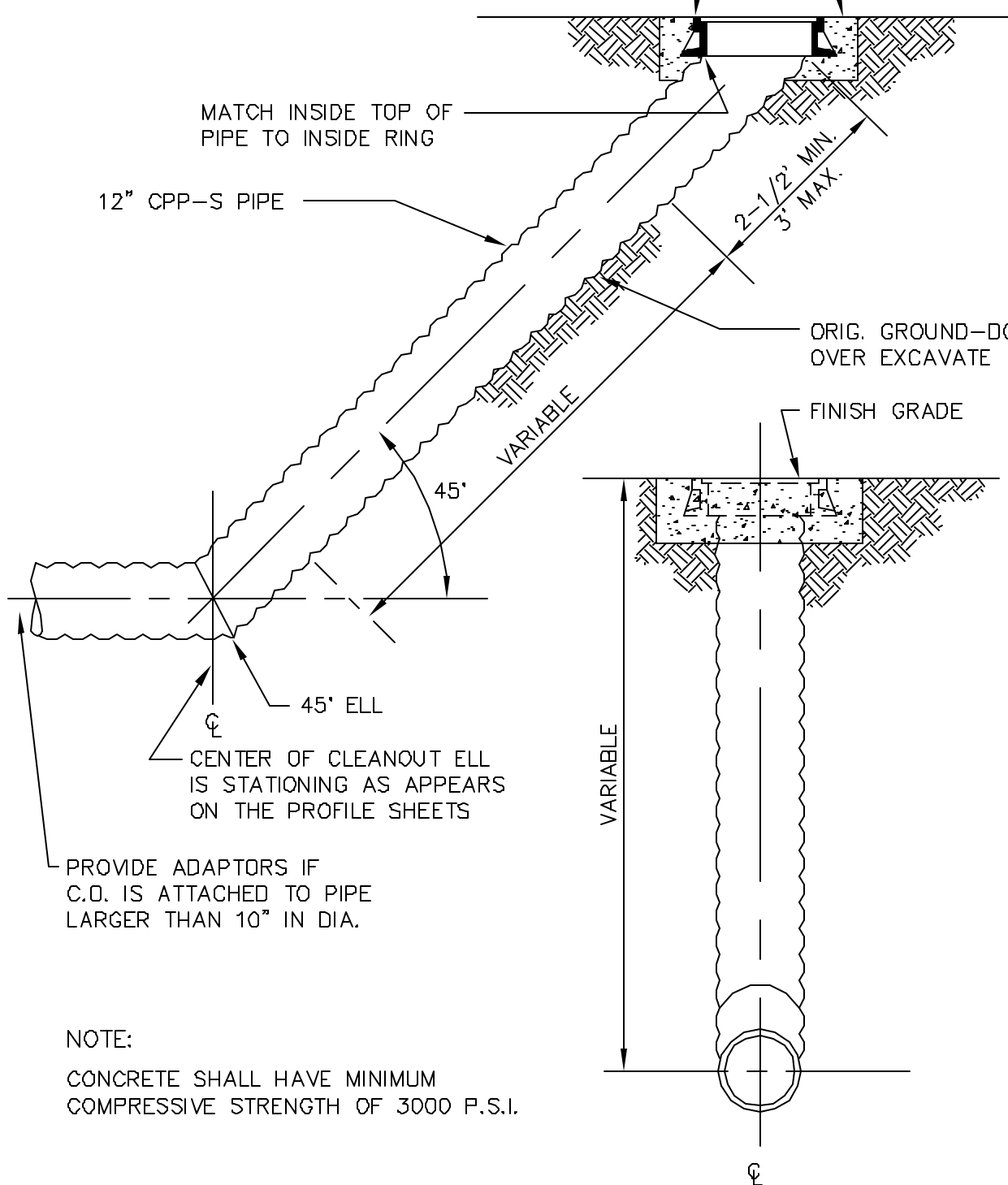

SCALE:
NTS
APPROVED:
RAR
REVISED:
11/29/02

STORM DRAIN CLEANOUT

SECTION #
55.09
DETAIL #
55-16

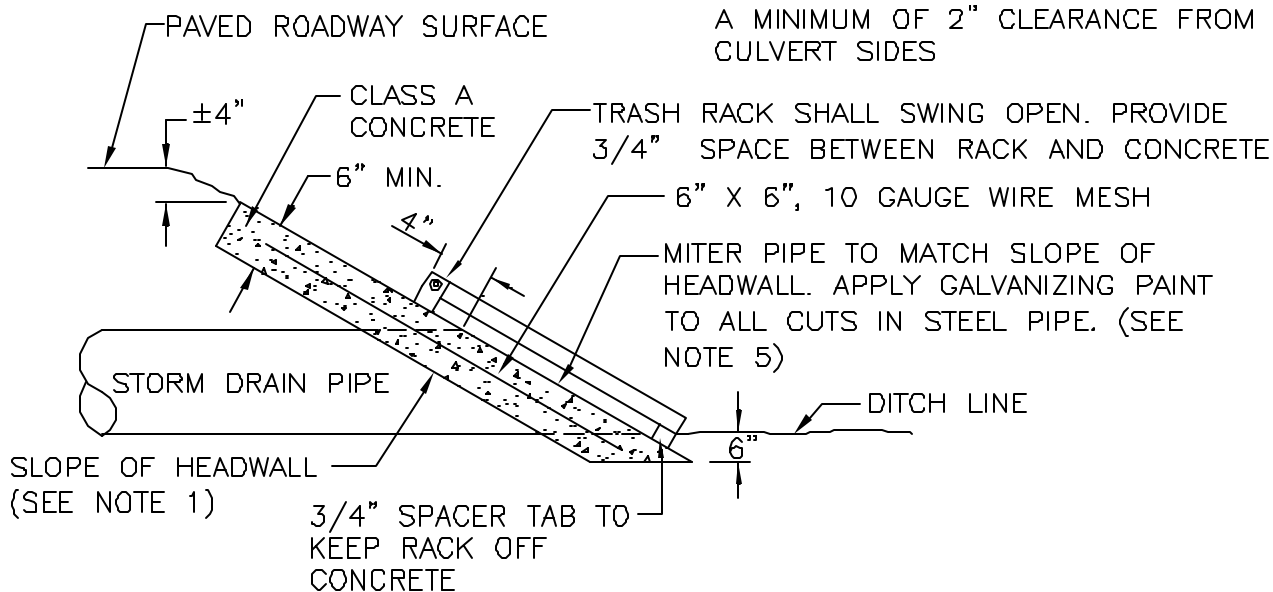
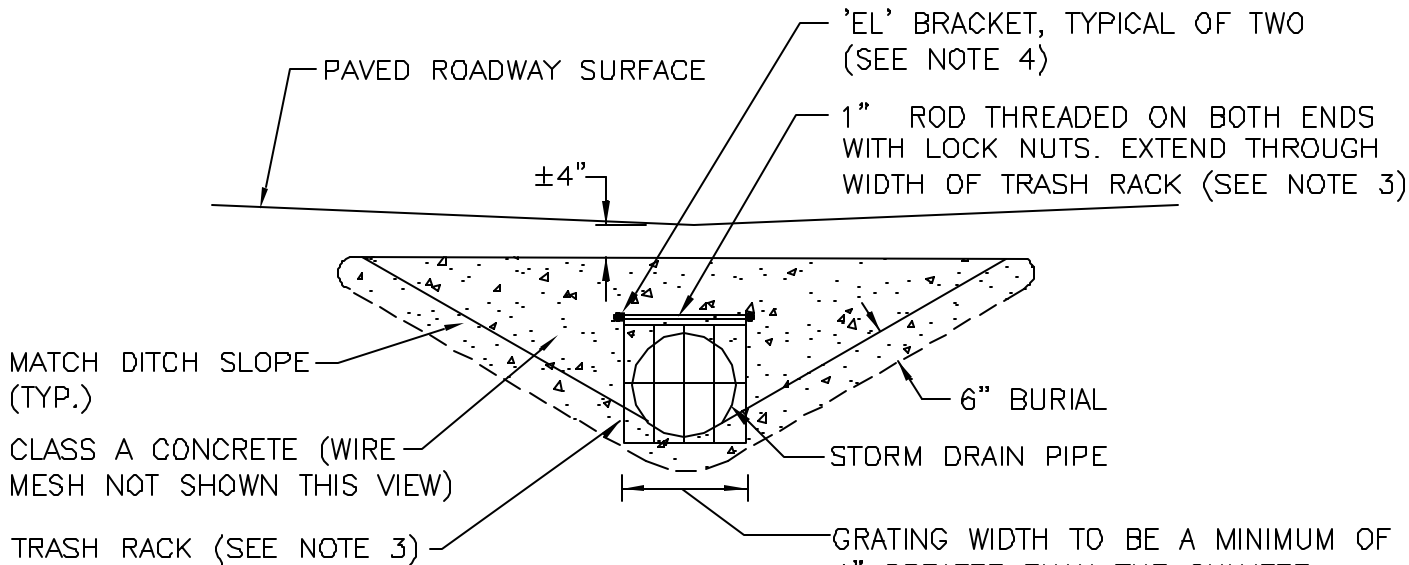

NOTES:

1. SLOPE OF HEADWALL SHALL BE 2:1 OR FLATTER AND SHALL BE DETERMINED BY THE ENGINEER.
2. TRASH RACKS SHALL BE REQUIRED ON HEADWALLS AT UP STREAM ENDS OF CULVERTS ENTERING CLOSED STORM DRAIN SYSTEMS.
3. GRATE, 'EL' AND THREADED ROD SHALL BE CONSTRUCTED OF FLAT BARS OF EITHER 6061 ALUMINUM OR HOT DIPPED GALVANIZED STEEL.
4. INSTALL 'EL' BRACKETS A MINIMUM OF 2" INTO WET CONCRETE.
5. IF CORRUGATED PLASTIC PIPE IS USED, EMPTY WATER FROM CORRUGATIONS ON MITERED ENDS AND THEN COMPLETELY FILL VOIDS WITH CONCRETE GROUT.



SCALE:
NTS
APPROVED:
RAR
REVISED:
11/29/02

SLOPED CULVERT HEADWALL WITH HINGED TRASH RACK

SECTION #
55.10

DETAIL #
55-17

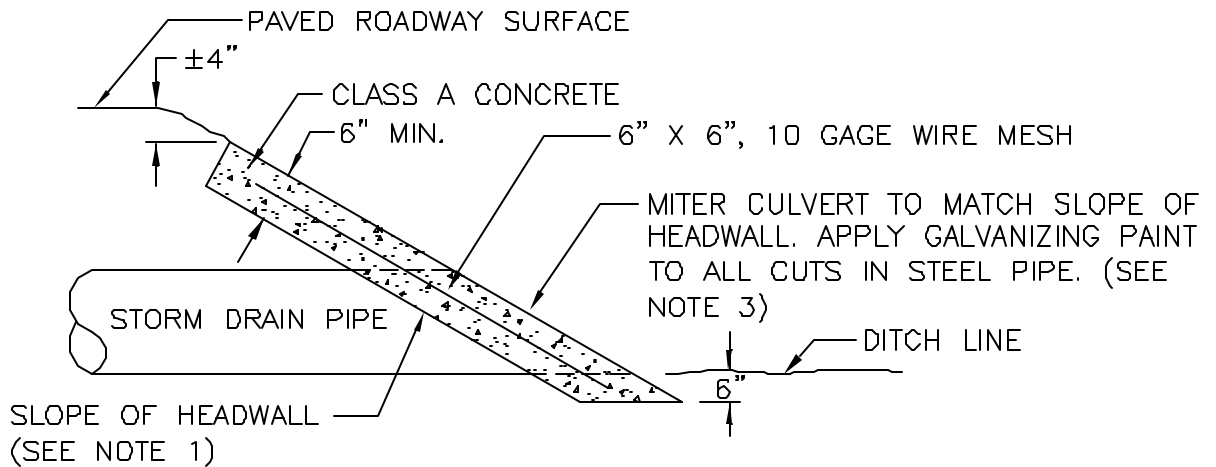
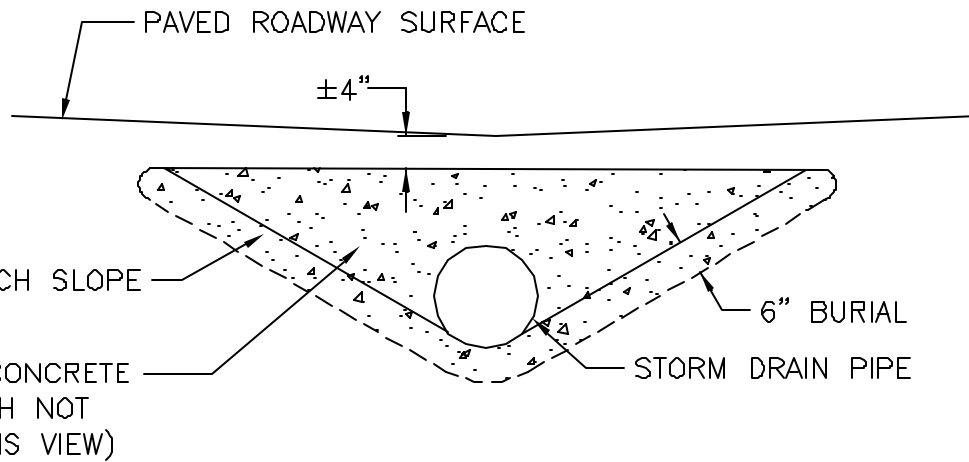

NOTES:

1. SLOPE OF HEADWALL SHALL BE 2:1 OR FLATTER AND SHALL BE DETERMINED BY THE ENGINEER.
2. TRASH RACKS SHALL BE REQUIRED ON HEADWALLS AT UP STREAM ENDS OF CULVERTS ENTERING CLOSED STORM DRAIN SYSTEMS.
3. IF CORRUGATED PLASTIC PIPE IS USED, EMPTY WATER FROM CORRUGATIONS ON MITERED ENDS AND THEN COMPLETELY FILL VOIDS WITH CONCRETE GROUT.



SCALE:
NTS
APPROVED:
RAR
REVISED:
11/29/02

SLOPED CULVERT HEADWALL

SECTION#
55-10
DETAIL #
55-18

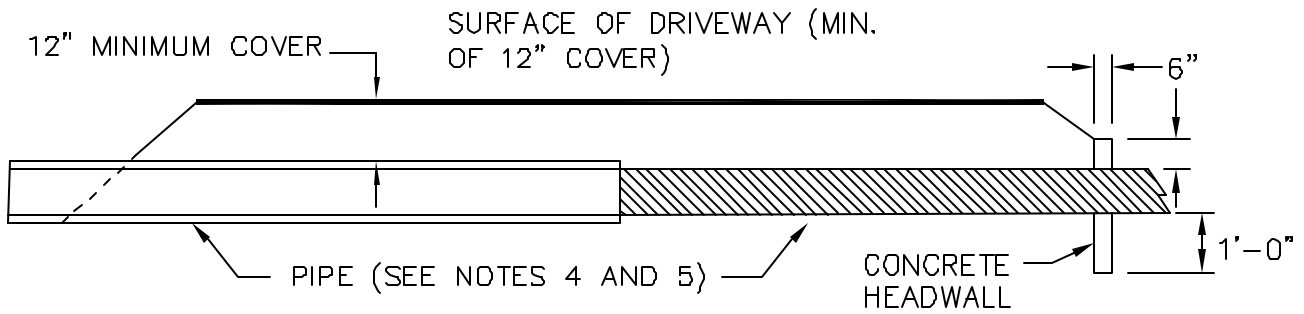

CULVERT CROSS SECTION

NOTES:

1. MINIMUM PIPE SIZE SHALL BE 12" IN DIAMETER AND 20 FEET IN LENGTH. PIPE SHALL EXTEND A MINIMUM OF ONE FOOT BEYOND THE TOE OF FILL.
2. PIPE SHALL BE INSTALLED PER MANUFACTURER'S SPECIFICATIONS TO SUPPORT AASHTO H-20 LOADING
3. ACCEPTABLE PIPE MATERIAL – CORRUGATED POLYETHYLENE PIPE WITH SMOOTH INNER LINER (CPP-S).
4. PROVIDE 5'x5'x12" DEEP RIP-RAP AT PIPE OUTLET WHEN THE PIPE SLOPE IS GREATER THAN 5%.



SCALE:
NTS
APPROVED:
RAR
REVISED:
11/29/02

TYPICAL CULVERT INSTALLATION FOR CITY DRIVEWAYS

SECTION#
55.12
DETAIL #
55-19

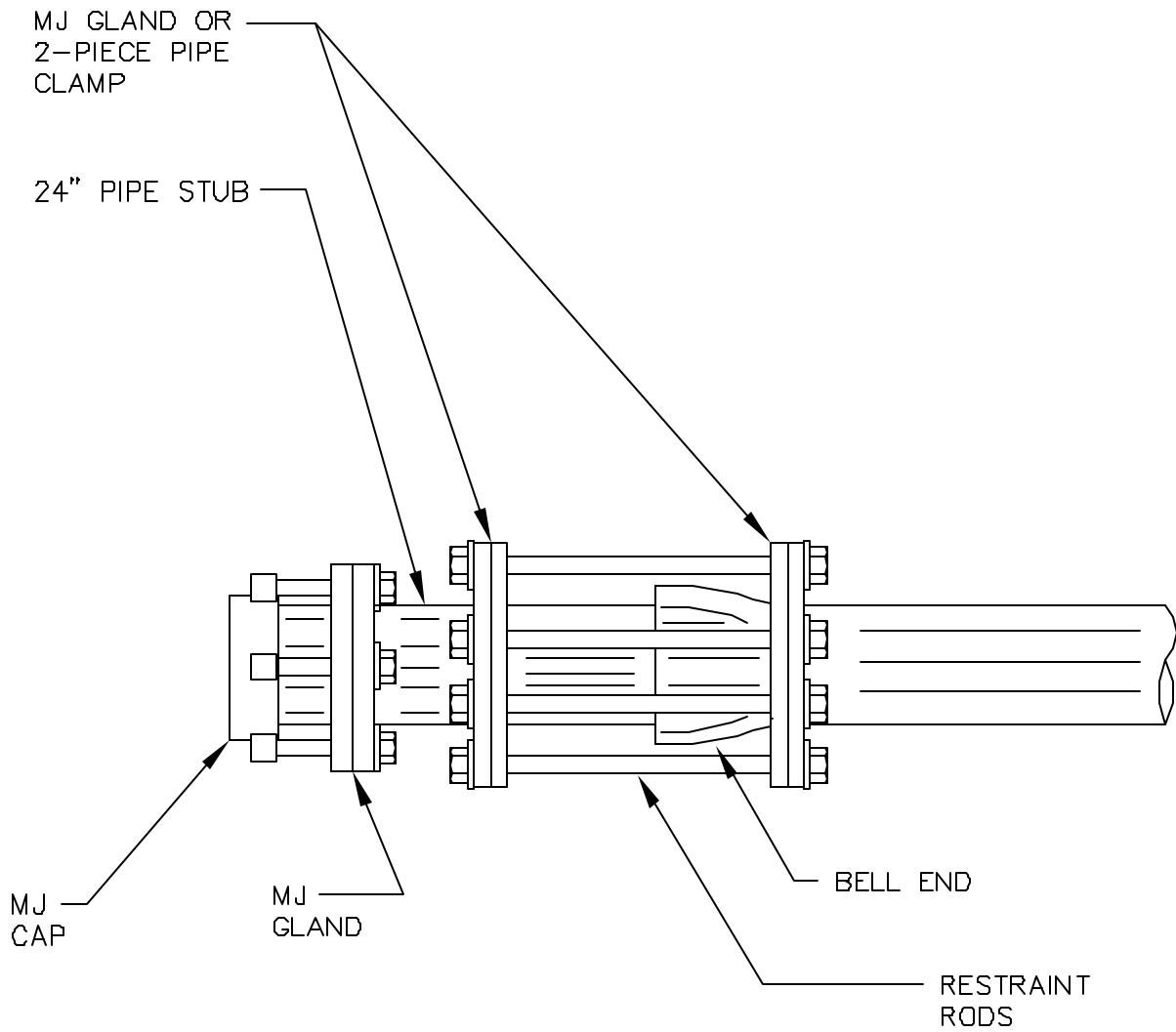

NOTES:

- 1. DIMENSIONS VARY WITH THE SIZE OF PIPE.
- 2. ON STRAIGHT PIPE ENDS, USE MECHANICAL JOINT DUCTILE IRON CAP.



SCALE:
NTS
APPROVED:
RAR
REVISED:
11/29/02

BELL AND SPIGOT PIPE CAP

SECTION #
60.02

DETAIL #
60-1

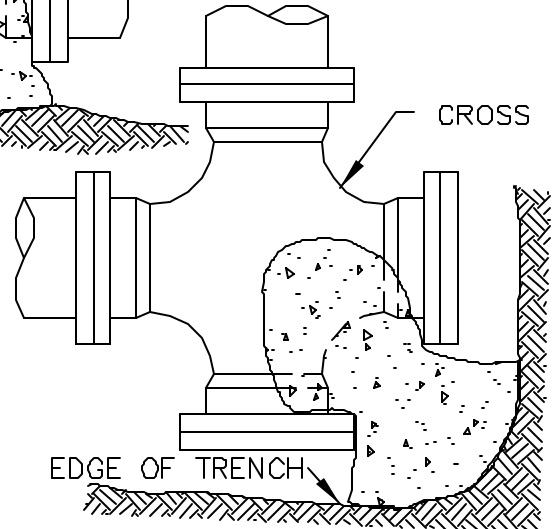
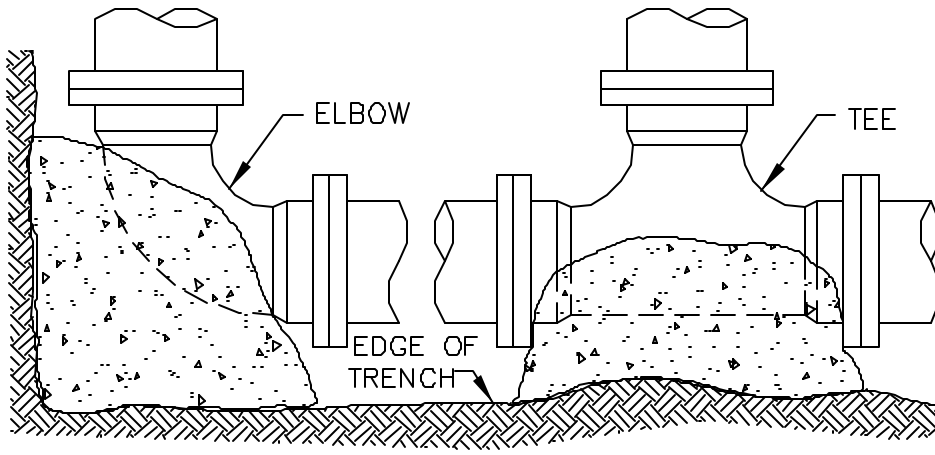

PIPE SIZE	MIN. BASE AREA SQ. FT.		
	90° BEND	45° BEND	PLUG
6"	2.0	1	2.0
8"	2.5	1.5	2.5
10"	4.5	2.5	4.5
12"	6	3.5	6
14"	8	4.5	8
16"	10.5	6	10.5
24"	24	13	24

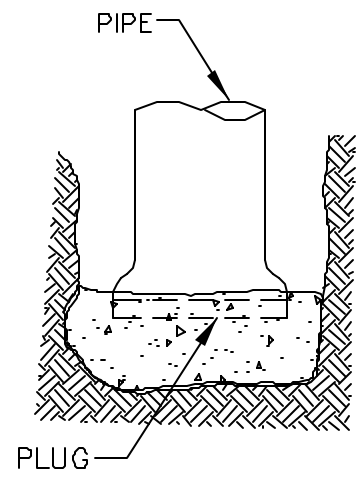
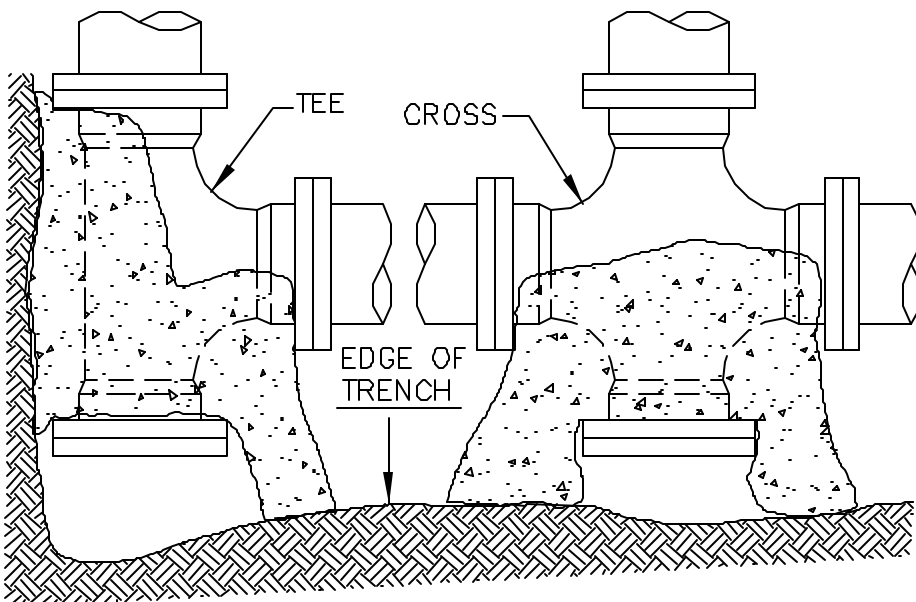

NOTES

1. DO NOT EMBED PIPE CONNECTION JOINTS IN CONCRETE- LEAVE EXPOSED FOR FUTURE REPAIR
2. WRAP ALL CONCRETE-EMBEDDED PIPE SECTIONS WITH POLY



SCALE:
NTS
APPROVED:
RAR
REVISED:
11/29/02

THRUST BLOCK

SECTION#
60.02
DETAIL #
60-2

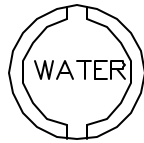

OPERATING NUT
& VALVE BOX

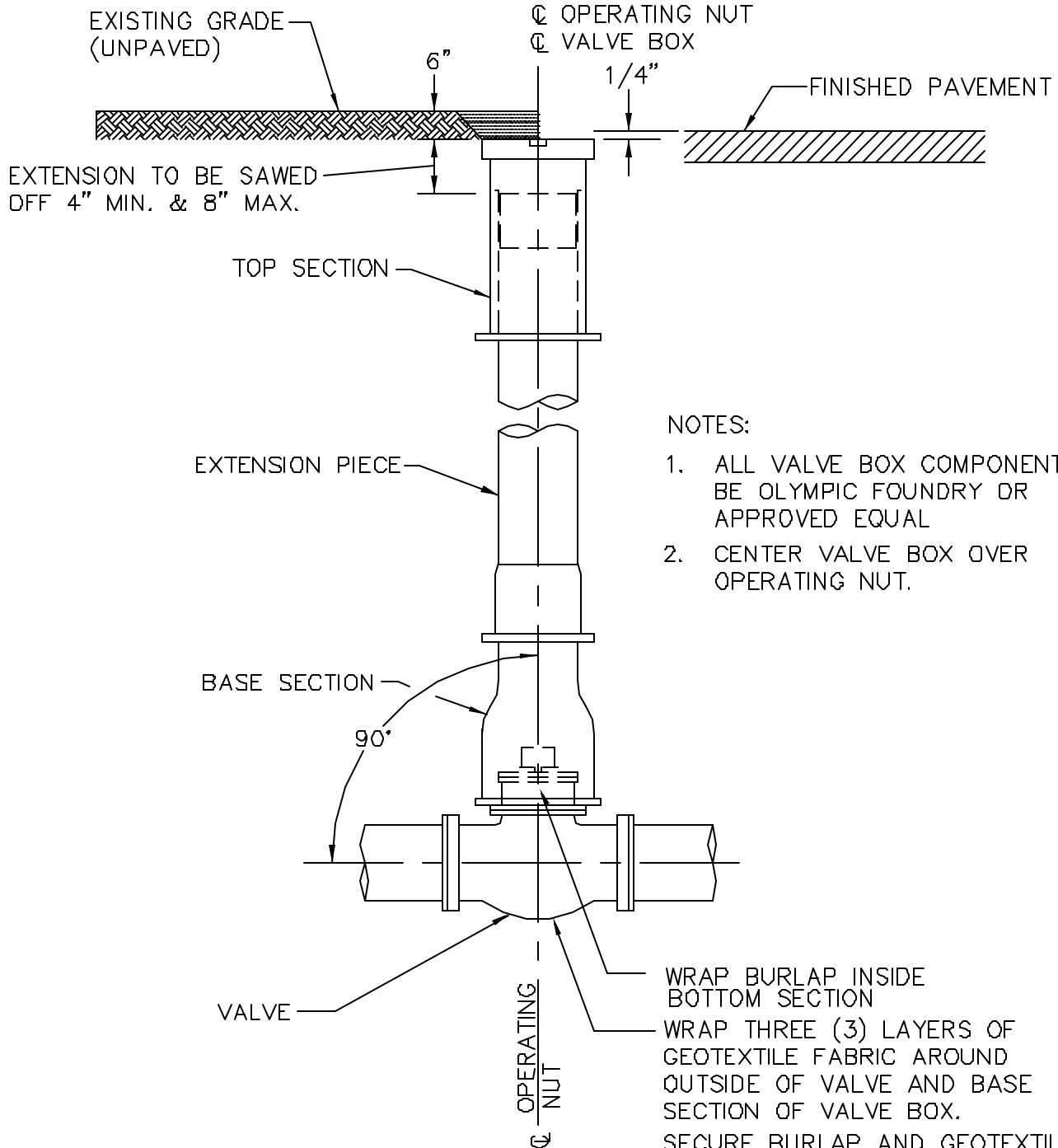

NOTES:

1. ALL VALVE BOX COMPONENTS TO BE OLYMPIC FOUNDRY OR APPROVED EQUAL
2. CENTER VALVE BOX OVER OPERATING NUT.

WRAP BURLAP INSIDE BOTTOM SECTION
WRAP THREE (3) LAYERS OF GEOTEXTILE FABRIC AROUND OUTSIDE OF VALVE AND BASE SECTION OF VALVE BOX.
SECURE BURLAP AND GEOTEXTILE TO PREVENT MOVEMENT DURING BACKFILLING OPERATIONS



SCALE:
NTS
APPROVED:
RAR
REVISED:
11/29/02

TYPICAL VALVE BOX

SECTION#
60.03

DETAIL #
60-3

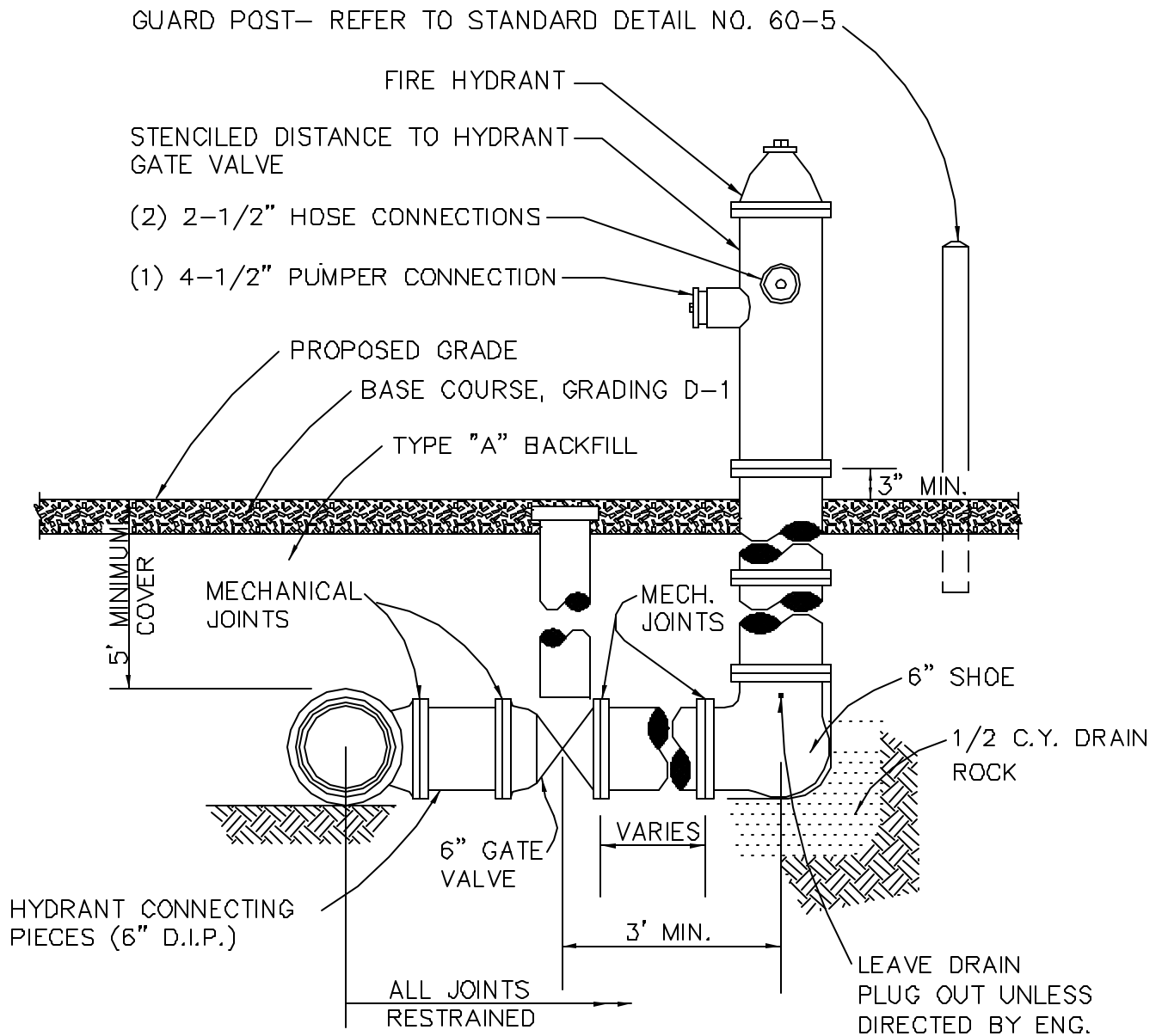

HYDRANT INSTALLATION NOTES:

1. HYDRANT BARREL MUST BE INSTALLED PLUMB AND THE LEG MUST BE INSTALLED LEVEL.
2. DRAIN PLUG SHALL BE LEFT OUT UNLESS DIRECTED BY ENGINEER.
3. SEE PLANS FOR LOCATION.
4. ALL HYDRANTS SHALL BE PAINTED CATERPILLAR YELLOW AFTER INSTALLATION.
5. AUXILIARY GATE VALVE BOX TO BE INSTALLED ACCORDING TO DETAIL FOR TYPICAL VALVE BOX.
6. VALVES SHALL BE RESTRAINED TO THE MAIN LINE AND HYDRANTS SHALL BE RESTRAINED TO THE VALVE.



SCALE:
NTS
APPROVED:
RAR
REVISED:
11/29/02

SINGLE PUMPER "L" BASE HYDRANT ASSEMBLY

SECTION#
60.04

DETAIL #
60-4

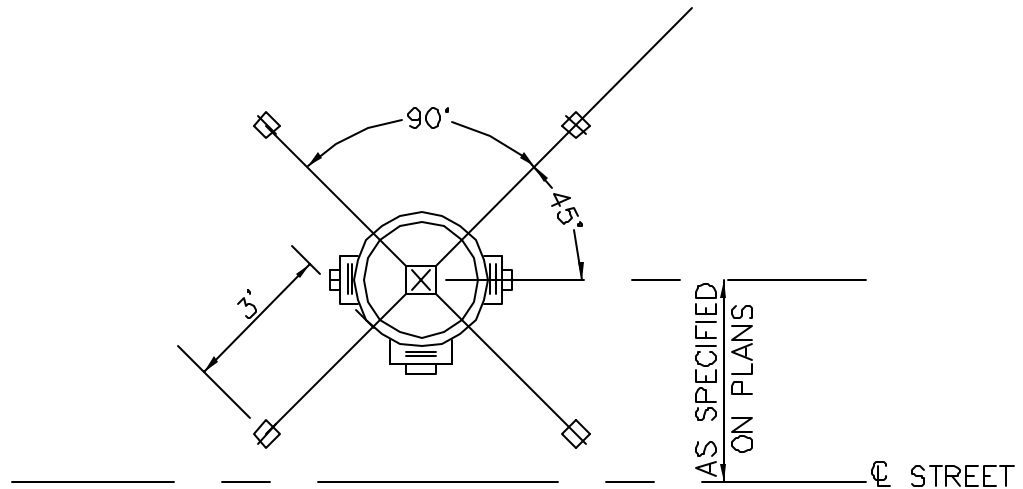

4" HEAVY WALL STEEL PIPE FILLED WITH CONCRETE, PAINTED CATERPILLAR YELLOW AFTER INSTALLATION

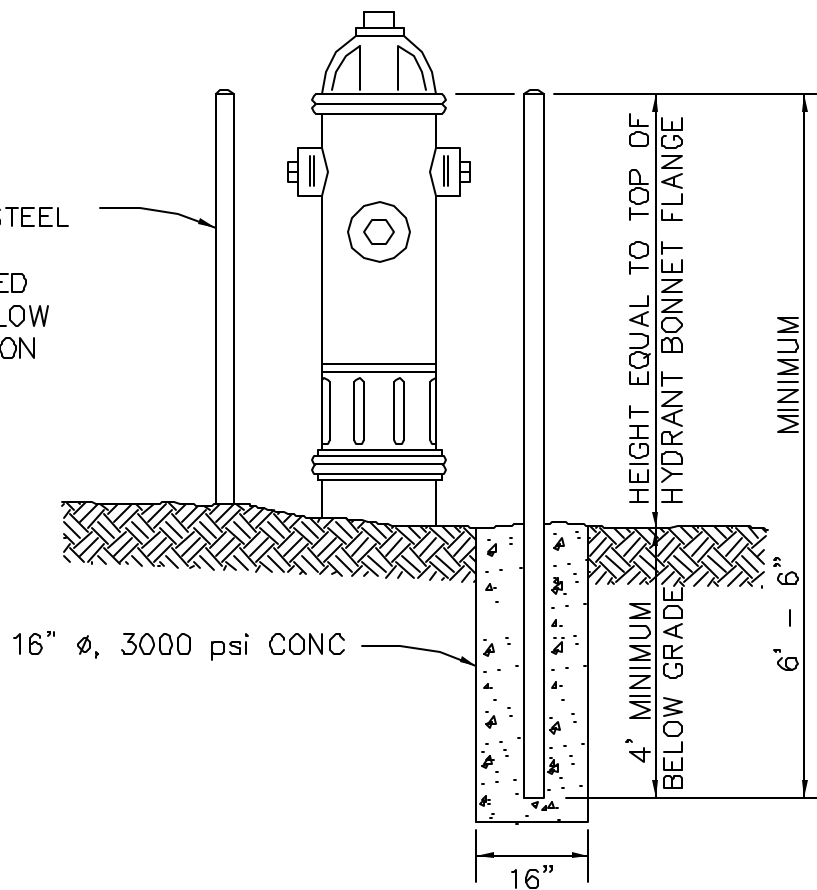

NOTES:

1. GUARD POSTS WILL BE FURNISHED & INSTALLED BY THE CONTRACTOR.
2. POSTS SHALL BE LOCATED TO ALLOW UNRESTRICTED ACCESS TO PUMPER AND HOSE CONNECTIONS.



SCALE:
NTS
APPROVED:
RAR
REVISED:
11/29/02

HYDRANT GUARD POSTS

SECTION#
60.04

DETAIL #
60-5

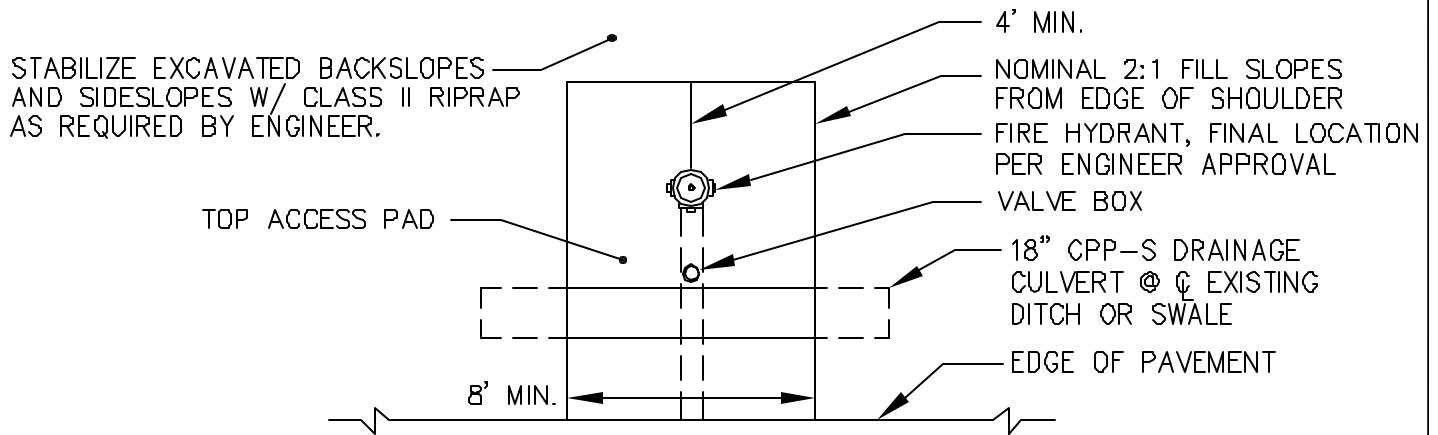

PLAN VIEW

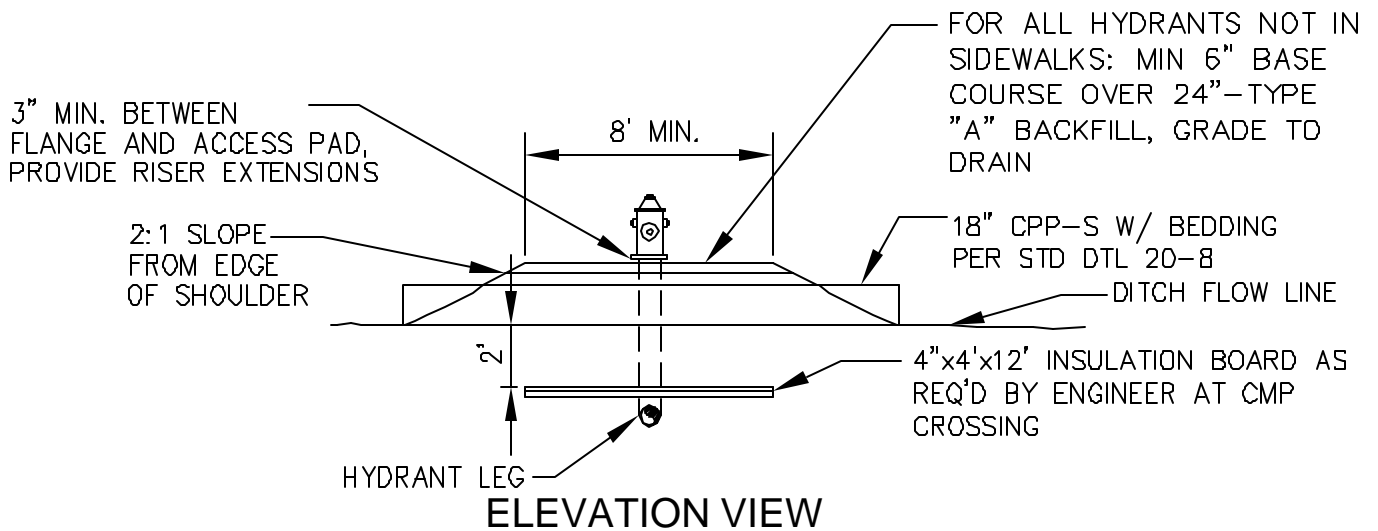

ELEVATION VIEW

NOTES:

1. SLOPE SURFACE OF HYDRANT PAD TO MATCH EXTENSION OF ROADWAY CROWN FROM EDGE OF ROAD TO DITCH LINE.



SCALE:
NTS
APPROVED:
RAR
REVISED:
11/29/02

FIRE HYDRANT ACCESS PAD

SECTION#
60.04

DETAIL #
60-6

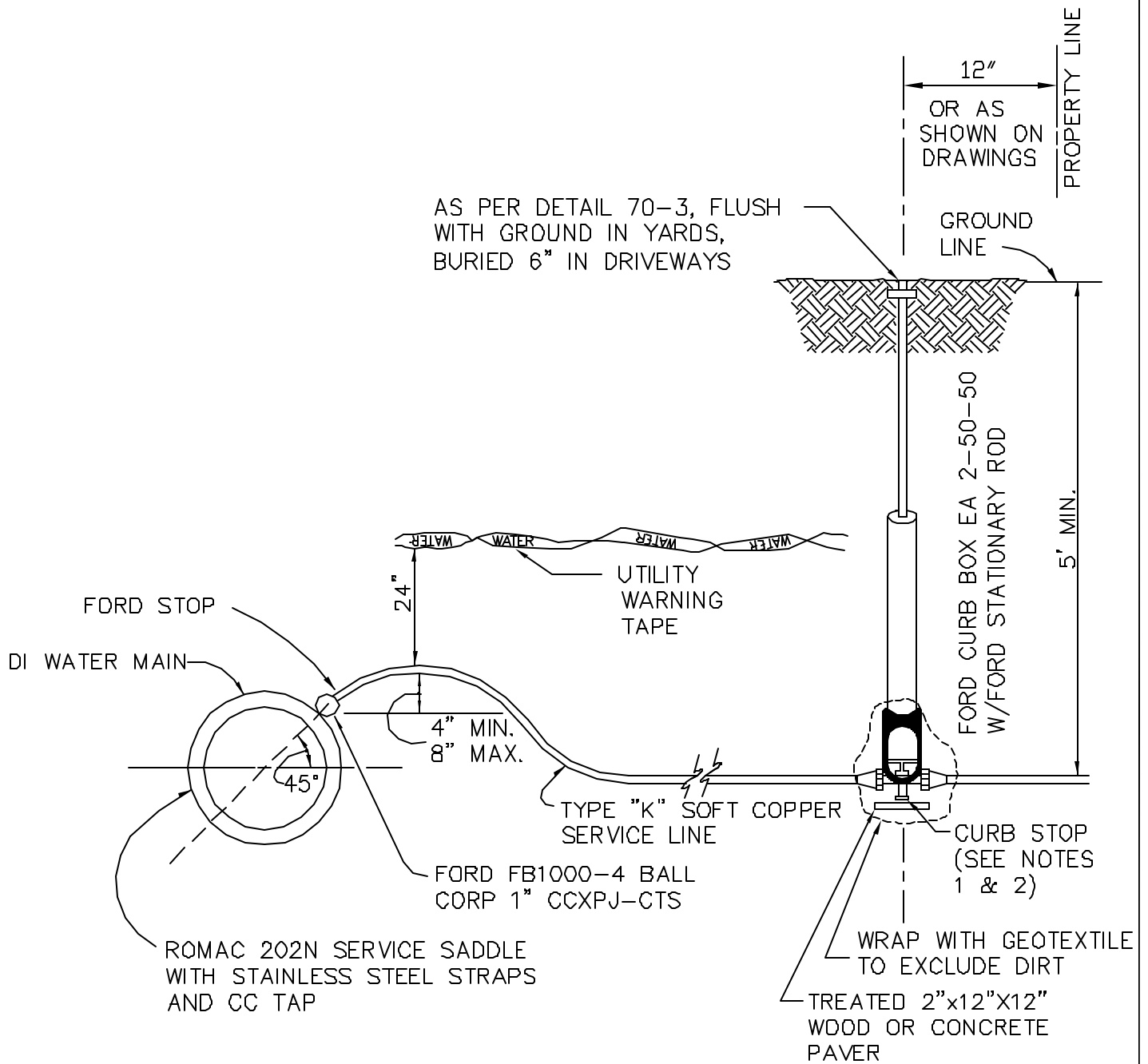

NOTES:

1. ROD TO BE ATTACHED TO CURB STOP WITH BRASS COTTER PIN-NO SUBSTITUTIONS.
2. USE FORD B41-444 BALL CURB STOP.
3. MUST USE PIPE ROUNDER IN PACK-JOINT AREA.



SCALE:
NTS
APPROVED:
RAR
REVISED:
11/29/02

**1" WATER SERVICE CONNECT
TO DUCTILE IRON MAIN**

SECTION#
60.06

DETAIL #
60-7

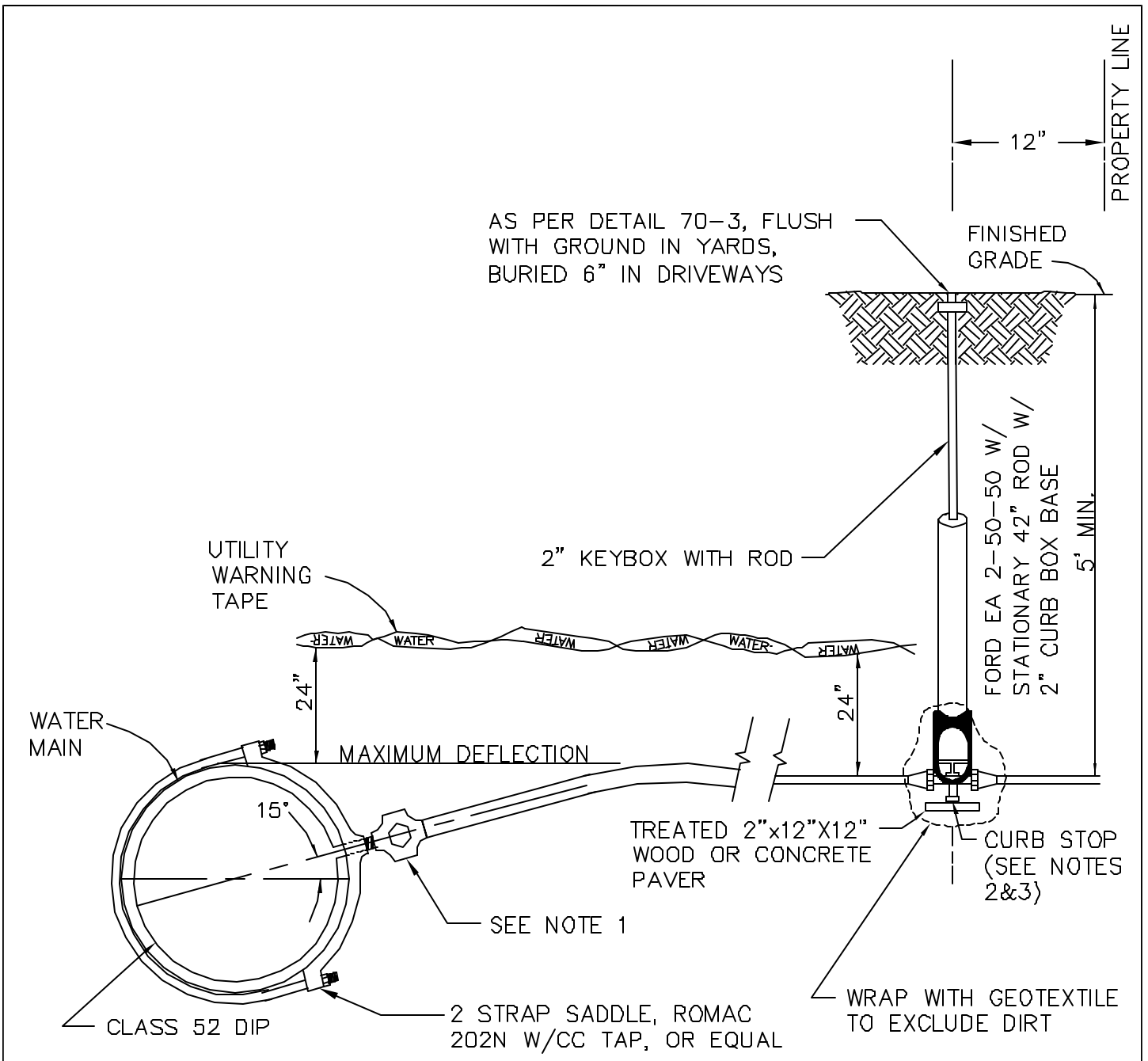

NOTES:

1. USE FORD FB1000-7 2" W/CCXPJ OR EQUAL.
2. ROD TO BE ATTACHED TO CURB STOP WITH BRASS COTTER PIN -NO SUBSTITUTIONS.
3. USE FORD B41-777 2" OR EQUAL.
4. 2" FROM MAIN TO PROPERTY LINE- THEN REDUCE TO 1 1/2" IF 1 1/2" SERVICE IS REQUIRED.
5. MUST USE PIPE ROUNDER IN PACK-JOINT AREAS.



SCALE:
NTS
APPROVED:
RAR
REVISED:
11/29/02

WATER SERVICE CONNECT

2"

SECTION#
60.06
DETAIL #
60-8

FINISH GRADE ELEVATION



FORD EA 2-50-50 W/ FORD STATIONARY
42" ROD, ADJUST HEIGHT FOR 6" BURIAL
BELOW FINISH GRADE (IN ROADWAYS).

6" BURIAL BELOW
FINISH GRADE IN
STREETS, TYPICAL

DUCTILE IRON
WATER MAIN.

8" BRASS
NIPPLE

2"Ø TYPE K COPPER PIPE,
EXTEND TO DAYLIGHT AT
ROAD SHOULDER, BEND END
HORIZONTAL W/ RADIUS.

INSTALL LOCKING MJ
GLAND AT ALL CAPS.

FORD FB 1000-7
2" CURB STOP W/
CC x PJ OR EQUAL

FACTORY INSTALLED
MECHANICAL CAP ON
END OF MAIN

NOTE:

1. ENGINEER APPROVAL REQUIRED BEFORE UTILIZING WATER MAIN BLOWOFF.



SCALE:
NTS
APPROVED:
RAR
REVISED:
11/29/02

WATER MAIN BLOWOFF

SECTION #
MISC.

DETAIL #
60-9

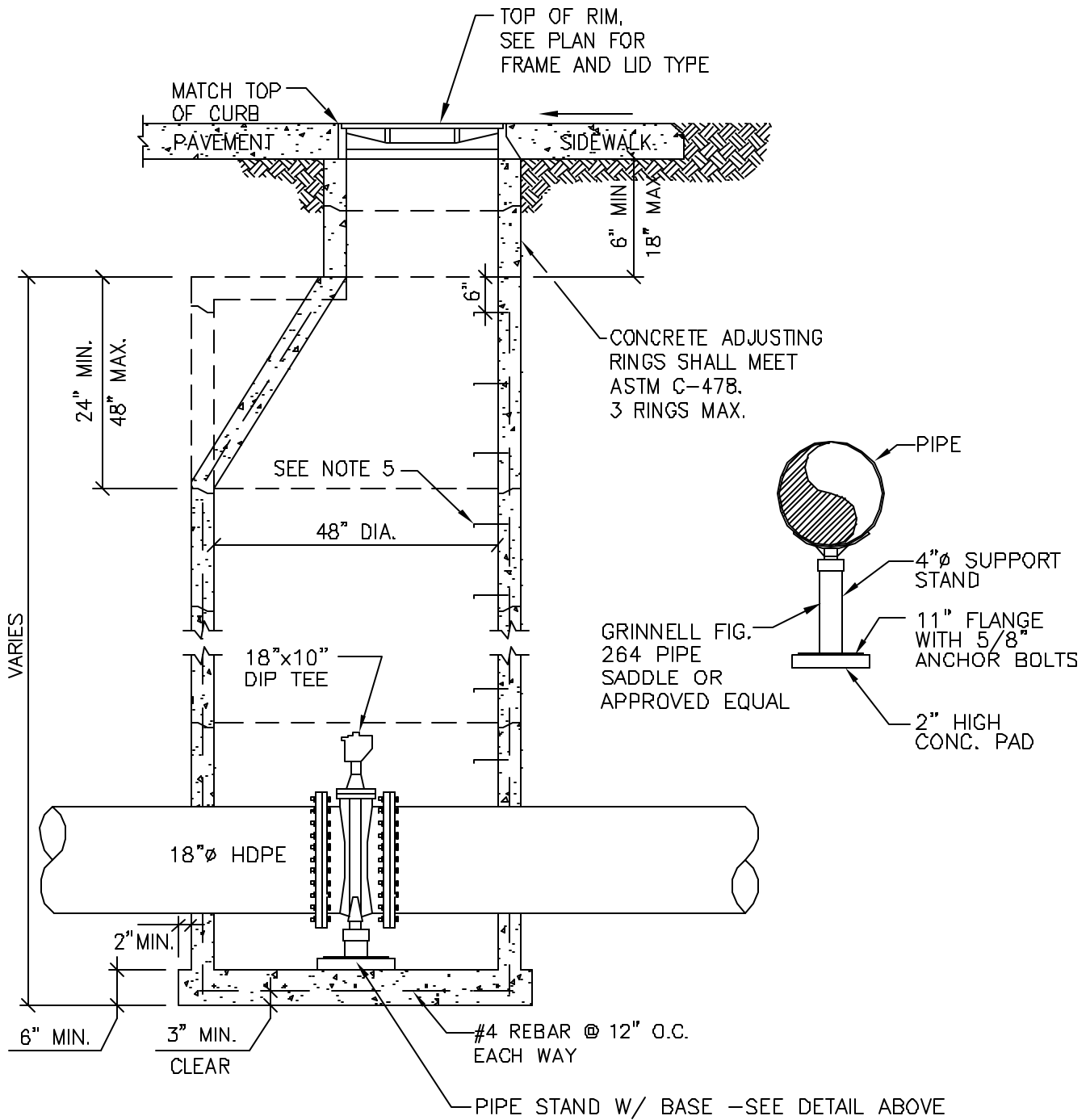

SCALE:
NTS
APPROVED:
RAR
REVISED:
11/29/02

AIR RELEASE VALVE -CONC

SECTION#
MISC.

DETAIL #
60-10



SCALE:
NTS
APPROVED:
RAR
REVISED:
11/29/02

AIR RELEASE VALVE

SECTION#
MISC.
DETAIL #
60-11

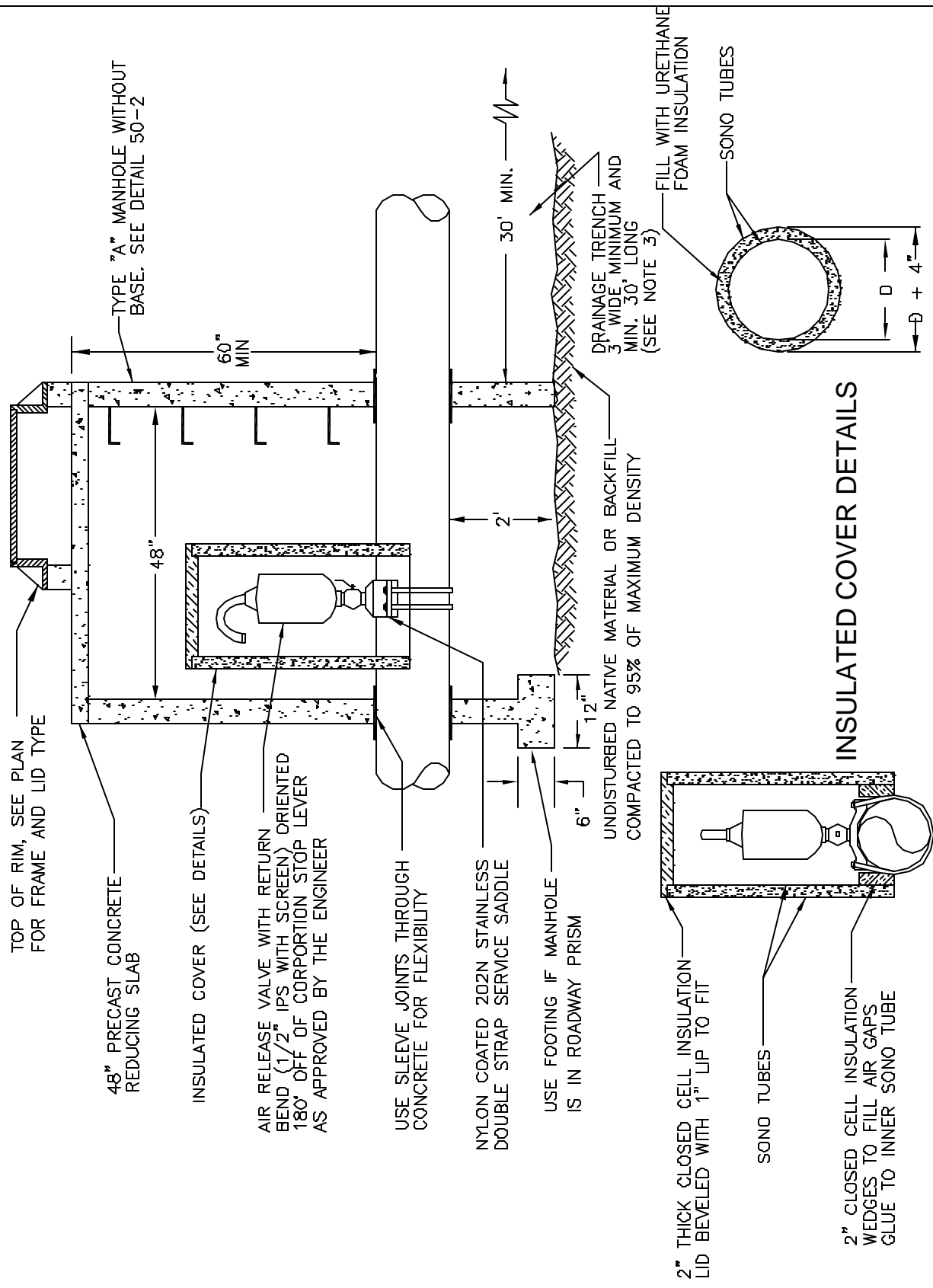

INSULATED COVER DETAILS

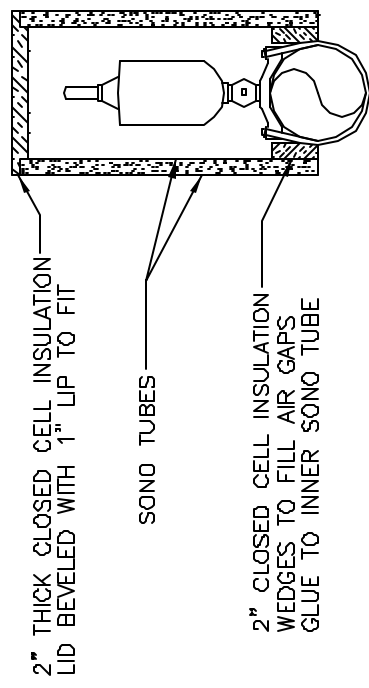

TOP VIEW

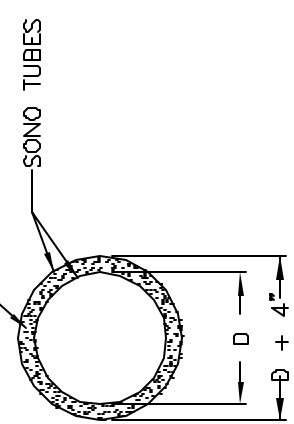

SEIVE SIZE	% PASSING
2"	100
.4"	0-10
1"	0-3

- NOTES:
1. PVC DRAIN TO DAYLIGHT MAY BE SUBSTITUTED FOR DRAINAGE TRENCH IF APPROVED BY ENGINEER.
 2. SONO TUBES SHALL BE CONCENTRIC TO INSURE A MINIMUM OF 2" OF INSULATION AT ALL POINTS. TRIM TUBES AND INSULATION TO FIT CURVATURE OF PIPE.
 3. FILL DRAIN TRENCH WITH MATERIAL AS DESCRIBED IN TABLE:

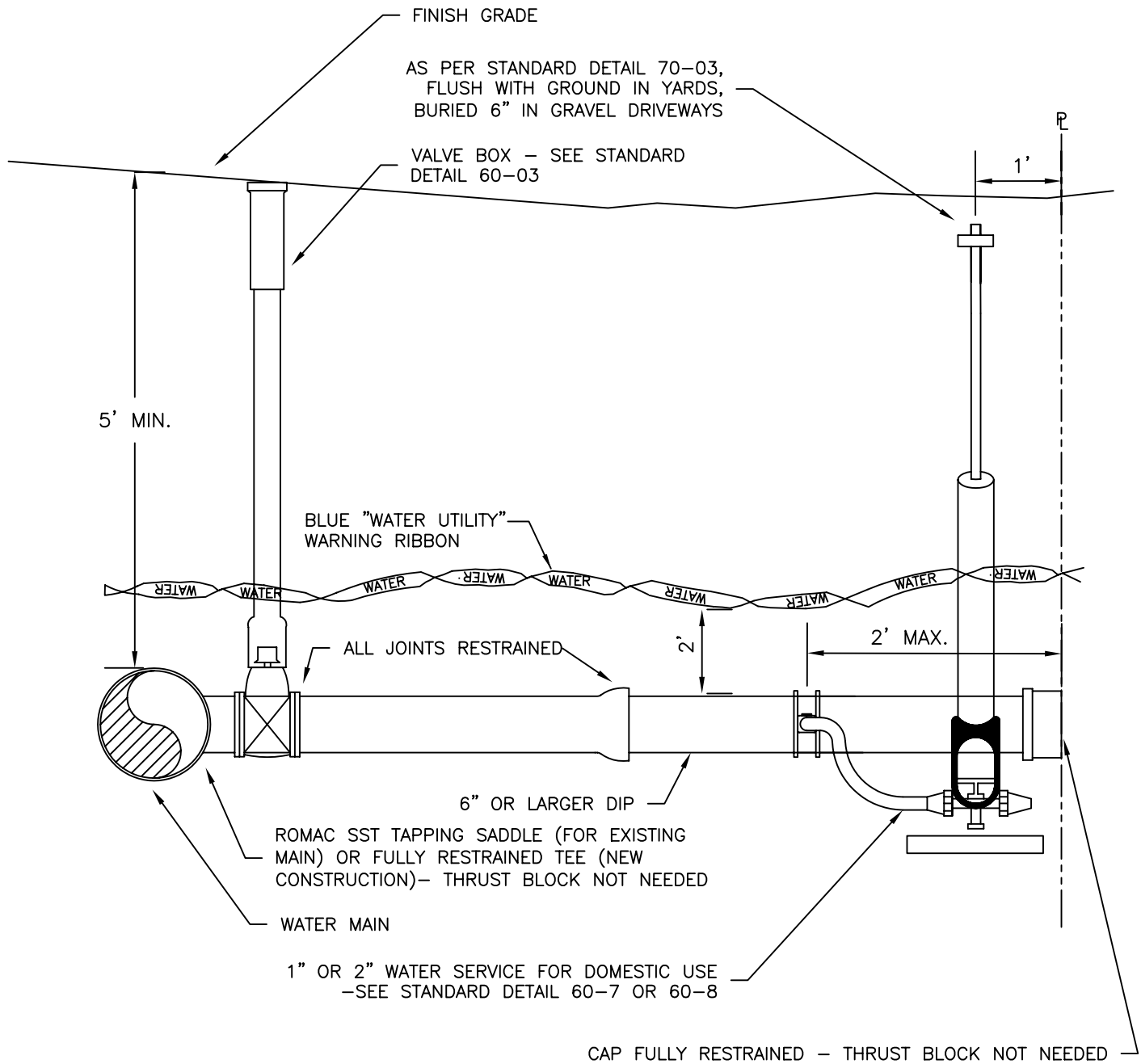

- NOTES:
1. GROUND COVER SHALL BE 5' MINIMUM INCLUDING UNDER DITCHES.
 2. WATER PIPE SHALL BE 6" MINIMUM D.I.P.
 3. ALL CONNECTIONS SHALL BE FULLY RESTRAINED (TYPICALLY MEGALUGED OR CONNECTED WITH FIELD-LOCK GASKETS OR ROMAC GRIP RING).
 4. HORIZONTAL DISTANCE BETWEEN CURB STOP AND CAP SHALL BE 4' MAXIMUM.
 5. SWING-TIES TO CAP ARE NOT NEEDED IF THE RELATIONSHIP BETWEEN THE CAP AND THE CURBSTOP IS GIVEN AND SWING-TIES TO CURB STOP ARE PROVIDED.
 6. COMMERCIAL SERVICES SHALL BE TESTED TO FIRELINE STANDARDS. SEE NFPA 24 CHAPTER 9.

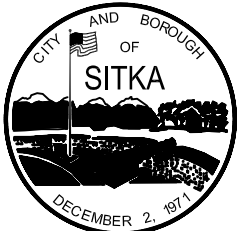

SCALE:
NTS
APPROVED:
DGJ
REVISED:
1/12/04

COMMERCIAL FIRELINE AND DOMESTIC SERVICE

SECTION#
60-TBA
DETAIL #
60-12



SCALE:
NTS
APPROVED:
RAR
REVISED:
11/29/02

FIELD BOOK INDEX

SECTION #
65.02

DETAIL #
65-1

Page	INDEX Location	Date	Description	2148 01
2	Third Ave.	9-8-86	Begin retracement & establishment of "P-line"	
3-6	Third Ave.	9-9-86	Complete "P-line" & determine falling of Reeve Blvd.	
7-12	Third Ave.	9-11-86	Tie property corners from "P-line"	
13-16	Third Ave.	9-13-86	Establish L Construction from "P-line"	
17	Third Ave.	9-15-86	" " " "	
18-20	" "	9-17-86	Slope stakes S. E. cor. Third & Post	
21-23	" "	9-20-86	R.P. 20+00 to Nelchina, 26+50 & 31+03.35	
24-27	" "	9-24-86	R.P.'s to E & S.I.'s	
28-40	" "	10-4, 10-5-86	Luminaires	
41	" "	10-7-86	R.P. S.I. 3rd & Post	
42	" "	10-8-86	Stake Load Ctr.	
43-50	" "	10-9-86	Curb & Gutter staking	
51-53	" "	10-10-86	Stake Load Ctr. & Luminaires	
54-55	" "	10-18-86	J-Doxes, Post & Third, Concrete St. & Third grades	
56	" "	10-24-86	P.P. Elev's	
57	" "	11-7-86	Storm drain MH	
58-70	" "	7-25-87	Before & after Ex X-S	
71	" "	7-29-87	As Built curb	
72-73	" "	7-31-87	Curb & gutter Rt. side 17+18 to Nelchina	
74-75	" "	8-3-87	Restake C & G on Nelchina St.	
76-77	" "	8-3-87	Curb & gutter 3rd Ave.	
78-79	" "	8-3-87	Curb & gutter Post Rd.	

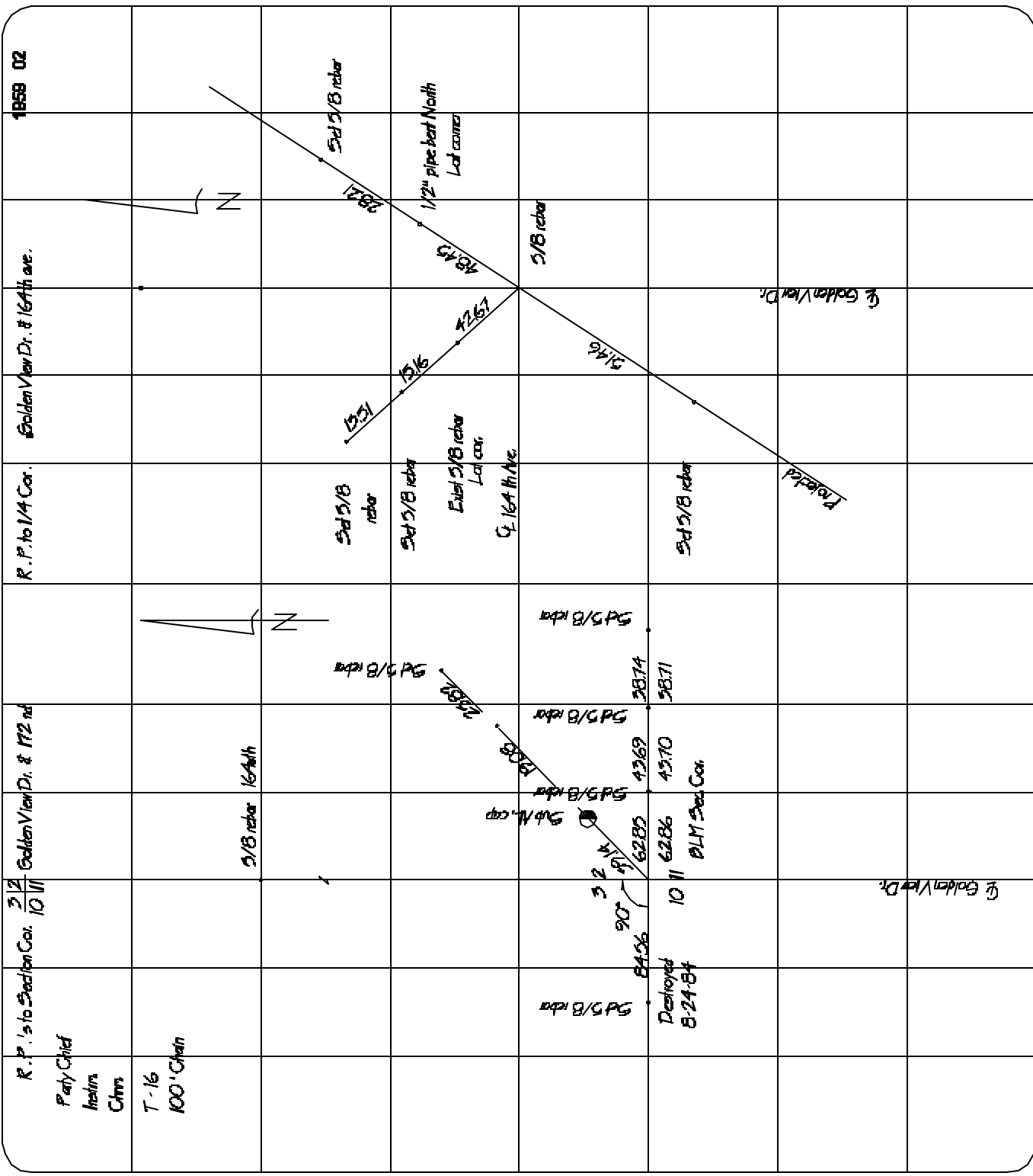

SCALE:
NTS
APPROVED:
RAR
REVISED:
11/29/02

CONTROL REFERENCE POINTS

SECTION #
65.02

DETAIL #
65-2



SCALE:
NTS
APPROVED:
RAR
REVISED:
11/29/02

MONUMENT RECOVERY AND HORIZONTAL CONTROL

SECTION #
65.02

DETAIL #
65-3

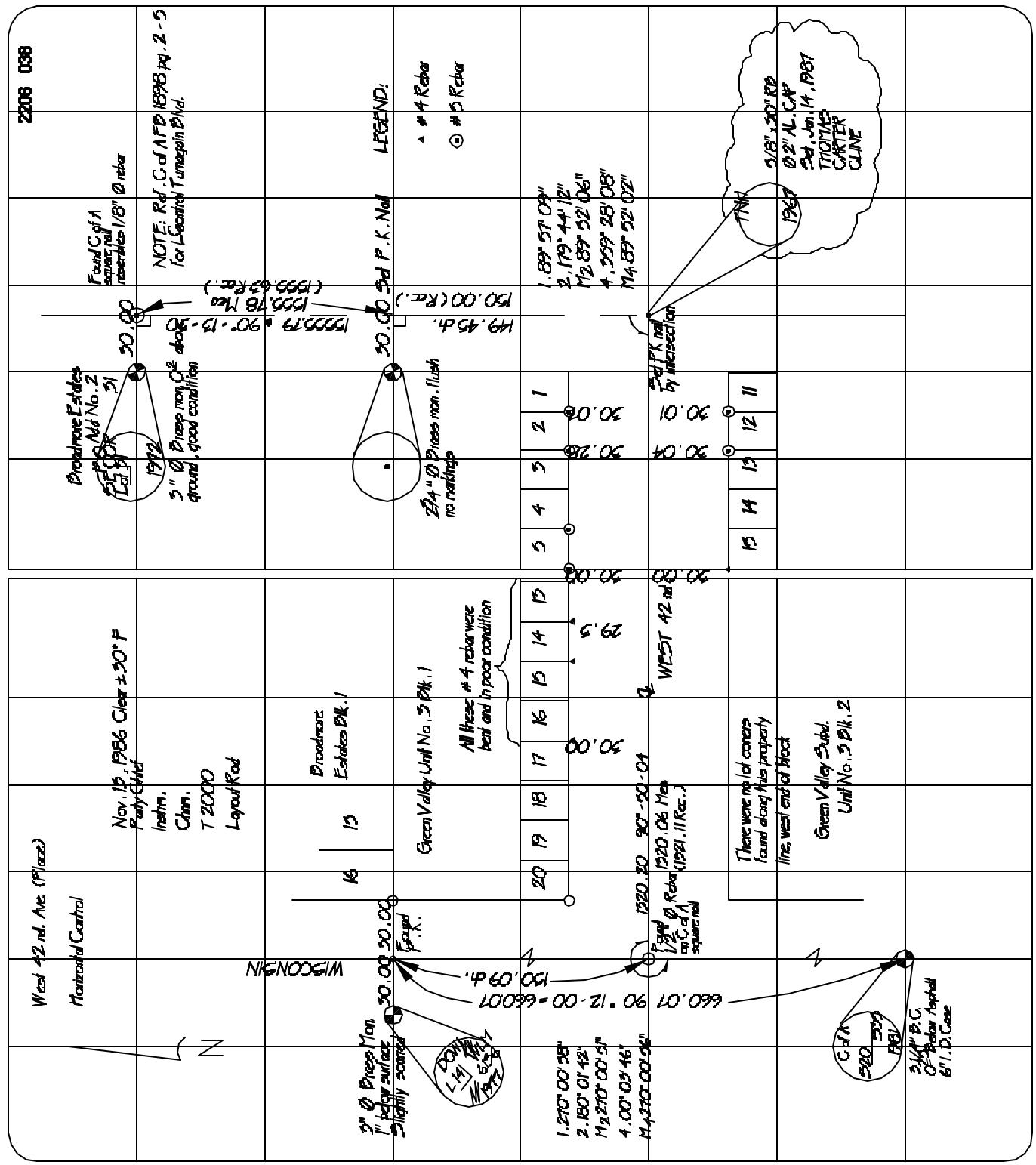

Sta	+	TBM LOOP FOR 100+AVE. TOPO Note: We post our level immediately before beginning this loop, check 25,000 in 400 Wild NA - 502261	ELEV.	TBM		DESCRIPTION	1865 86 Clear 20°F Party Chief Heath Roxie
TP	0.30	11 68 27 68	12.30 21 28				
TP	3.21	39 68 79 68	1.51 26 47				
TP	1.45	15 98 45 98	14.47 42 25				
TP	1.74	51 02 92 02	50 28 50 28				
TP	5.51	61 26 96 26	56 45 56 45				
GND 59	4.20	66.40 66 27	62 22 62 22	62.20		F.M. PC Man 18 W Road Bear Bldg.	
TP	7.11	66 27 66 27	59 26 59 26				
TP	3.79	61 25 61 25	57 26 57 26				
TP	0.02	67 00 67 00	66 98 66 98				
TP	0.23	71 22 71 22	77 09 77 09				
TP	6.50	82 20 82 20	76 40 76 40				
TN 15	5.03	81 88 81 88		76.85		F.M. PC Demand 11.5.00 per MOA BM Book Pg. 213	



SCALE:
NTS
APPROVED:
RAR
REVISED:
11/29/02

VERTICAL CONTROL

SECTION #
65.02
DETAIL #
65-4



SCALE:
NTS
APPROVED:
RAR
REVISED:
11/29/02

CLEARING LIMITS

SECTION #
65.02
DETAIL #
65-5

UNIVERSITY DRIVE STONE EXCAVATION LIMITS		EXCAVATION LIMITS (FROM L) C		2008 CB	
Station	LT.	RT.	Station	LT.	RT.
54+78 Begin Exc.	30	0	50+00	20	0
55+55	29	5	50+50	20	0
56+00	29	1	51+00	20	0
56+50	28	7	51+50	20	0
57+00	28	2	52+00	20	0
57+50	27	9	52+50	20	0
58+00	27	5	52+70 End Exc.	20	0
58+50	27	9			
58+63.2					
59+00	27	0			
59+15.2	27	0			
60+00	27	0			
61+00	27	0			
61+50	27	0			
62+00	25	6			
63+00	22	8			
64+00	20	0			
65+00	20	0			
66+00	20	0			
67+00	20	0			
68+00	20	0			
69+00	20	0			

5/16/86
Sunny 60°F
Party Chief
Chalm.
RT. Rise
100' Reg Tape



SCALE:
NTS
APPROVED:
RAR
REVISED:
11/29/02

X-SECTIONS/ SLOPE STAKES

SECTION #
65.02

DETAIL #
65-6

STA	X-SECTIONS BEFORE EXCAVATION/GRADE STAKES GOLDEN VIEW DR.	ELEV.	9-19-86 Party Chief Chairman Instructor	NI-2 Philly Rod Reag Tape			1988 15
26+00	$\begin{array}{r} 16 \\ 670 \end{array}$ $\begin{array}{r} 16 \\ 670 \end{array}$ $\begin{array}{r} 11 \\ 670 \end{array}$	$\begin{array}{r} 1 \\ 670 \end{array}$ $\begin{array}{r} 4 \\ 670 \end{array}$ $\begin{array}{r} 4 \\ 670 \end{array}$	$\begin{array}{r} 8 \\ 670 \end{array}$ $\begin{array}{r} 4 \\ 670 \end{array}$ $\begin{array}{r} 4 \\ 670 \end{array}$	$\begin{array}{r} 8 \\ 671 \end{array}$ $\begin{array}{r} 2 \\ 671 \end{array}$ $\begin{array}{r} 2 \\ 671 \end{array}$	$\begin{array}{r} 2 \\ 672 \end{array}$ $\begin{array}{r} 2 \\ 672 \end{array}$ $\begin{array}{r} 2 \\ 672 \end{array}$	$\begin{array}{r} 24 \\ 672 \end{array}$ $\begin{array}{r} 24 \\ 672 \end{array}$ $\begin{array}{r} 24 \\ 672 \end{array}$	$\begin{array}{r} 2 \\ 672 \end{array}$ $\begin{array}{r} 2 \\ 672 \end{array}$ $\begin{array}{r} 2 \\ 672 \end{array}$
Q Sub 67092	$\begin{array}{r} 30 \\ 670 \end{array}$ $\begin{array}{r} 0 \\ 670 \end{array}$ $\begin{array}{r} 1 \\ 670 \end{array}$	$\begin{array}{r} 15 \\ 670 \end{array}$	$\begin{array}{r} 10 \\ 670 \end{array}$	$\begin{array}{r} 10 \\ 671 \end{array}$	$\begin{array}{r} 24 \\ 671 \end{array}$	$\begin{array}{r} 26 \\ 671 \end{array}$	$\begin{array}{r} 26 \\ 671 \end{array}$
26+50	$\begin{array}{r} 8 \\ 674 \end{array}$ $\begin{array}{r} 2 \\ 674 \end{array}$ $\begin{array}{r} 2 \\ 674 \end{array}$	$\begin{array}{r} 2 \\ 674 \end{array}$ $\begin{array}{r} 2 \\ 674 \end{array}$ $\begin{array}{r} 2 \\ 674 \end{array}$	$\begin{array}{r} 2 \\ 674 \end{array}$ $\begin{array}{r} 2 \\ 674 \end{array}$ $\begin{array}{r} 2 \\ 674 \end{array}$	$\begin{array}{r} 2 \\ 674 \end{array}$ $\begin{array}{r} 2 \\ 674 \end{array}$ $\begin{array}{r} 2 \\ 674 \end{array}$	$\begin{array}{r} 2 \\ 674 \end{array}$ $\begin{array}{r} 2 \\ 674 \end{array}$ $\begin{array}{r} 2 \\ 674 \end{array}$	$\begin{array}{r} 2 \\ 674 \end{array}$ $\begin{array}{r} 2 \\ 674 \end{array}$ $\begin{array}{r} 2 \\ 674 \end{array}$	$\begin{array}{r} 2 \\ 674 \end{array}$ $\begin{array}{r} 2 \\ 674 \end{array}$ $\begin{array}{r} 2 \\ 674 \end{array}$
Q Sub 67520	$\begin{array}{r} 12 \\ 675 \end{array}$ $\begin{array}{r} 2 \\ 675 \end{array}$ $\begin{array}{r} 2 \\ 675 \end{array}$	$\begin{array}{r} 26 \\ 675 \end{array}$	$\begin{array}{r} 10 \\ 675 \end{array}$	$\begin{array}{r} 11 \\ 675 \end{array}$	$\begin{array}{r} 25 \\ 675 \end{array}$	$\begin{array}{r} 25 \\ 675 \end{array}$	$\begin{array}{r} 25 \\ 675 \end{array}$
TP	$\begin{array}{r} 205 \\ 677 \end{array}$ $\begin{array}{r} 205 \\ 687 \end{array}$	$\begin{array}{r} 1186 \\ 675 \end{array}$	$\begin{array}{r} 675 \end{array}$				

CULVERT BY TAKES Eagle River Rd.		1888 71
Party Chnl 1/2 in Chm.	5-13-85 WIND III 25' Glass Rod 100' Chain	Clay
STA	+	HI
		ELEV.
TRM	489.42	808
		481.34
		Rec. 481.35
		N. Rim Mt of NW cor. E. R. Ry & Wildwood Page 60
		Exist. Ditch d'outlet
		Exist. Ditch Platton 4 S 2
		RP (10) S
		RP (10) N
		RP / Hub (10)
		RP / Hub
		RP / Hub



II 81
3' Chain



SCALE:
NTS
APPROVED:
RAR
REVISED:
11/29/02

DRAINAGE STRUCTURES

SECTION #
65.02
DETAIL #
65-8

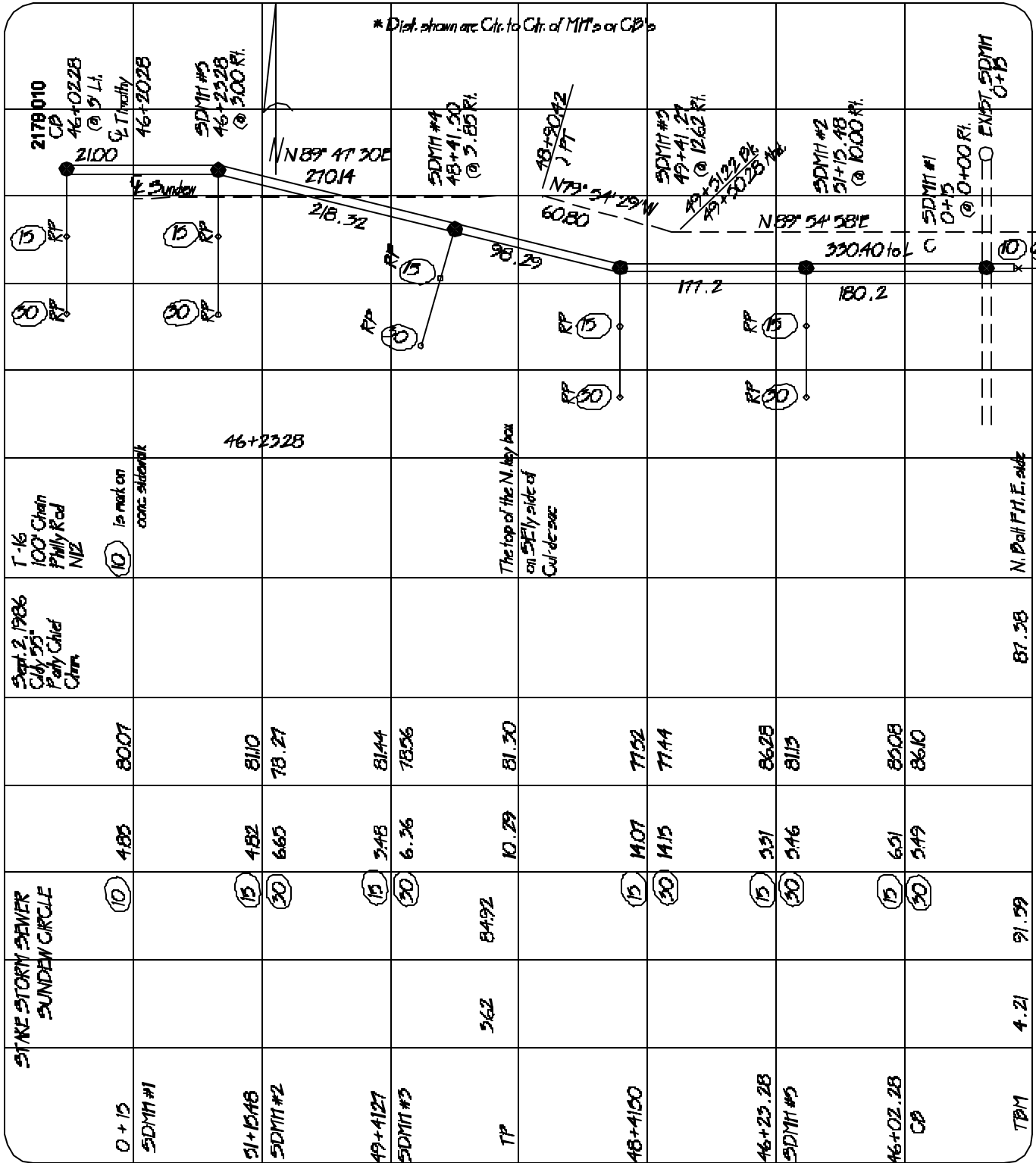

* Dist. shown are Ctr. to Ctr. of MH's or CP's



SCALE:
NTS
APPROVED:
RAR
REVISED:
11/29/02

STORM SEWER LAYOUT

SECTION #
65.02
DETAIL #
65-10

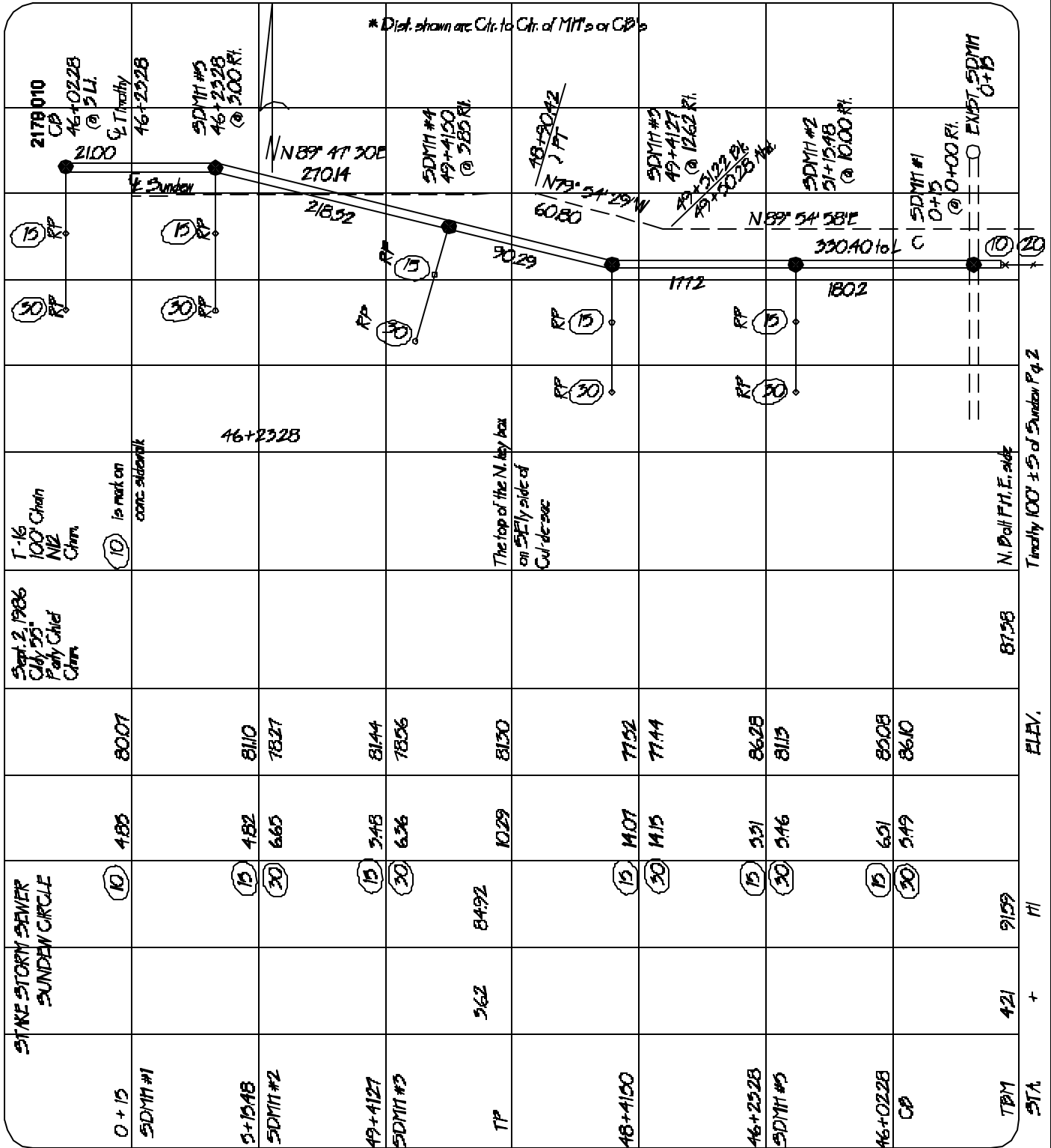

SCALE:
NTS
APPROVED:
RAR
REVISED:
11/29/02

DRAINAGE STAKES

SECTION #
65.02
DETAIL #
65-11

STAKE STORY SEWER SUNDEN CIRCLE	STAKE #	ELEV.	STATIONING	DESCRIPTION
	10	8007	0+15	SDMH #1
	15	8110	5+15.48	SDMH #2
	30	7827	6+65	SDMH #3
	15	8144	7+48	SDMH #4
	30	7806	8+36	SDMH #5
		8130	10+29	TP
	15	7152	14+01	SDMH #1
	30	7144	14+15	SDMH #2
	15	8628	15+31	SDMH #3
	30	8115	16+16	SDMH #4
	15	8508	16+21	SDMH #5
	30	8610	17+19	SDMH #6
				TPM
				STA

Tie to 100' ± S of Sunden Pg. 2

ELEV.

11

+

11

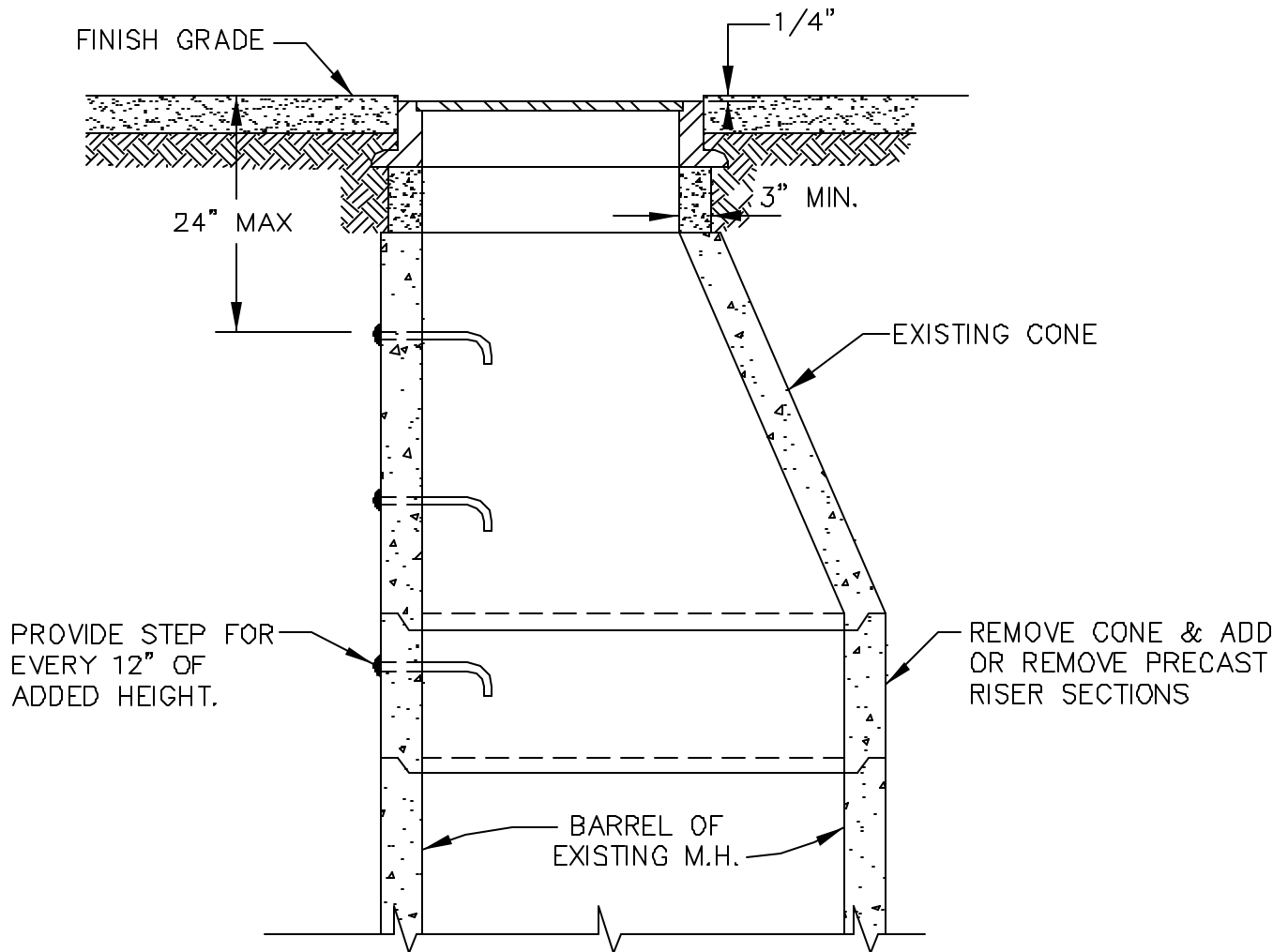

NOTES:

1. ALL PERTINENT SECTIONS OF THE STANDARD SPECIFICATIONS WILL APPLY.
2. RESET RING IN FULL BED OF MORTAR.
3. REFER TO ASTM DESIGNATION C-478-69 FOR DESIGN AND STRENGTH REQUIREMENTS.
4. RESET CONE IN RAM-NEK OR EQUAL.
5. WRAP ALL JOINTS WITH ESKY WRAP OR MIRADRI, OR APPROVED EQUAL



SCALE:
NTS
APPROVED:
RAR
REVISED:
11/29/02

MANHOLE CONE ADJUSTMENT

SECTION#
70.02
DETAIL #
70-1

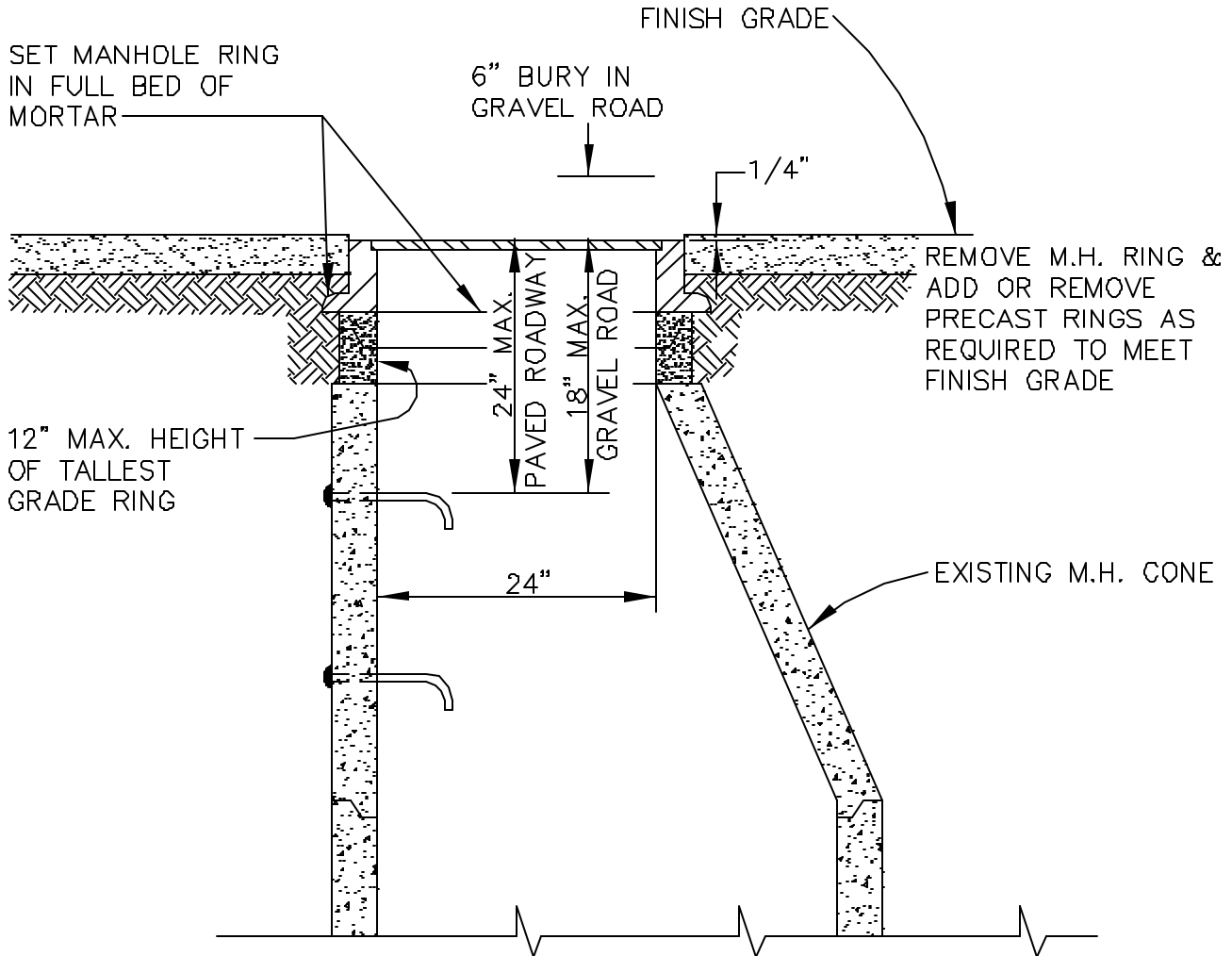

SET MANHOLE RING
IN FULL BED OF
MORTAR

6" BURY IN
GRAVEL ROAD

FINISH GRADE

1/4"

REMOVE M.H. RING &
ADD OR REMOVE
PRECAST RINGS AS
REQUIRED TO MEET
FINISH GRADE

12" MAX. HEIGHT
OF TALLEST
GRADE RING

24" MAX.
PAVED ROADWAY

18" MAX.
GRAVEL ROAD

24"

EXISTING M.H. CONE

NOTES:

1. ALL PERTINENT SECTIONS OF THE STANDARD SPEC. WILL APPLY.
2. REFER TO ASTM DESIGNATION C-478-69 FOR DESIGN AND STRENGTH REQUIREMENTS.
3. WHEN AN ADJUSTMENT REQUIRES MORE THAN 12" IN GRADE RINGS, A CONE ADJUSTMENT SHALL BE MADE.



SCALE:
NTS
APPROVED:
RAR
REVISED:
11/29/02

MANHOLE RING ADJUSTMENT

SECTION#
70.03
DETAIL #
70-2

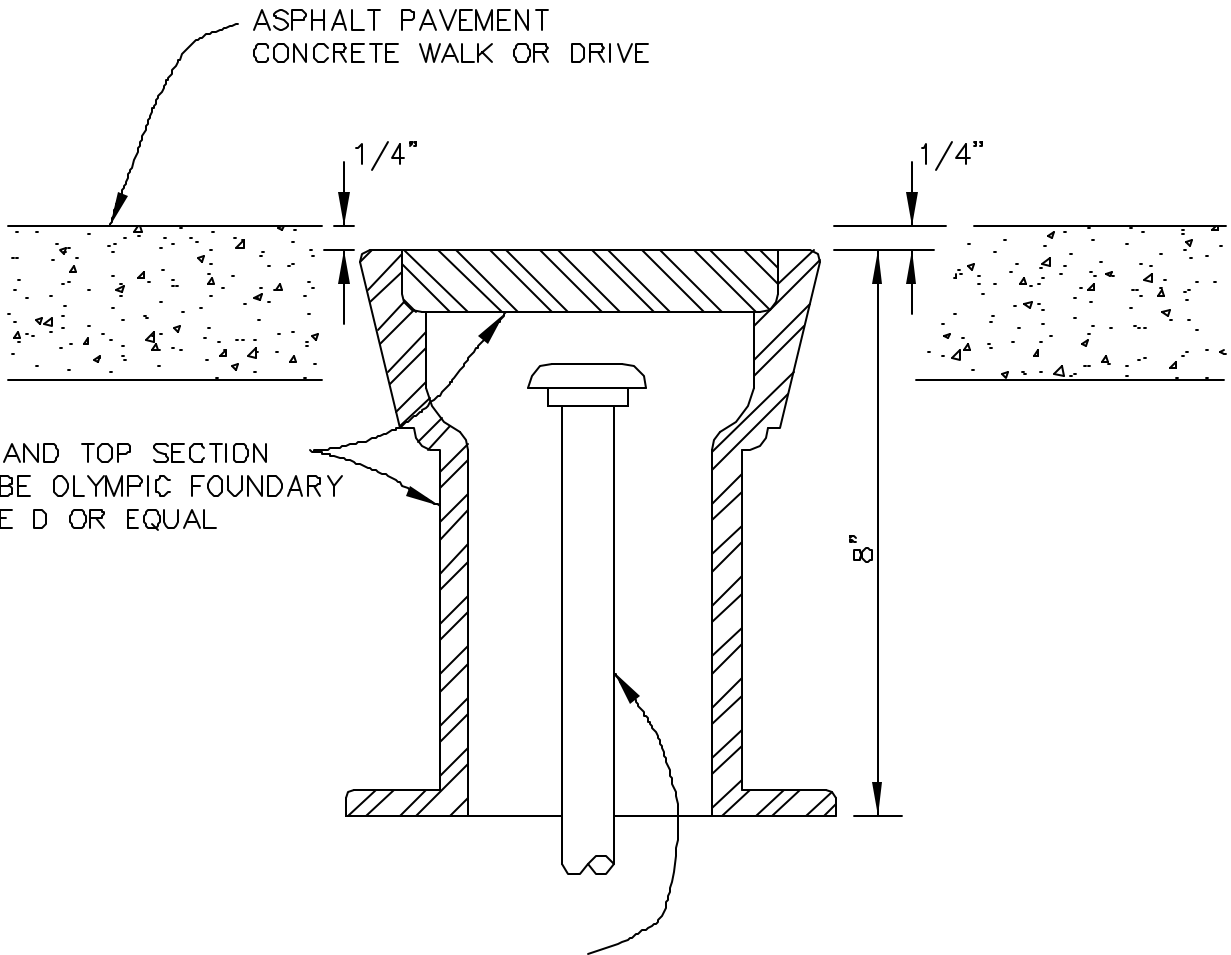

STANDARD VALVE BOX

NOTE:

TYPICAL INSTALLATION WHEN VALVE BOX FALLS WITHIN
ASPHALT PAVEMENT, CONCRETE WALK OR DRIVE.



SCALE:
NTS
APPROVED:
RAR
REVISED:
11/29/02

ADJUST SERVICE VALVE BOX

SECTION #
70.09
DETAIL #
70-3

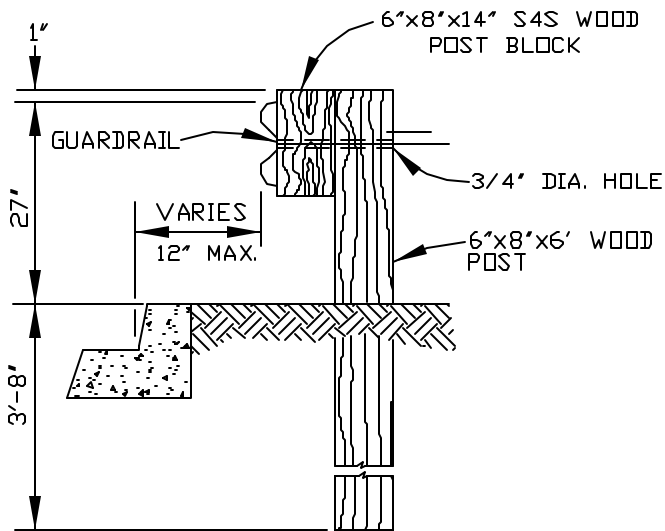
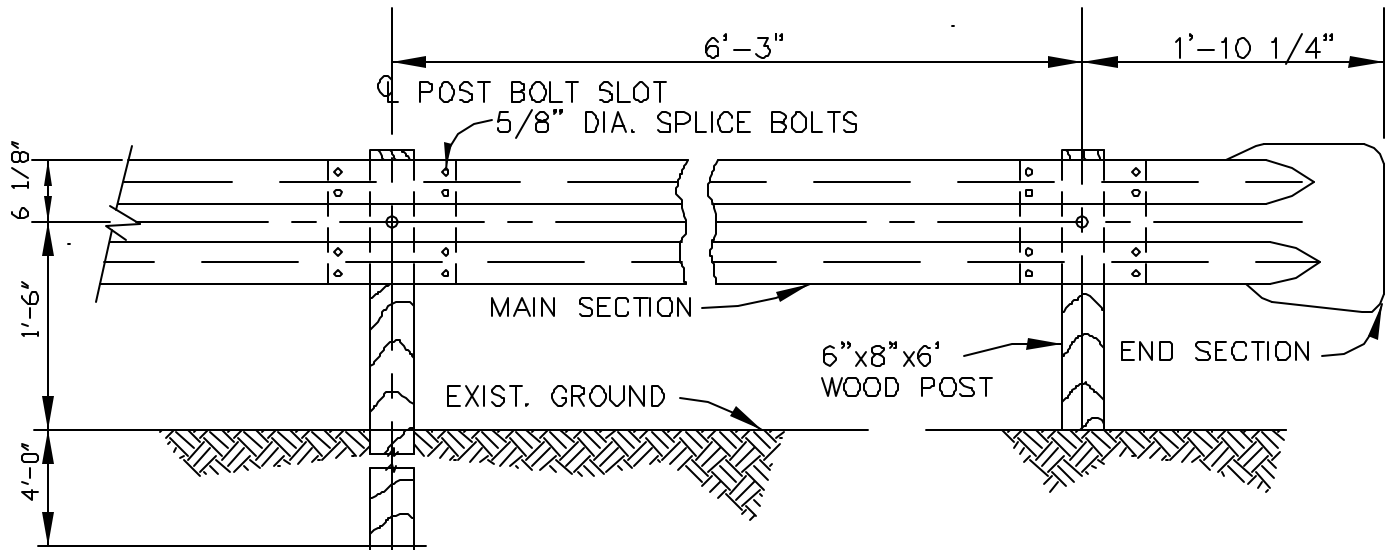

WOOD POST

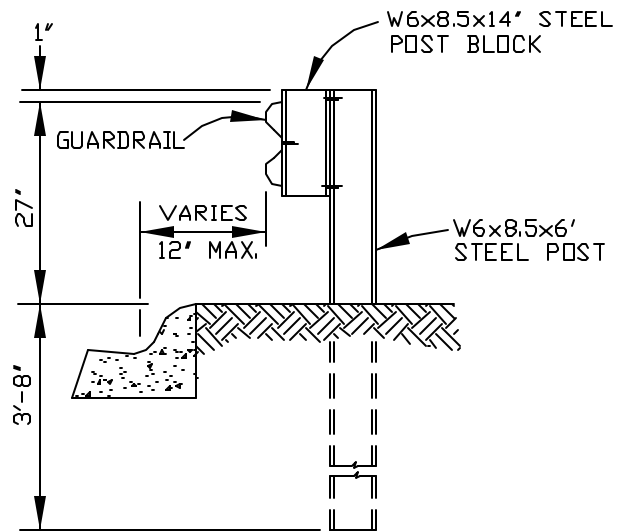

STEEL POST

NOTES:

1. GUARD RAIL SHALL BE ARMCO FLEXBEAM OR ECONOBEAM OR EQUAL DEPENDING ON GAUGE AS SPECIFIED IN THE BID PROPOSAL.
2. MEASUREMENT OF GUARD RAIL WILL BE PER LINEAL FOOT ALONG THE FACE OF RAIL, INCLUDING END SECTIONS.
3. SEE STATE OF ALASKA DOT/PF STANDARD DETAIL G-12.00 FOR G2S GUARD-RAIL TRANSITION AT BRIDGES.



SCALE:
NTS
APPROVED:
RAR
REVISED:
11/29/02

GUARDRAIL DETAIL

SECTION #
70.13
DETAIL #
70-4

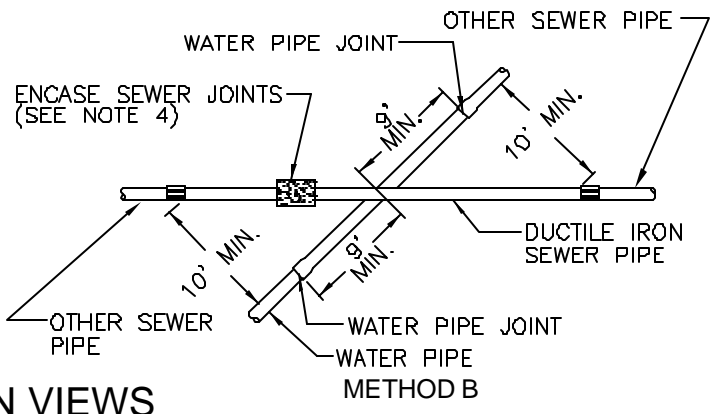
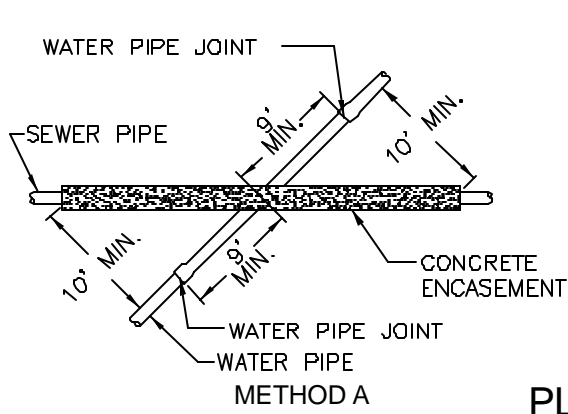

PLAN VIEWS

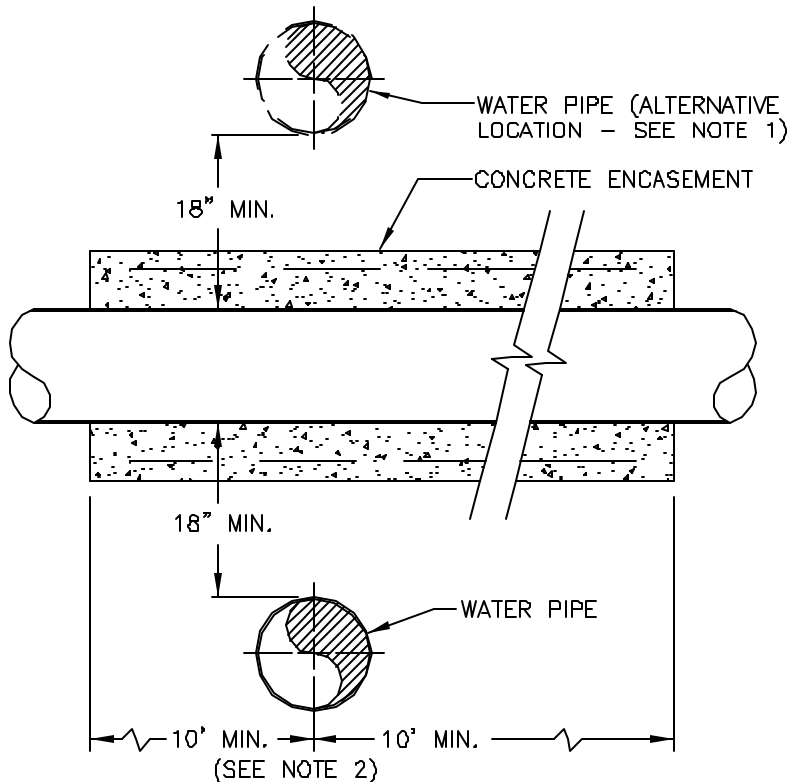

METHOD A
ELEVATION VIEW

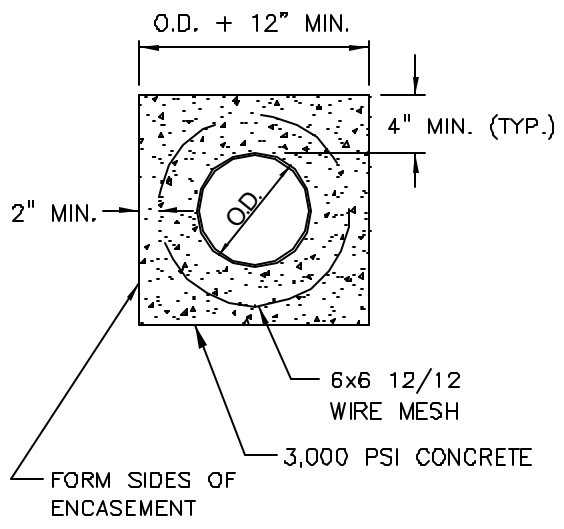

METHODS A & B
TYPICAL SECTION

NOTES:

1. IF SEWER MAIN IS ABOVE WATER MAIN, ENCASE SEWER MAIN AS DIRECTED BY THE ENGINEER.
2. A FULL LENGTH OF WATER PIPE SHALL BE CENTERED UNDER THE SANITARY SEWER CROSSING.
3. ON OBLIQUE CROSSINGS, THE TEN FOOT MEASUREMENT SHALL BE TAKEN PERPENDICULAR TO THE WATER PIPE.
4. FOR METHOD B, SEWER PIPE SHALL BE DUCTILE IRON PIPE FOR THE LENGTH SHOWN, AND ANY JOINTS SHALL BE ENCASED FOR A MINIMUM OF 18" ON EITHER SIDE OF THE JOINT.
5. ALTERNATIVE ENCASEMENT METHODS MAY BE USED SUCH AS HEAT SHRINK SEAL IF APPROVED BY THE ENGINEER.



SCALE:
NTS
APPROVED:
RAR
REVISED:
11/29/02

SANITARY SEWER
ENCASEMENT

SECTION#
70.14
DETAIL #
70-5

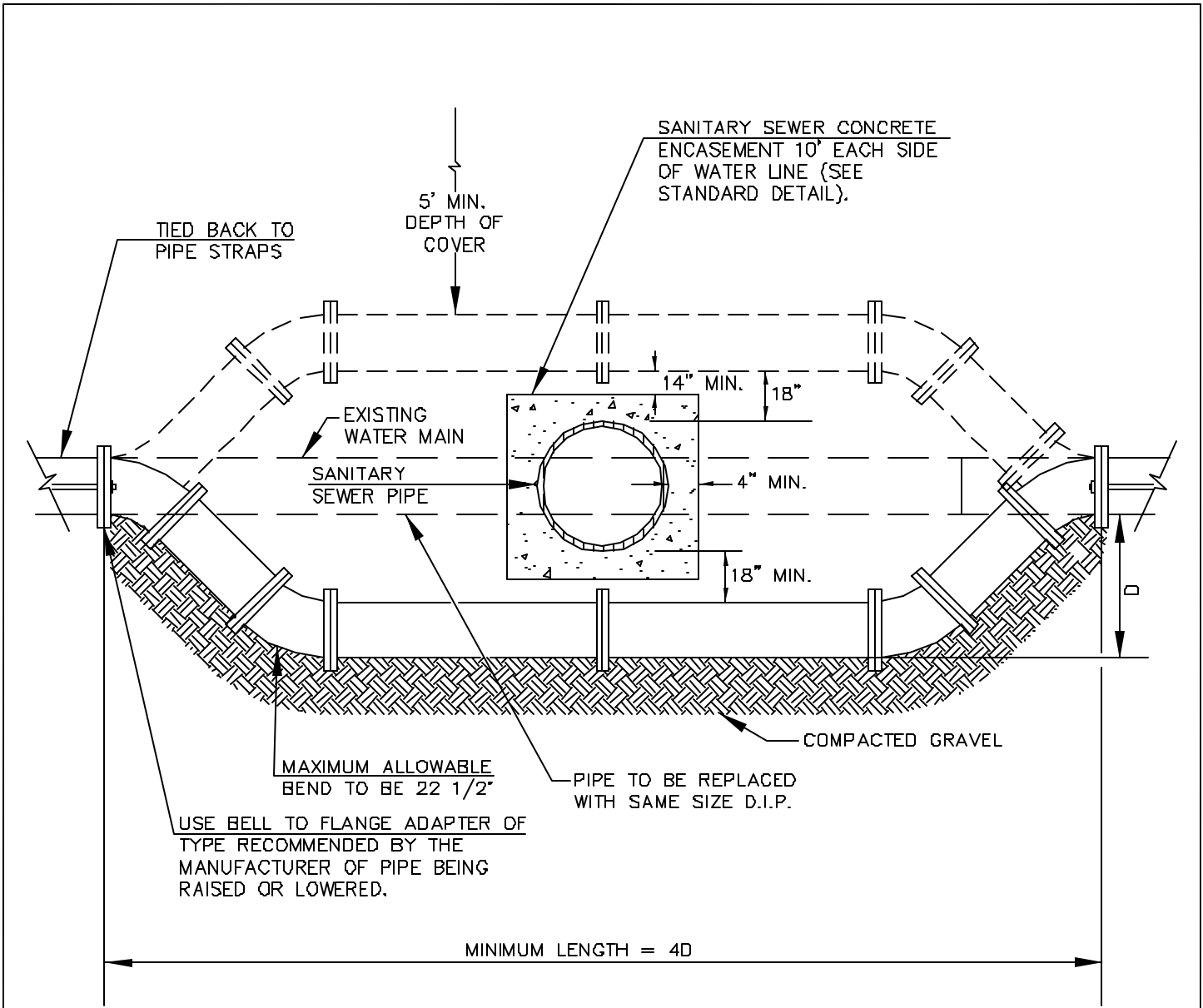

NOTE: ALL JOINTS TO BE TIED TOGETHER WITH RESTRAINED JOINT PIPE FITTINGS— MEGA-LUG OR EQUAL



SCALE:
NTS
APPROVED:
RAR
REVISED:
11/29/02

RELOCATE WATER MAIN (SANITARY SEWER)

SECTION #
70.15

DETAIL #
70-7

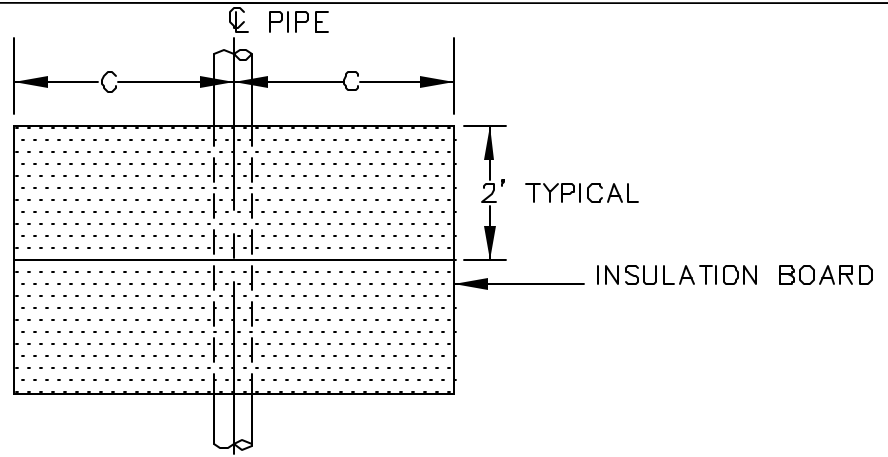

PLAN VIEW

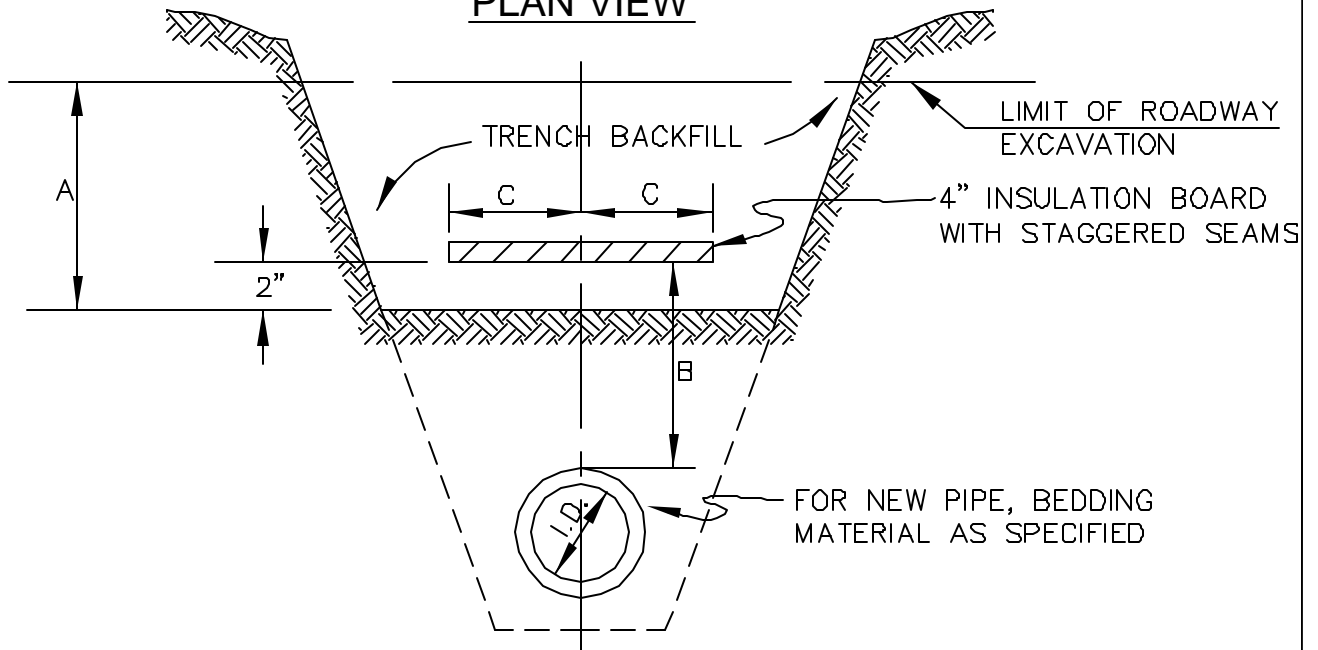

PROFILE VIEW

B*	C			
	NEW MAIN	EXISTING MAIN	NEW SERVICE CON.	EXISTING SERVICE CON.
1'	2'		1'	
1' to 3'		2'		2'
3' to 5'		3'		3'
5' to 7'		4'		4'

* AS NOTED ON PLANS

A= DEPTH FOR PAYMENT UNDER "TRENCH EXCAVATION AND BACKFILL" WHERE INSULATION IS PLACED OVER EXISTING PIPE

NOTES:

1. THIS DETAIL APPLIES ONLY WHERE INSULATION IS REQUIRED BY THE PLANS.
2. MAXIMUM I.D. = 12"



SCALE:
NTS
APPROVED:
RAR
REVISED:
11/29/02

PIPE INSULATION

SECTION#
70.16
DETAIL #
70-8

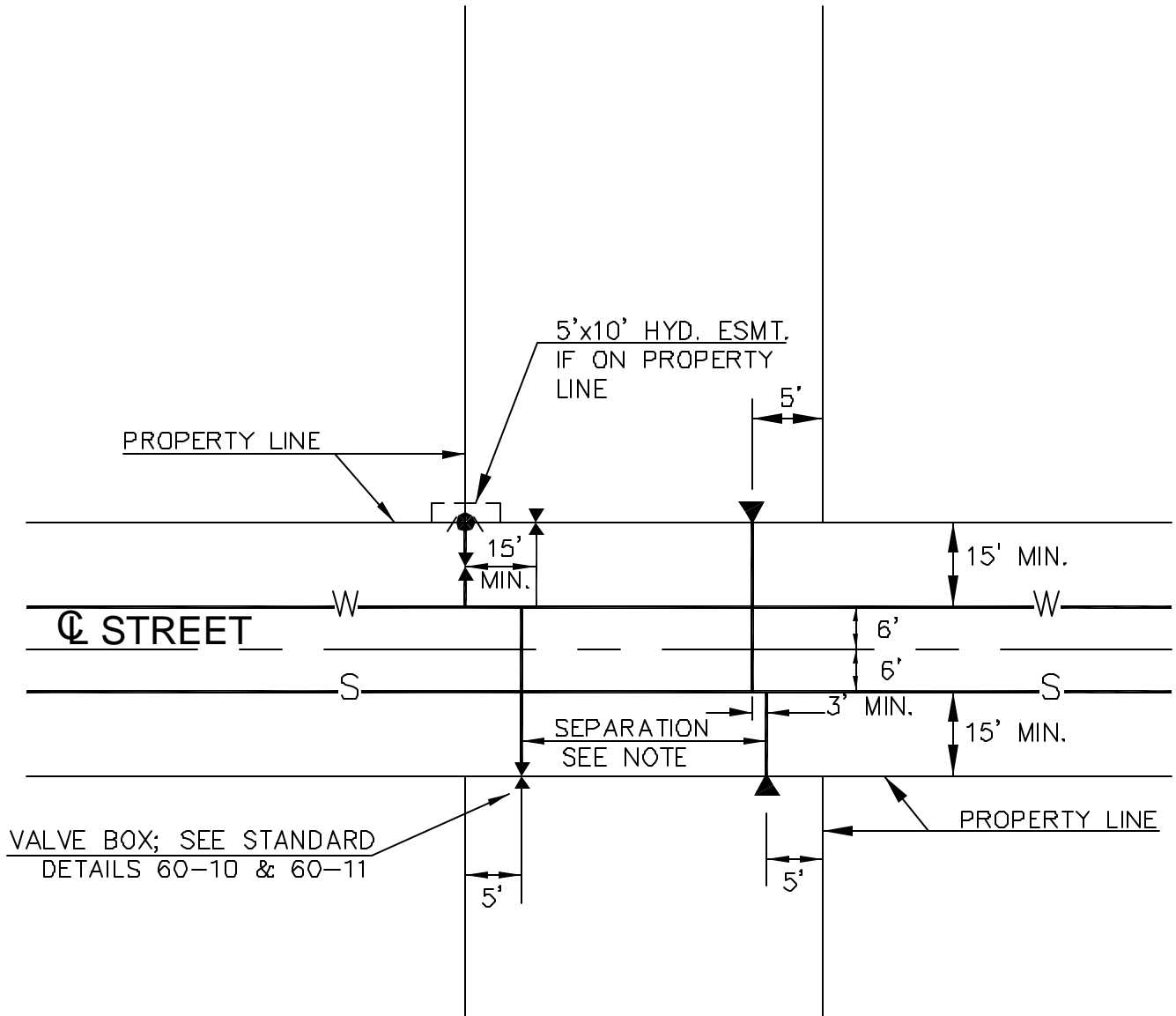

NOTE:

3' MIN. SEPARATION FOR PRIVATE SERVICES, 10' MIN. SEPARATION FOR PUBLIC SERVICES AS DEFINED BY ALASKA DEPARTMENT OF ENVIRONMENTAL CONSERVATION.



SCALE:
NTS
APPROVED:
RAR
REVISED:
11/29/02

TYPICAL WATER AND SEWER LOCATIONS

SECTION #
MISC.

DETAIL #
70-9

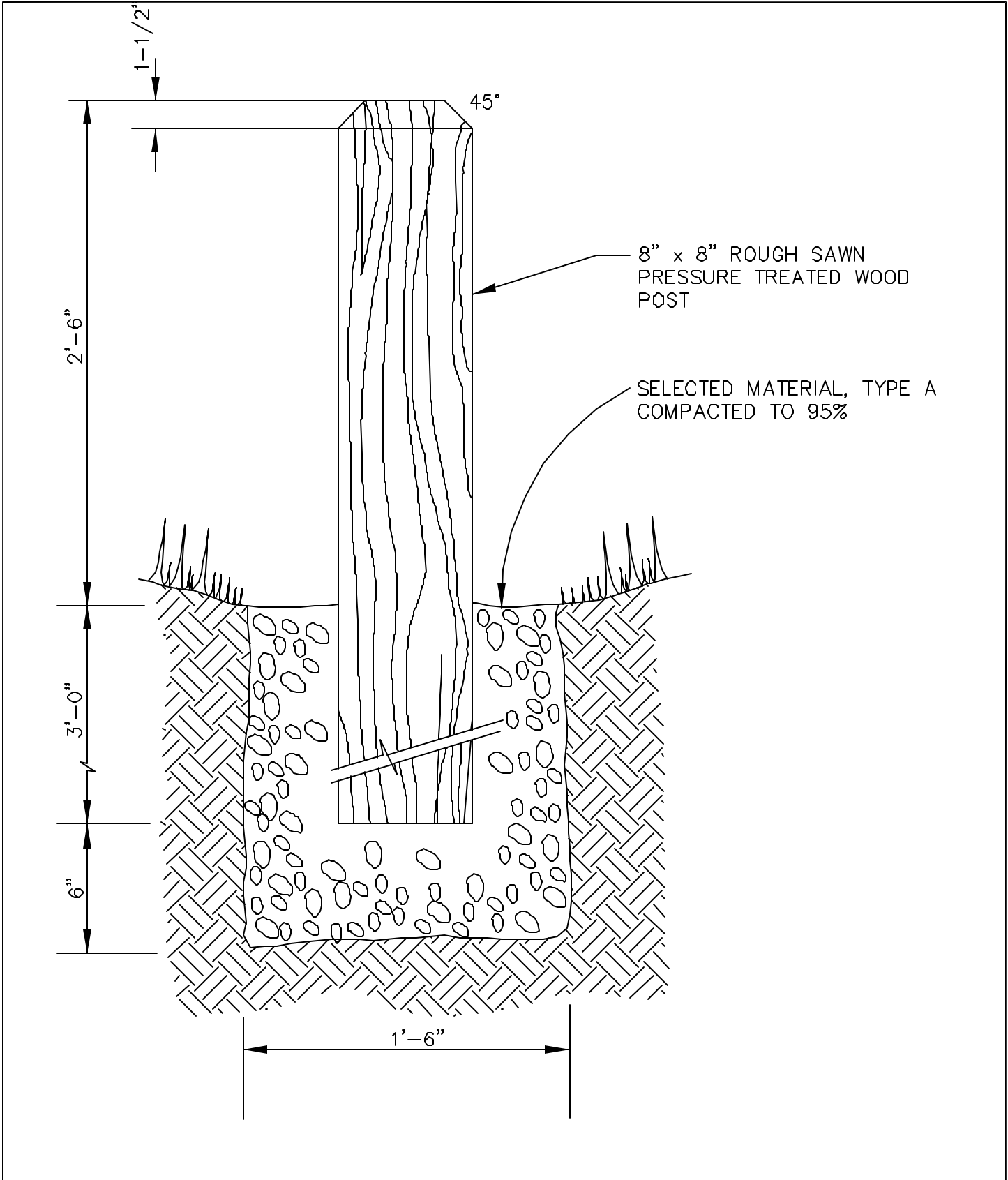

SCALE:
NTS
APPROVED:
RAR
REVISED:
11/29/02

SOLID BOLLARD

SECTION#
MISC.

DETAIL #
70-10

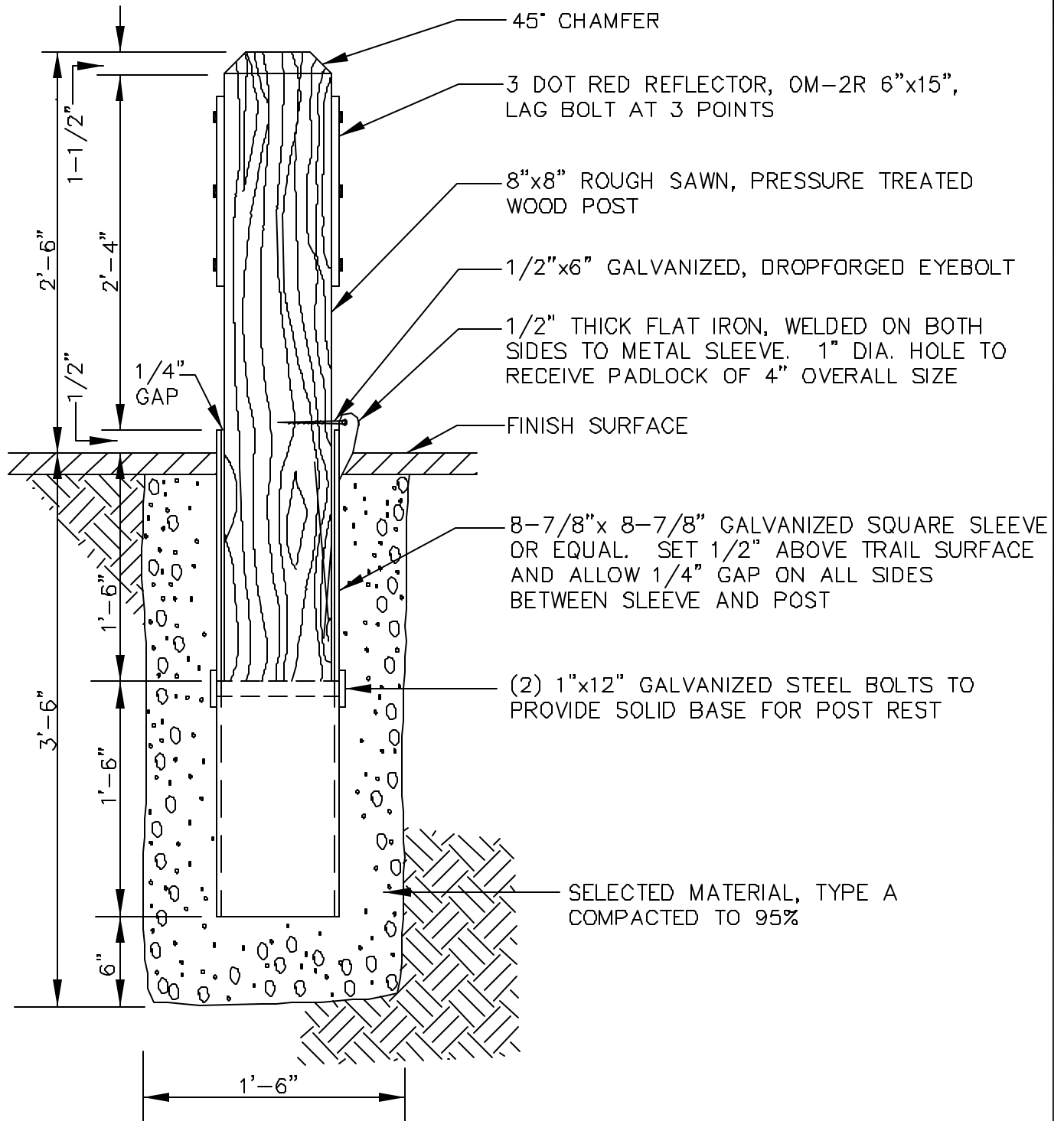

NOTE:

- PADLOCK SHOULD BE LOCATED OUT OF TRAFFIC FLOW. PADLOCK PROVIDED BY PARK MAINTENANCE CREW.



SCALE:
NTS
APPROVED:
RAR
REVISED:
11/29/02

REMOVABLE BOLLARD

SECTION#
MISC.

DETAIL #
70-11

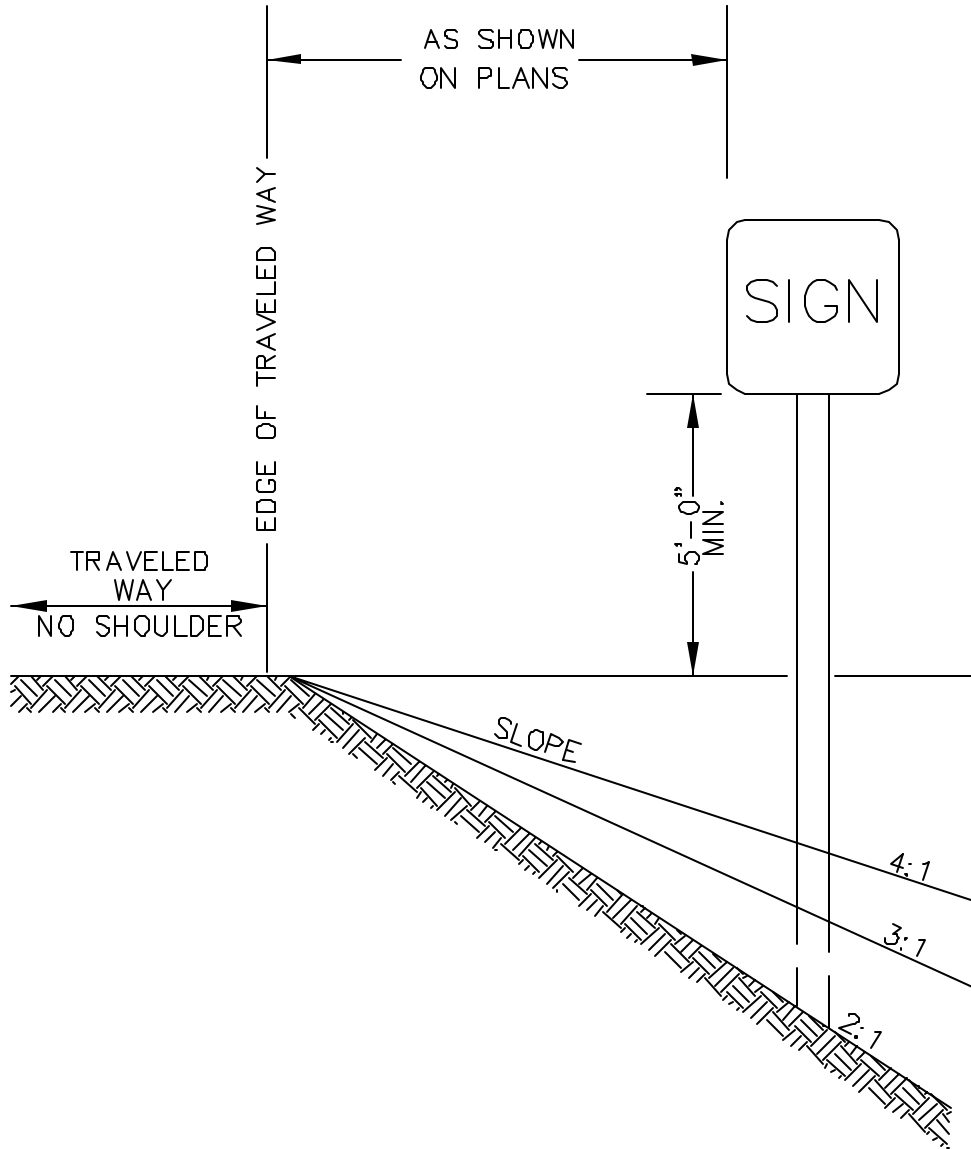

SCALE:
NTS
APPROVED:
RAR
REVISED:
11/29/02

SIGN PLACEMENT NO CURB OR SHOULDER

SECTION #
70.18
DETAIL #
70-12

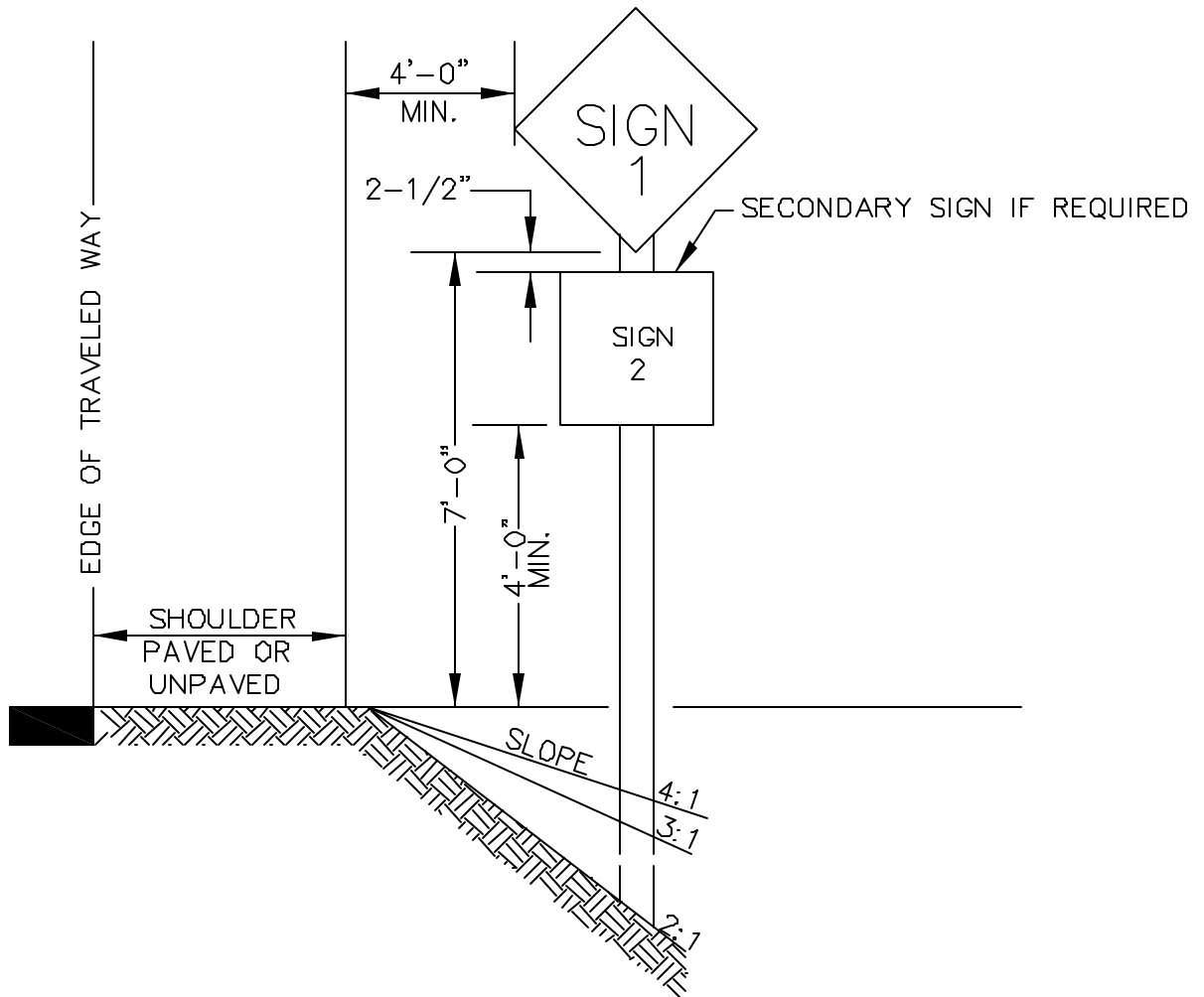

SCALE:
NTS
APPROVED:
RAR
REVISED:
11/29/02

SIGN PLACEMENT SHOULDER WITHOUT CURB

SECTION #
70.18
DETAIL #
70-13

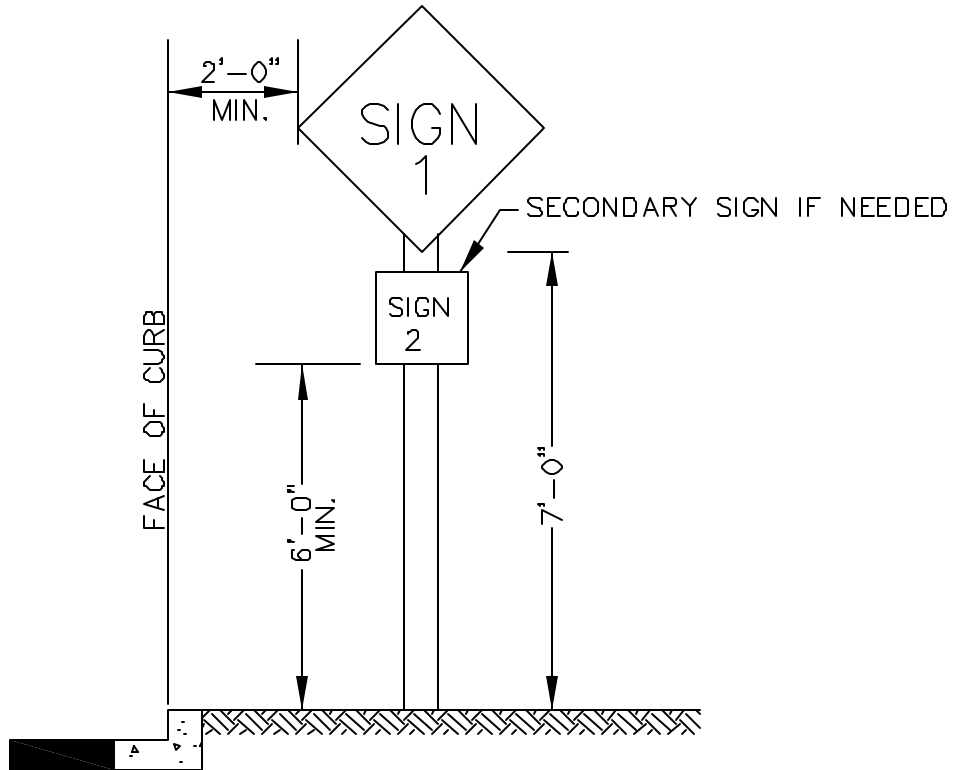

SCALE:
NTS
APPROVED:
RAR
REVISED:
11/29/02

SIGN PLACEMENT CURB WITHOUT SIDEWALK

SECTION #
70.18
DETAIL #
70-14

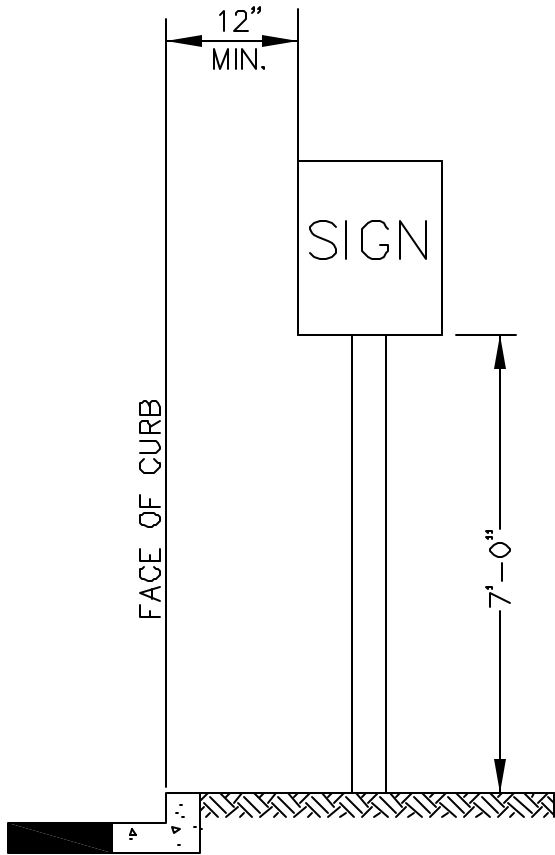

SCALE:
NTS
APPROVED:
RAR
REVISED:
11/29/02

SIGN PLACEMENT CURB WITH SIDEWALK

SECTION #
70.18
DETAIL #
70-15

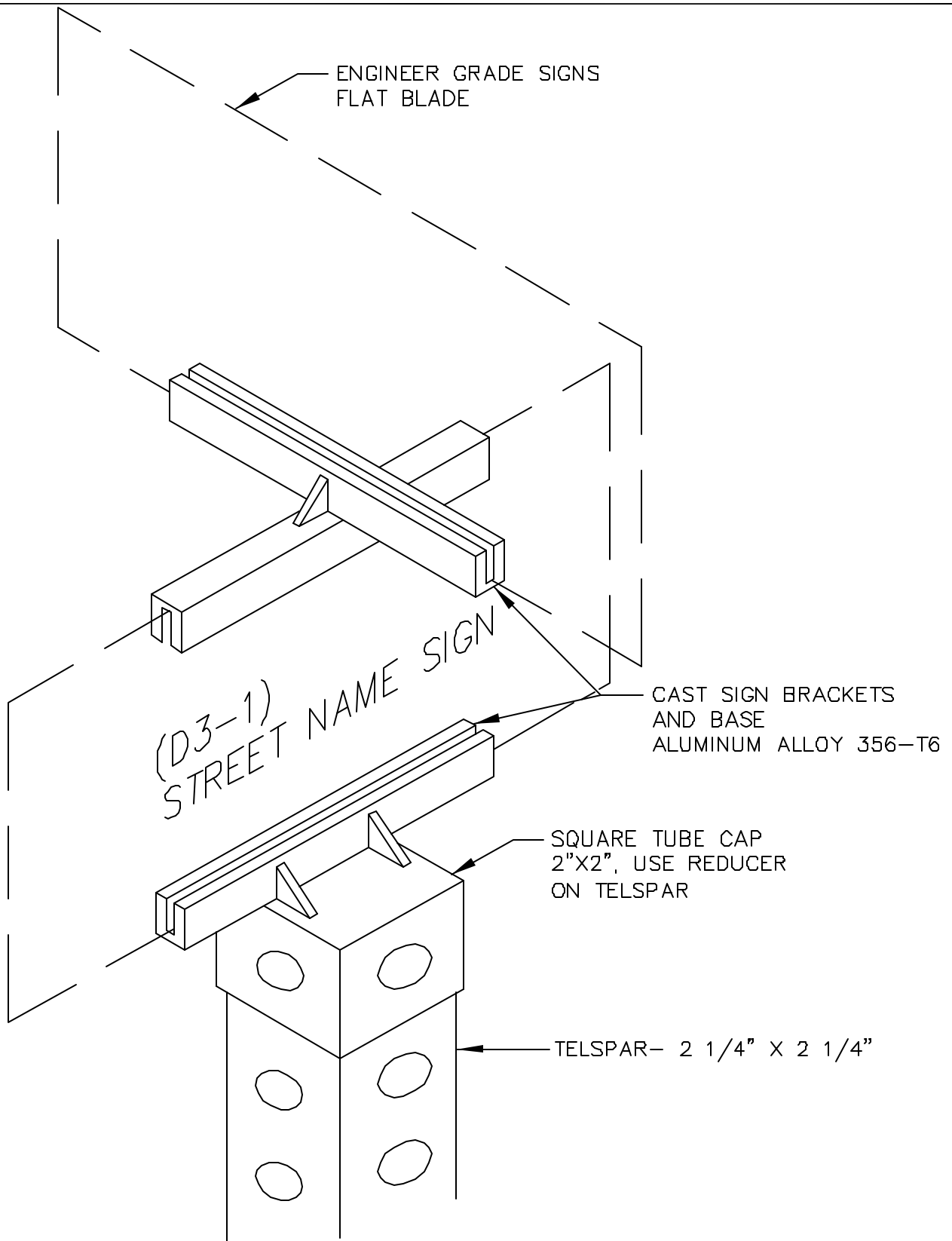

SCALE:
NTS
APPROVED:
RAR
REVISED:
11/29/02

STREET NAME SIGNS

SECTION #
70.18
DETAIL #
70-16

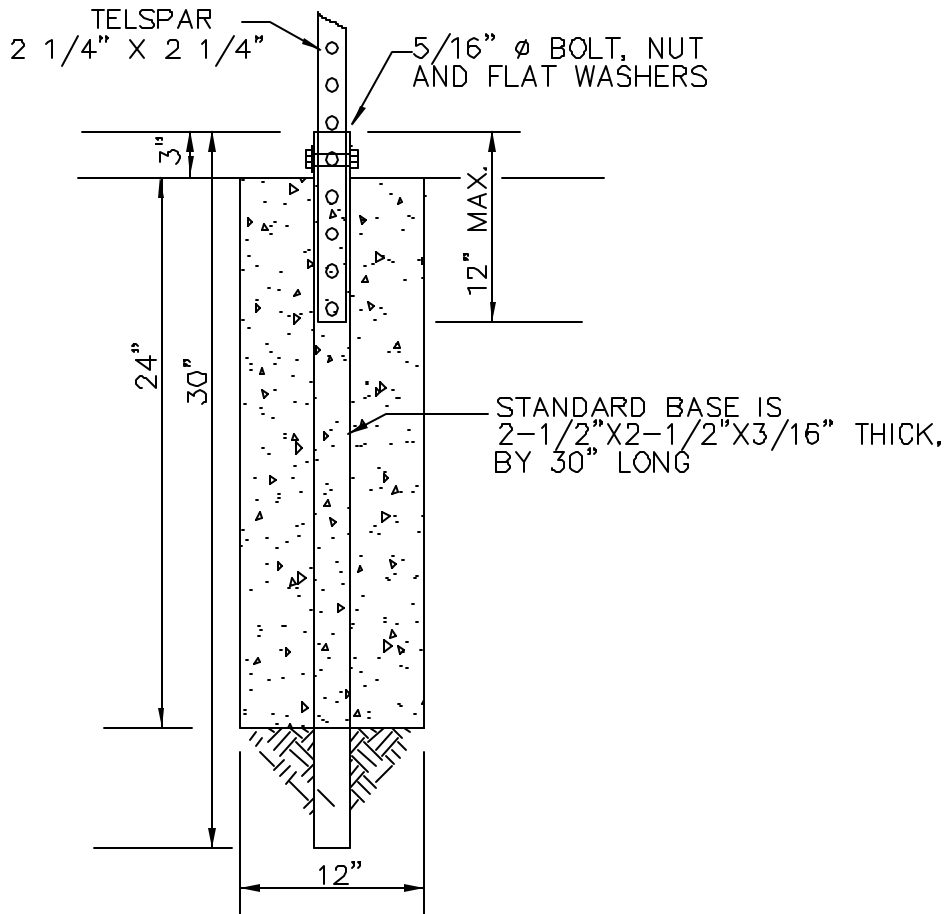

SCALE:
NTS
APPROVED:
RAR
REVISED:
11/29/02

CONCRETE FOUNDATION FOR SIGN POST

SECTION#
70.18
DETAIL #
70-17

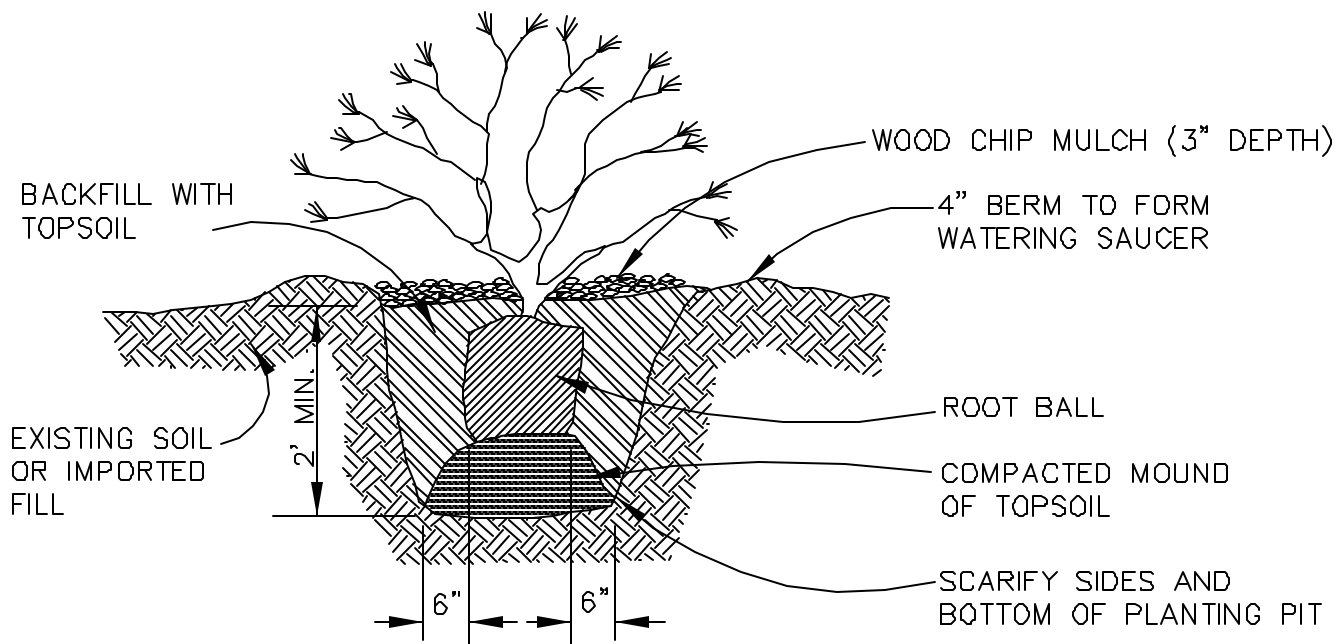

SCALE:
 NTS
 APPROVED:
 RAR
 REVISED:
 11/29/02

SHRUB PLANTING DETAIL

SECTION#
 75.02
 DETAIL #
 75-1

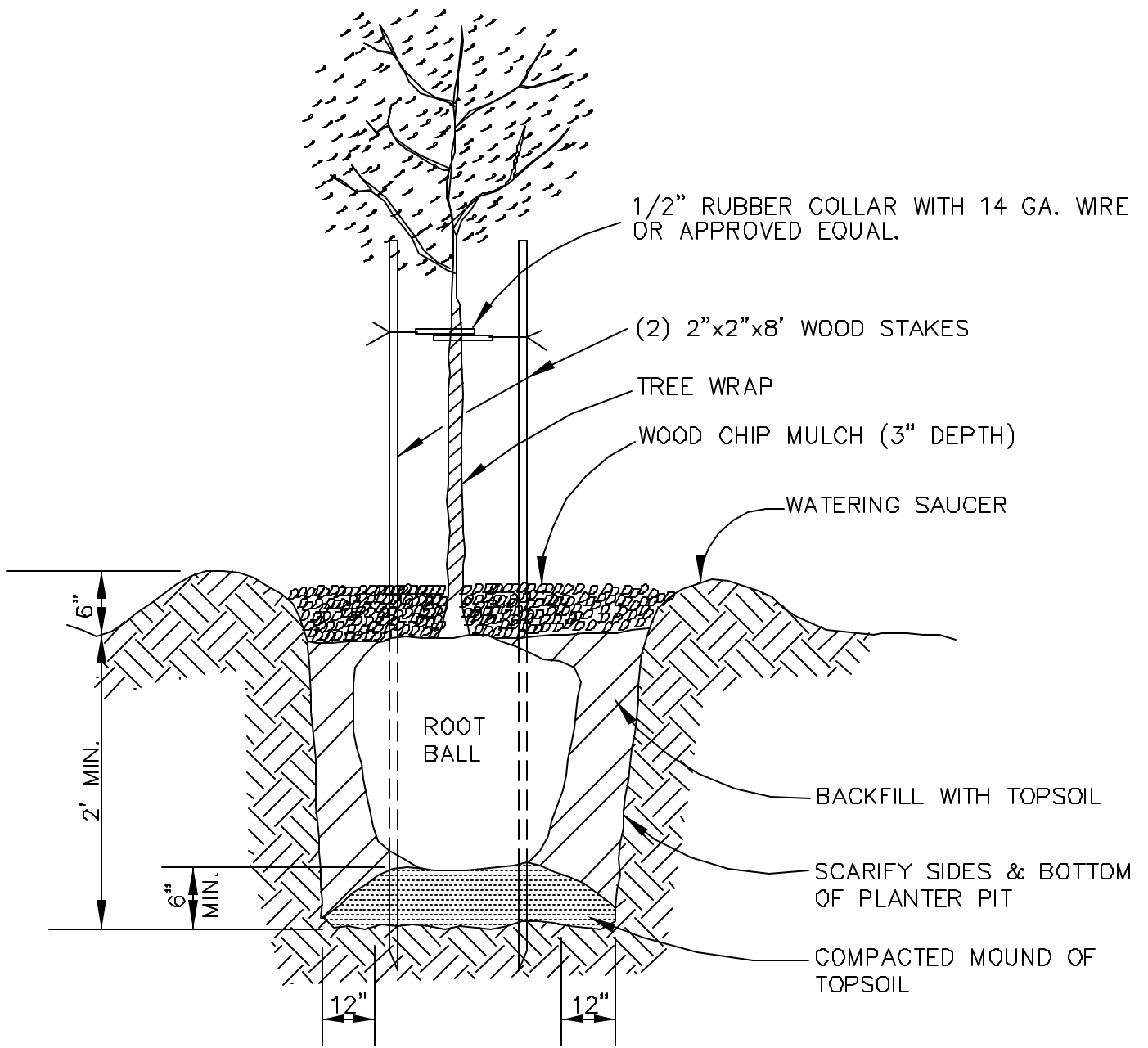

NOTES:

1. WRAP TREES FROM GROUND TO FIRST BRANCH USING "TREE WRAP" OR APPROVED EQUAL.
2. IF ROOTBALL IS B & B, REMOVE BURLAP FROM TOP OF ROOTBALL.
3. DO NOT PENETRATE ROOTBALL WITH TREE STAKES.



SCALE:
NTS
APPROVED:
RAR
REVISED:
11/29/02

DECIDUOUS TREE PLANTING DETAIL

SECTION#
75.02

DETAIL #
75-2

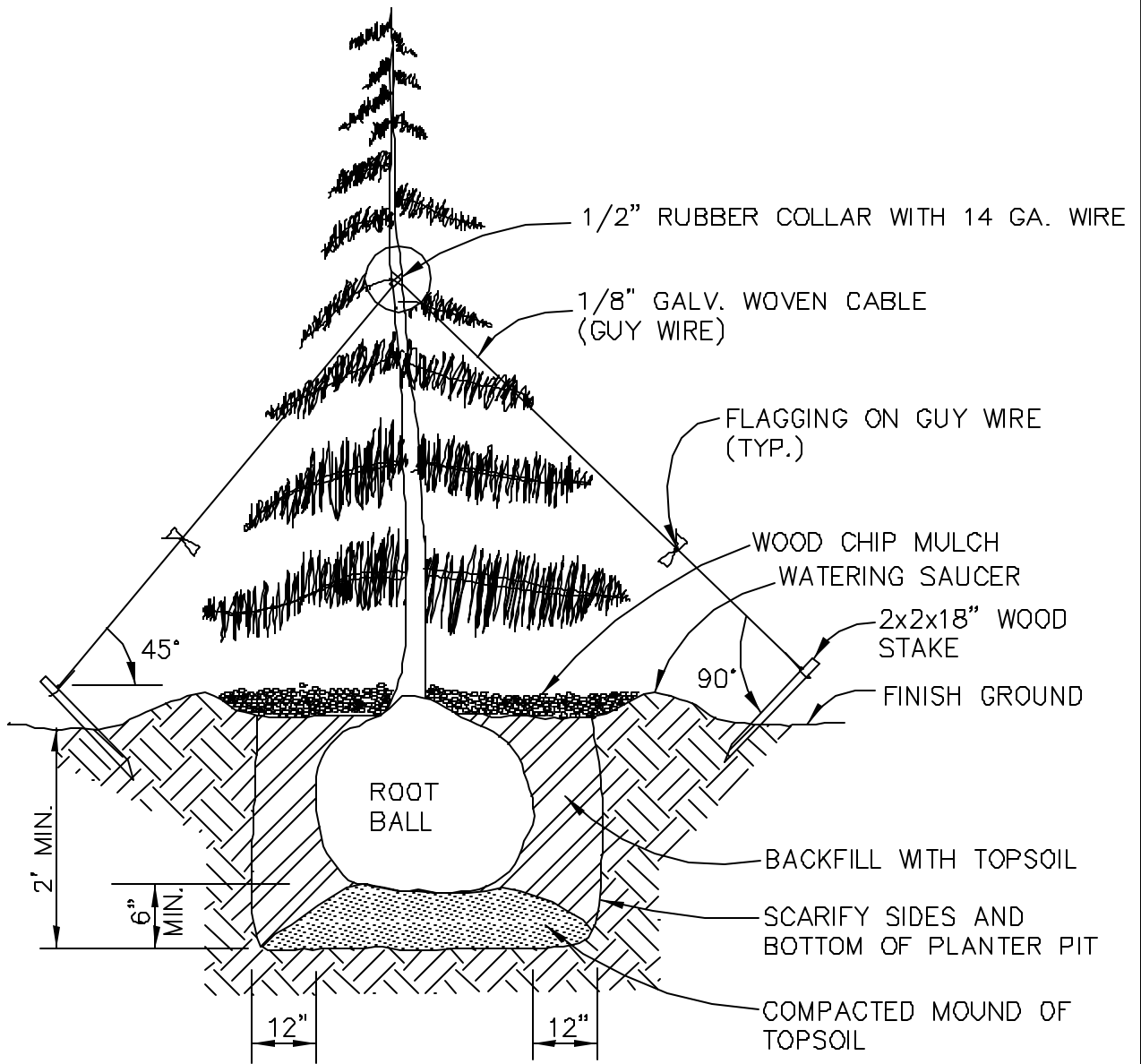

NOTES

1. SPACE THREE (3) GUYS EQUALLY AROUND TREE.
2. DO NOT PENETRATE ROOT BALL WITH STAKES.



SCALE:
NTS
APPROVED:
RAR
REVISED:
11/29/02

CONIFER PLANTING DETAIL

SECTION #
75.02

DETAIL #
75-3

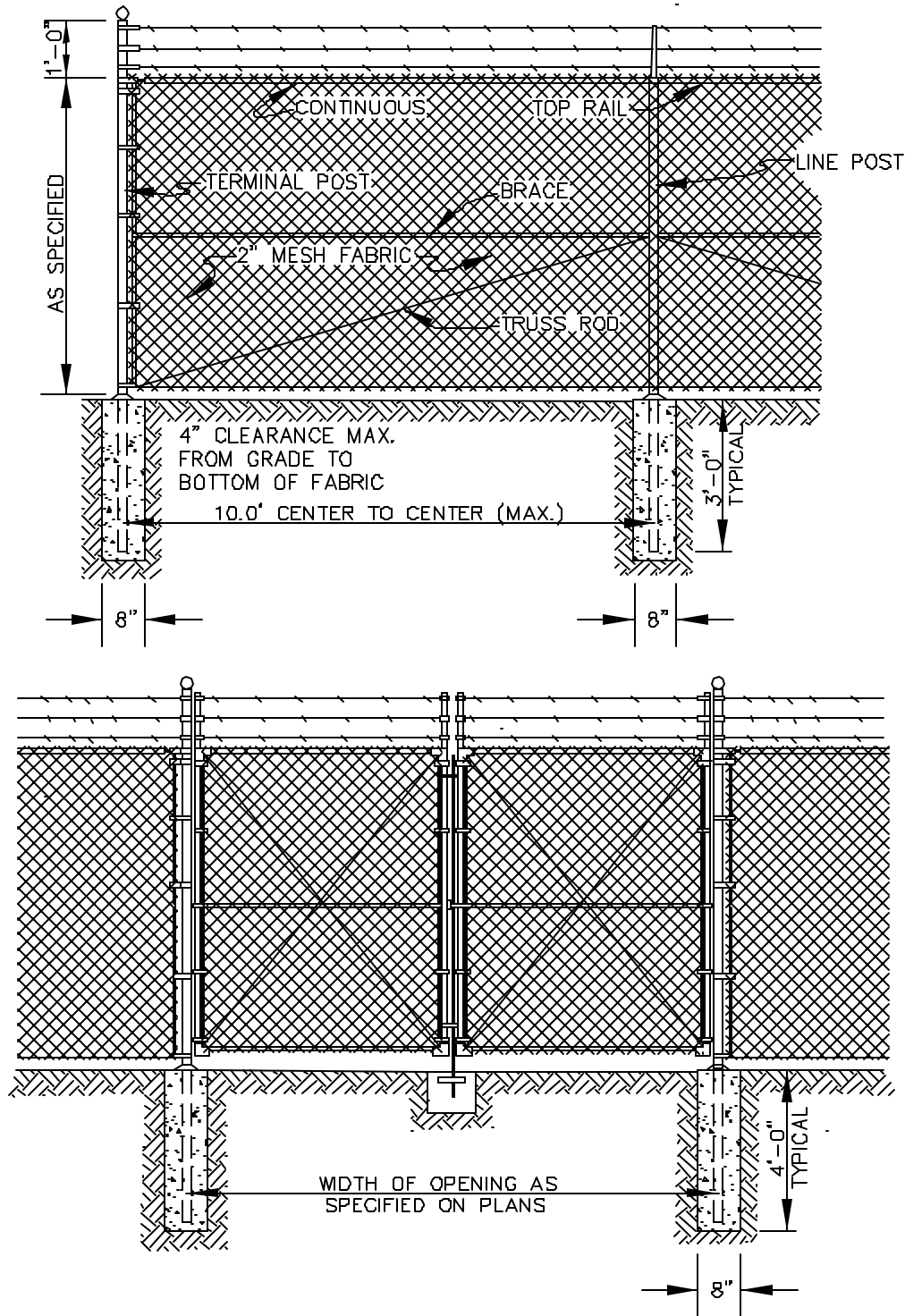

NOTES:

1. GAUGE OF FABRIC TO BE SPECIFIED ON PLANS.
2. SIZE OF TUBULAR STEEL FOR GATE FRAMES IS SPECIFIED IN STANDARD CONSTRUCTION SPECIFICATION FOR CHAIN LINK FENCES.



SCALE:
NTS
APPROVED:
RAR
REVISED:
11/29/02

FENCE DETAILS

SECTION #
75.06

DETAIL #
75-4

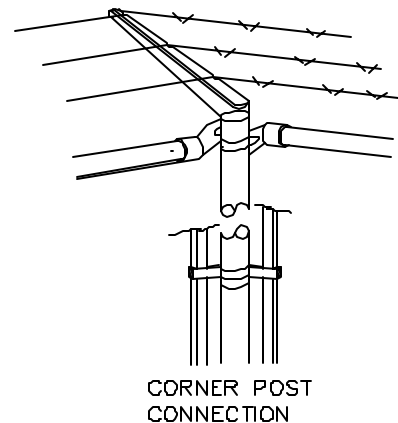
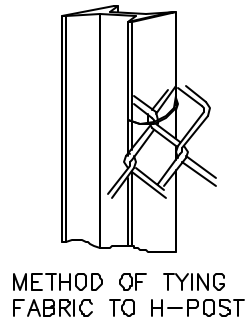
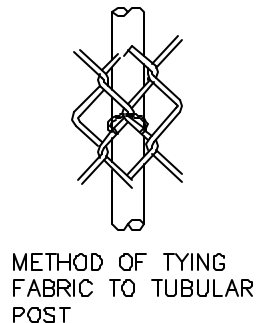
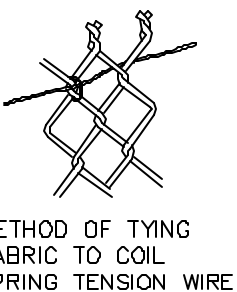
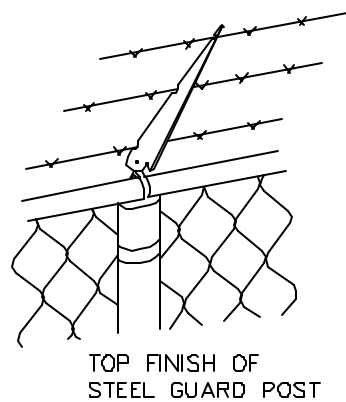
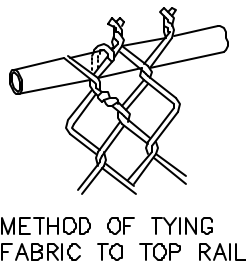
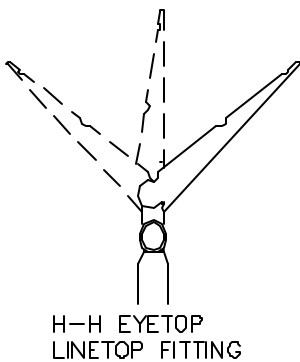
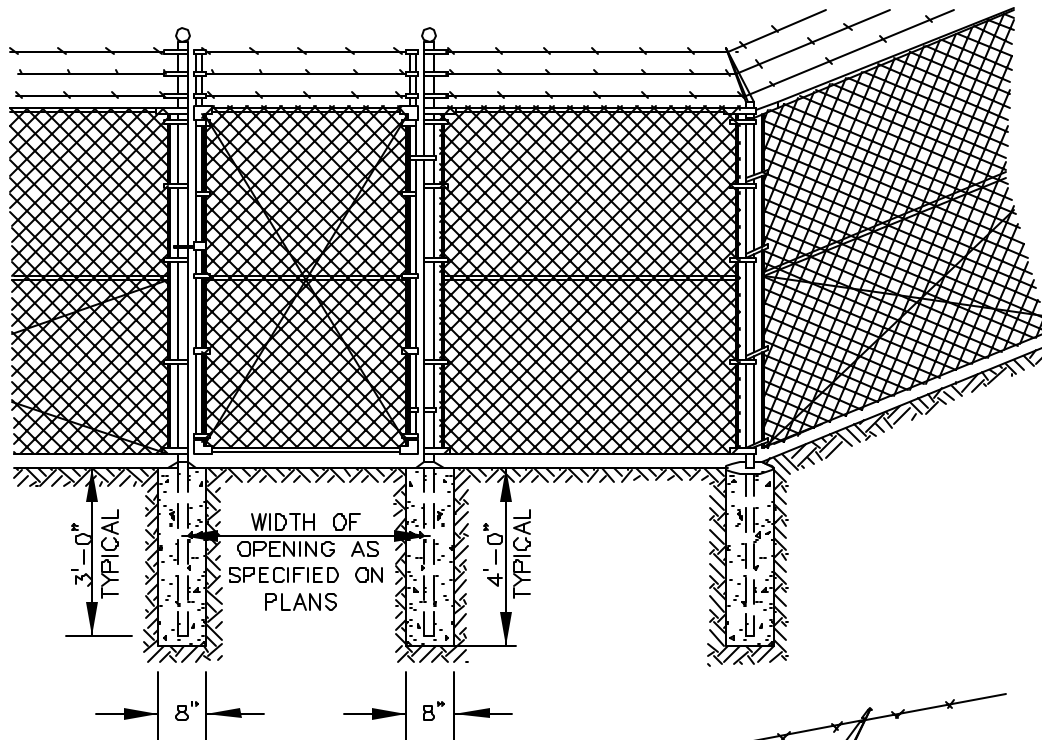

NOTE:

1. SIZE OF TUBULAR STEEL FOR GATES IS SPECIFIED IN STANDARD CONSTRUCTION SPECIFICATIONS FOR CHAIN LINK FENCES.



SCALE:
NTS
APPROVED:
RAR
REVISED:
11/29/02

FENCE DETAILS

SECTION #
75.06

DETAIL #
75-5

ASPHALT CONCRETE WEARING COURSE, 3" MIN. COMPACTED DEPTH IN TWO EQUAL LIFTS

CONDUIT $\varnothing + 2"$

PORTLAND CEMENT CONCRETE SIDEWALK

SAW CUT EXIST. ASPHALT

SAW CUT EXIST. WALK

EXIST. ASPHALT

30" MIN.

30" MIN.

BASE COURSE MATERIAL

BASE COURSE MATERIAL

RMC

RMC



SCALE:
NTS
APPROVED:
RAR
REVISED:
11/29/02

SAW CUT TRENCH

SECTION#
80.02
DETAIL #
80-1